

Documentation | EN

# EP3204-0002 and EP3314-0002

EtherCAT Box Modules for Pt100 (RTD) and for thermocouples





# Table of contents

<b>1</b>	<b>Foreword</b> .....	<b>5</b>
1.1	Notes on the documentation .....	5
1.2	Safety instructions .....	6
1.3	Documentation issue status .....	7
<b>2</b>	<b>Module overview</b> .....	<b>9</b>
<b>3</b>	<b>EP3204-0002</b> .....	<b>10</b>
3.1	Introduction .....	10
3.2	Technical data .....	11
3.3	Process image .....	13
3.4	Scope of supply.....	13
<b>4</b>	<b>EP3314-0002</b> .....	<b>14</b>
4.1	Introduction .....	14
4.2	Technical data .....	15
4.2.1	Thermocouple specifications.....	17
4.3	Process image .....	29
4.4	Scope of supply.....	30
4.5	Basics of thermocouple technology .....	31
<b>5</b>	<b>Mounting and connection</b> .....	<b>32</b>
5.1	Mounting .....	32
5.1.1	Dimensions .....	32
5.1.2	Fixing.....	33
5.1.3	Tightening torques for plug connectors.....	33
5.2	Connection .....	34
5.2.1	Supply voltages.....	34
5.2.2	EtherCAT .....	37
5.2.3	Signal connection.....	39
5.3	UL Requirements .....	44
5.4	ATEX notes .....	45
5.4.1	ATEX - Special conditions.....	45
5.4.2	BG2000 - EtherCAT Box protection enclosures.....	46
5.4.3	ATEX Documentation.....	47
5.5	Disposal .....	48
<b>6</b>	<b>Commissioning/Configuration</b> .....	<b>49</b>
6.1	Integrating into a TwinCAT project.....	49
6.2	EP3204 – Data stream and calculation of the process data .....	49
6.2.1	Vendor calibration .....	49
6.2.2	User calibration and linearization .....	53
6.2.3	Scaling, limits and formatting .....	54
6.2.4	Summary.....	55
6.2.5	Two-point user calibration .....	56
6.3	EP3204 - object overview .....	58
6.4	EP3204 - object description and parameterization .....	64
6.4.1	Objects to be parameterized during commissioning .....	64

6.4.2	Objects for regular operation.....	69
6.4.3	Standard objects (0x1000-0x1FFF) .....	70
6.4.4	Profile-specific objects (0x6000-0xFFFF) .....	73
6.5	EP3314 - Settings .....	78
6.5.1	Cold junction compensation .....	78
6.5.2	Presentation, index 0x80n0:02.....	80
6.5.3	Siemens bits, index 0x80n0:05 .....	82
6.5.4	Underrange, Overrange .....	82
6.5.5	Filter .....	82
6.5.6	Limit 1 and Limit 2 .....	82
6.5.7	Calibration .....	83
6.6	EP3314 - object overview .....	85
6.7	EP3314 - object description and parameterization .....	92
6.7.1	Objects to be parameterized during commissioning .....	92
6.7.2	Objects for regular operation.....	98
6.7.3	Standard objects (0x1000-0x1FFF) .....	98
6.7.4	Profile-specific objects (0x6000-0xFFFF) .....	104
6.8	Restoring the delivery state.....	109
6.9	Decommissioning .....	110
<b>7</b>	<b>Appendix.....</b>	<b>111</b>
7.1	General operating conditions .....	111
7.2	Accessories .....	112
7.3	Version identification of EtherCAT devices .....	113
7.3.1	General notes on marking.....	113
7.3.2	Version identification of IP67 modules .....	114
7.3.3	Beckhoff Identification Code (BIC) .....	115
7.3.4	Electronic access to the BIC (eBIC).....	117
7.4	Support and Service.....	119

# 1 Foreword

## 1.1 Notes on the documentation

### Intended audience

This description is only intended for the use of trained specialists in control and automation engineering who are familiar with the applicable national standards.

It is essential that the documentation and the following notes and explanations are followed when installing and commissioning these components.

The qualified personnel is obliged to always use the currently valid documentation.

The responsible staff must ensure that the application or use of the products described satisfy all the requirements for safety, including all the relevant laws, regulations, guidelines and standards.

### Disclaimer

The documentation has been prepared with care. The products described are, however, constantly under development.

We reserve the right to revise and change the documentation at any time and without prior announcement.

No claims for the modification of products that have already been supplied may be made on the basis of the data, diagrams and descriptions in this documentation.

### Trademarks

Beckhoff®, TwinCAT®, TwinCAT/BSD®, TC/BSD®, EtherCAT®, EtherCAT G®, EtherCAT G10®, EtherCAT P®, Safety over EtherCAT®, TwinSAFE®, XFC®, XTS® and XPlanar® are registered trademarks of and licensed by Beckhoff Automation GmbH. Other designations used in this publication may be trademarks whose use by third parties for their own purposes could violate the rights of the owners.

### Patent Pending

The EtherCAT Technology is covered, including but not limited to the following patent applications and patents: EP1590927, EP1789857, EP1456722, EP2137893, DE102015105702 with corresponding applications or registrations in various other countries.



EtherCAT® is registered trademark and patented technology, licensed by Beckhoff Automation GmbH, Germany.

### Copyright

© Beckhoff Automation GmbH & Co. KG, Germany.

The reproduction, distribution and utilization of this document as well as the communication of its contents to others without express authorization are prohibited.

Offenders will be held liable for the payment of damages. All rights reserved in the event of the grant of a patent, utility model or design.

## 1.2 Safety instructions

### Safety regulations

Please note the following safety instructions and explanations!  
Product-specific safety instructions can be found on following pages or in the areas mounting, wiring, commissioning etc.

### Exclusion of liability

All the components are supplied in particular hardware and software configurations appropriate for the application. Modifications to hardware or software configurations other than those described in the documentation are not permitted, and nullify the liability of Beckhoff Automation GmbH & Co. KG.

### Personnel qualification

This description is only intended for trained specialists in control, automation and drive engineering who are familiar with the applicable national standards.

### Signal words

The signal words used in the documentation are classified below. In order to prevent injury and damage to persons and property, read and follow the safety and warning notices.

#### Personal injury warnings

**⚠ DANGER**

Hazard with high risk of death or serious injury.

**⚠ WARNING**

Hazard with medium risk of death or serious injury.

**⚠ CAUTION**

There is a low-risk hazard that could result in medium or minor injury.

#### Warning of damage to property or environment

**NOTICE**

The environment, equipment, or data may be damaged.

#### Information on handling the product



This information includes, for example:  
recommendations for action, assistance or further information on the product.

### 1.3 Documentation issue status

Version	Comment
2.7	<ul style="list-style-type: none"> <li>Chapter "Thermocouple specifications" added to the technical data of EP3314-0002.</li> </ul>
2.6	<ul style="list-style-type: none"> <li>Chapter "Supply voltages" updated</li> </ul>
2.5	<ul style="list-style-type: none"> <li>Thermocouple connection updated</li> <li>Activation of cold junction compensation added</li> <li>Dimensions updated</li> <li>UL requirements updated</li> </ul>
2.4	<ul style="list-style-type: none"> <li>Terminology update</li> <li>Structure update</li> </ul>
2.3	<ul style="list-style-type: none"> <li>Chapter „EP3314 – Settings“ added</li> <li>Chapter “Basics of thermocouple technology” updated</li> <li>Structure update</li> </ul>
2.2	<ul style="list-style-type: none"> <li>Object descriptions corrected</li> <li>Structure update</li> </ul>
2.1.0	<ul style="list-style-type: none"> <li>Chapter <i>EP3204 – Data stream and calculation of the process data</i> added</li> <li>Update of chapter <i>Mounting and connection</i></li> <li>Correction technical data in chapter <i>Power cables</i></li> <li>Structural update</li> </ul>
2.0.1	<ul style="list-style-type: none"> <li>EP3204-0002 - Technical data updated</li> </ul>
2.0.0	<ul style="list-style-type: none"> <li>Migration</li> <li>Structure update</li> </ul>
1.2.0	<ul style="list-style-type: none"> <li>EP3204 - object description and parameterization updated</li> <li>EP3314 - object description and parameterization updated</li> <li>Foreword updated</li> <li>Technical data updated</li> </ul>
1.1.0	<ul style="list-style-type: none"> <li>Power Connection updated</li> </ul>
1.0.0	<ul style="list-style-type: none"> <li>ATEX notes added</li> <li>Technical data updated</li> <li>Extended temperature range for activated modules documented</li> <li>Overview of EtherCAT cables extended</li> <li>Description of the power connection updated</li> <li>Description of the status LEDs for the power supply added</li> </ul>
0.6	<ul style="list-style-type: none"> <li>Object descriptions corrected</li> </ul>
0.5	<ul style="list-style-type: none"> <li>First preliminary version</li> </ul>

**Firmware and hardware versions**

This documentation refers to the firmware and hardware version that was applicable at the time the documentation was written.

The module features are continuously improved and developed further. Modules having earlier production statuses cannot have the same properties as modules with the latest status. However, existing properties are retained and are not changed, so that older modules can always be replaced with new ones.

The firmware and hardware version (delivery state) can be found in the batch number (D-number) printed on the side of the EtherCAT Box.

**Syntax of the batch number (D-number)**

D: WW YY FF HH

WW - week of production (calendar week)

YY - year of production

FF - firmware version

HH - hardware version

Example with D no. 29 10 02 01:

29 - week of production 29

10 - year of production 2010

02 - firmware version 02

01 - hardware version 01

Further information on this topic: [Version identification of EtherCAT devices \[► 113\]](#).



## 2 Module overview

### Analog input modules, 24 VDC

Module	Number of inputs	Signal connection	Comment
<a href="#">EP3204-0002 [▶_10]</a>	4	M12	Pt100 (RTD)
<a href="#">EP3314-0002 [▶_14]</a>	4	M12	Thermocouples

## 3 EP3204-0002

### 3.1 Introduction

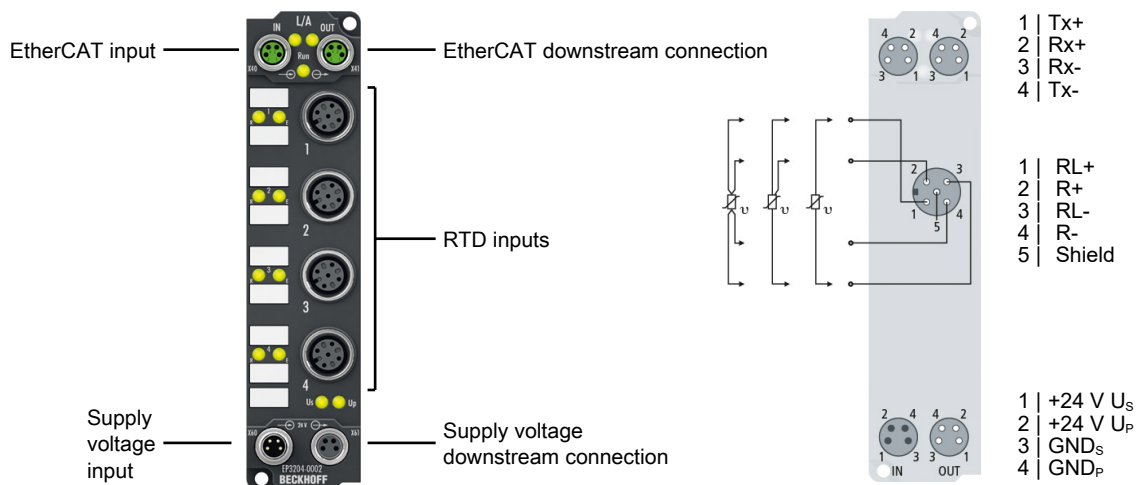

#### EtherCAT Box with four analog inputs for Pt100 (RTD)

The EP3204 EtherCAT Box with analog inputs enables direct connection of resistance sensors. The module circuit can operate sensors with 2-, 3- and 4-wire technology. Linearisation over the full temperature range is realized with the aid of a microprocessor. The temperature range can be selected freely. The module can also be used for simple resistance measurement, with the output in ohms. The module's standard settings are: Resolution 0.1°C in the temperature range of Pt100 sensors in 4-wire connection. Sensor malfunctions such as broken wires are indicated by error LEDs.

The module is quite versatile, but the default values are selected in such a way that in most cases it is not necessary to perform configuration. The input filter and associated conversion times can be set within a wide range, and several data output formats may be chosen. The inputs can, if required, be scaled differently, and automatic limit monitoring is also available. EtherCAT is used for parameterization purposes.

#### Quick links

[Technical data \[▶ 11\]](#)

[Process image \[▶ 13\]](#)

[Signal connections \[▶ 39\]](#)

[Calibration and scaling \[▶ 49\]](#)

## 3.2 Technical data

All values are typical values over the entire temperature range, unless stated otherwise.

EtherCAT	
Connection	2 x M8 socket, 4-pin, A-coded, shielded
Electrical isolation	500 V

Supply voltages	
Connection	Input: M8 connector, 4-pin, A-coded Downstream connection: M8 socket, 4-pin, A-coded
$U_S$ nominal voltage	24 V <sub>DC</sub> (-15 % / +20 %)
$U_S$ sum current: $I_{S,sum}$	max. 4 A
Current consumption from $U_S$	120 mA
Rated voltage $U_P$	24 V <sub>DC</sub> (-15 % / +20 %)
$U_P$ sum current: $I_{P,sum}$	max. 4 A
Current consumption from $U_P$	None. $U_P$ is only forwarded.

RTD inputs	
Number	4
Connector	4x M12 socket, 5-pin, A-coded
Cable length	max. 30 m between box and sensor
Sensor types	<ul style="list-style-type: none"> <li>Platinum RTD: Pt100, Pt200, Pt500, Pt1000</li> <li>Nickel RTD: Ni100, Ni120, Ni1000</li> <li>Resistance/potentiometer up to 4095 Ω</li> </ul>
Connection technology	<ul style="list-style-type: none"> <li>Two-wire technique</li> <li>Three-wire technique</li> <li>Four-wire technique</li> </ul>
Electrical isolation	The measuring channels have a common isolated ground potential.
Measuring current RL+, RL-	max. 0.5 mA, load-dependent
Measuring range	Platinum RTD: -200...+850 °C Nickel RTD: -60...+250 °C (Ni120: -60...+320 °C) Resistance: 0...4095 Ω
Measuring error	max. ±0.5 K (Pt sensors in 4-wire technique)
Digital resolution	16 bit
Value of an LSB	Temperature measurement: Standard: 0.1 °C High-precision: 0.01 °C  Resistance measurement: Measuring range 1023 Ω: 1/64 Ω Measuring range 4095 Ω: 1/16 Ω
Filter	Digital filter. Cut-off frequency (parameterizable): 5 Hz .. 30 kHz.
Conversion time	2...800 ms, depending on the parameterization. Default: approx. 85 ms
Diagnosis	<ul style="list-style-type: none"> <li>Wire break detection</li> <li>Limit value monitoring</li> </ul>

Housing data	
Dimensions W x H x D	30 mm x 126 mm x 26.5 mm (without connectors)
Weight	approx. 165 g
Installation position	variable
Material	PA6 (polyamide)

Environmental conditions	
Ambient temperature during operation	-25 ... +60 °C -25 ... +55 °C according to cURus 0 ... +55 °C according to ATEX
Ambient temperature during storage	-40 ... +85 °C
Vibration resistance, shock resistance	conforms to EN 60068-2-6 / EN 60068-2-27 Additional tests [► 12]
EMC immunity / emission	conforms to EN 61000-6-2 / EN 61000-6-4
Protection rating	IP65, IP66, IP67 (according to EN 60529)

Approvals / markings	
Approvals / markings *)	ATEX [► 45], CE, cURus [► 44]

\*) Real applicable approvals/markings see type plate on the side (product marking).

### Additional tests

The devices have undergone the following additional tests:

Test	Explanation
Vibration	10 frequency sweeps in 3 axes
	5 Hz < f < 60 Hz displacement 0.35 mm, constant amplitude
	60.1 Hz < f < 500 Hz acceleration 5 g, constant amplitude
Shocks	1000 shocks in each direction, in 3 axes
	35 g, 11 ms

### 3.3 Process image

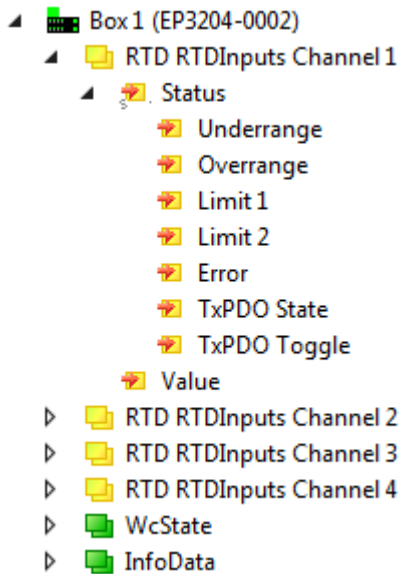

Fig. 1: RTD RTDInputs Channel 1

The data for the first analog channel can be found under **RTD RTDInputs Channel 1**.

#### AI Standard Channel 2 to 4

The data of analog channels 2 to 4 have the same structure as those of the 1<sup>st</sup> channel.

### 3.4 Scope of supply

Make sure that the following components are included in the scope of delivery:

- 1x EtherCAT Box EP3204-0002
- 1x protective cap for supply voltage input, M8, transparent (pre-assembled)
- 1x protective cap for supply voltage output, M8, black (pre-assembled)
- 2x protective cap for EtherCAT socket, M8, green (pre-assembled)
- 10x labels, blank (1 strip of 10)

---

#### ● **Pre-assembled protective caps do not ensure IP67 protection**

**i** Protective caps are pre-assembled at the factory to protect connectors during transport. They may not be tight enough to ensure IP67 protection.

Ensure that the protective caps are correctly seated to ensure IP67 protection.

---

## 4 EP3314-0002

### 4.1 Introduction

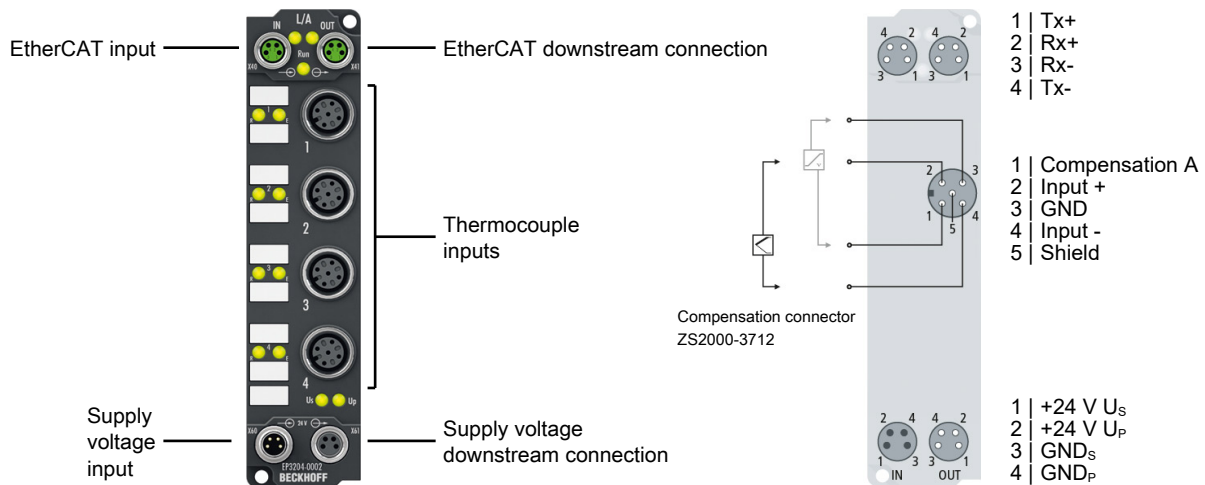

#### EtherCAT Box with four analog inputs for thermocouples

The EP3314 EtherCAT Box with analog inputs enables direct connection of four thermocouples. The module circuit can operate thermocouple sensors in a 2-wire configuration. Linearisation over the full temperature range is realized with the aid of a microprocessor. The temperature range can be selected freely. The error LEDs indicate a broken wire. Compensation for the cold junction is made through a temperature measurement in the connecting plugs. This means that standard extension leads can be connected. The EP3314 also enables millivolt measurement.

The module is quite versatile, but the default values are selected in such a way that in most cases it is not necessary to perform configuration. The input filter and associated conversion times can be set within a wide range, and several data output formats may be chosen. The inputs can, if required, be scaled differently, and automatic limit monitoring is also available. EtherCAT is used for parameterization purposes. The parameters are stored in the module. For temperature compensation a Pt1000 element is required. Beckhoff offers a plug connector with temperature compensation (ZS2000-3712).

#### Quick links

[Technical data](#) [▶ 15]

[Process image](#) [▶ 29]

[Signal connection](#) [▶ 40]

[Settings](#) [▶ 78]

## 4.2 Technical data

All values are typical values over the entire temperature range, unless stated otherwise.

EtherCAT	
Connection	2 x M8 socket, 4-pin, A-coded, shielded
Electrical isolation	500 V

Supply voltages	
Connection	Input: M8 connector, 4-pin, A-coded Downstream connection: M8 socket, 4-pin, A-coded
$U_S$ nominal voltage	24 V <sub>DC</sub> (-15 % / +20 %)
$U_S$ sum current: $I_{S,sum}$	max. 4 A
Current consumption from $U_S$	120 mA
Rated voltage $U_P$	24 V <sub>DC</sub> (-15 % / +20 %)
$U_P$ sum current: $I_{P,sum}$	max. 4 A
Current consumption from $U_P$	None. $U_P$ is only forwarded.

Thermocouple inputs	
Number	4
Connector	4x M12 socket, 5-pin, A-coded
Cable length	max. 30 m between box and thermocouple
Sensor types	<ul style="list-style-type: none"> <li>• Thermocouples</li> <li>• Sensors with voltage output up to <math>\pm 75</math> mV</li> </ul>
Electrical isolation	The measuring channels have a common isolated ground potential.
Measuring ranges	Thermocouples: depending on the thermocouple type <a href="#">[► 16]</a> . Voltage measurement: $\pm 30$ mV, $\pm 60$ mV, $\pm 75$ mV
Measurement uncertainty	see chapter <a href="#">Thermocouple specifications [► 17]</a> .
Digital resolution	16 bit
Value of an LSB	Adjustable for thermocouple measurement: <ul style="list-style-type: none"> <li>• 0.1 °C (factory setting)</li> <li>• 0.01 °C</li> </ul> For voltage measurement: <ul style="list-style-type: none"> <li>• Measuring range 30 mV: 1 <math>\mu</math>V</li> <li>• Measuring range 60 mV: 2 <math>\mu</math>V</li> <li>• Measuring range 75 mV: 4 <math>\mu</math>V</li> </ul>
Filter	Digital filter. Filter frequency adjustable from 5 Hz ... 30 kHz
Conversion time	approx. 2.5 s to 20 ms, depending on configuration and filter setting. Default: approx. 250 ms
Diagnosis	<ul style="list-style-type: none"> <li>• Wire break detection</li> <li>• Limit value monitoring</li> </ul>

<sup>1)</sup> This value corresponds to the current carrying capacity of the connections for the supply voltages.

Housing data	
Dimensions W x H x D	30 mm x 126 mm x 26.5 mm (without connectors)
Weight	approx. 165 g
Installation position	variable
Material	PA6 (polyamide)

Environmental conditions	
Ambient temperature during operation	-25 ... +60 °C -25 ... +55 °C according to cURus 0 ... +55 °C according to ATEX
Ambient temperature during storage	-40 ... +85 °C
Vibration resistance, shock resistance	conforms to EN 60068-2-6 / EN 60068-2-27 Additional tests [► 16]
EMC immunity / emission	conforms to EN 61000-6-2 / EN 61000-6-4
Protection rating	IP65, IP66, IP67 (according to EN 60529)

Approvals / markings	
Approvals / markings *)	ATEX [► 45], CE, cURus [► 44]

\*) Real applicable approvals/markings see type plate on the side (product marking).

### Additional tests

The devices have undergone the following additional tests:

Test	Explanation
Vibration	10 frequency sweeps in 3 axes
	5 Hz < f < 60 Hz displacement 0.35 mm, constant amplitude
	60.1 Hz < f < 500 Hz acceleration 5 g, constant amplitude
Shocks	1000 shocks in each direction, in 3 axes
	35 g, 11 ms

### Overview of suitable thermocouples

The following thermocouple types are suitable for temperature measurement:

Type (conforms to EN60584-1)	Element	Implemented temperature range	Color coding (sheath - positive pole - negative pole)
B	Pt30%Rh-Pt6Rh	200 °C to 1820 °C	grey - grey - white
C *	W5%Re-W25%Re	0 °C to 2320 °C	n.d.
E	NiCr-CuNi	-100°C to 1000°C	violet - violet - white
J	Fe-CuNi	-100°C to 1200°C	black - black - white
K	NiCr-Ni	-200°C to 1372°C	green - green - white
L **	Fe-CuNi	0 °C to 900 °C	blue - red - blue
N	NiCrSi-NiSi	-100°C to 1300°C	pink - pink - white
R	Pt13%Rh-Pt	-50°C to 1767°C	orange - orange - white
S	Pt10%Rh-Pt	-50°C to 1760°C	orange - orange - white
T	Cu-CuNi	-200°C to 400°C	brown - brown - white
U **	Cu-CuNi	0 °C to 600 °C	brown - red - brown

\*not standardized according to EN60584-1

\*\* according to DIN 43710



## 4.2.1 Thermocouple specifications

In the measuring range of a specified thermocouple type, a measured voltage is converted internally into a temperature according to the set transformation. Since the channel measures a voltage internally, the corresponding measuring error in the voltage measuring range must be used.

The thermocouple measurement specifications shown in the following tables only apply if connectors of type ZS2000-3712 are used for cold junction compensation. See chapter [Accessories](#) [► 112].

The box can also be used with an external cold junction, if required. The uncertainties must then be determined for the external cold junction on the application side. The temperature value of the external cold junction must then be communicated to the box via the process data for its own calculation. The effect on the measurement of the thermocouples must then be calculated on the system side.

The specifications for the internal cold junction and the measuring range given here apply only if the following times are adhered to for thermal stabilization at constant ambient temperature:

- after switching on: 60 min
- after changing wiring/connectors: 15 min

### Specification of the internal cold junction measurement

Measurement mode		Cold junction
Basic accuracy: Measurement deviation at 23 °C, with averaging		< ±2.5 °C
Temperature coefficient	TC	< 25 mK/K

**Specification - thermocouple type B**

Temperature measurement thermocouple		Type B
Electrical measuring range used		± 75 mV
Measuring range, technically usable		+200 °C ≈ 0.178 mV ... +1820 °C ≈ 13.820 mV
Measuring range, end value (full scale value)		+1820 °C
Measuring range, recommended		+750 °C ... +1800 °C
PDO LSB		0.1 / 0.01 °C/digit, depending on PDO setting Note: internally, 16 bits are used for the calculation up to the FSV; depending on the set thermocouple, therefore, jumps in value >0.01 °C occur with "resolution 0.01 °C"; e.g. type B: approx. 0.05 °C
Uncertainty in the recommended measuring range, with averaging	@ 23 °C ambient temperature	± 3.7 K ≈ ± 0.20 % <sub>FSV</sub>
	@ 55 °C ambient temperature	± 5.1 K ≈ ± 0.28 % <sub>FSV</sub>
Temperature coefficient (Change in the measured value in relation to the change in the ambient temperature of the terminal)		<i>Since the value is highly dependent on the sensor temperature, as can be seen in the specification plot shown below, it must basically be derived from the specification plot. For better approximation, the measurement uncertainty at T<sub>amb</sub> = 39 °C as the middle point between 23 °C and 55 °C is also shown informatively in order to illustrate the non-linear curve.</i>

Measurement uncertainty for thermocouple type B:

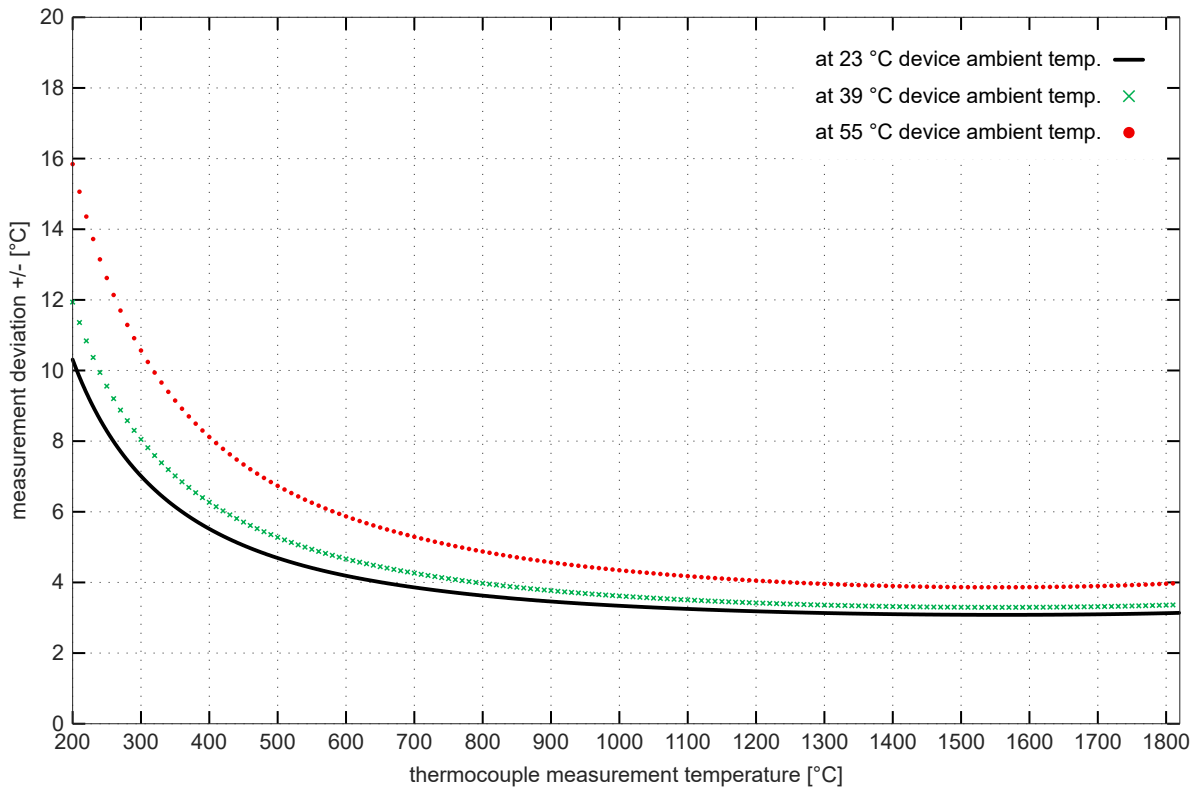

Specification - thermocouple type C

Temperature measurement thermocouple		Type C
Electrical measuring range used		± 75 mV
Measuring range, technically usable		0 °C ≈ 0 mV ... +2320 °C ≈ 37.107 mV
Measuring range, end value (full scale value)		+2320 °C
Measuring range, recommended		0 °C ... +2000 °C
PDO LSB		0.1 / 0.01 °C/digit, depending on PDO setting Note: internally, 16 bits are used for the calculation up to the FSV; depending on the set thermocouple, therefore, jumps in value >0.01 °C occur with "resolution 0.01 °C"; e.g. type C: approx. 0.07 °C
Uncertainty in the recommended measuring range, with averaging	@ 23 °C ambient temperature	± 3.4 K ≈ ± 0.15 % <sub>FSV</sub>
	@ 55 °C ambient temperature	± 4.6 K ≈ ± 0.20 % <sub>FSV</sub>
Temperature coefficient (Change in the measured value in relation to the change in the ambient temperature of the terminal)		<i>Since the value is highly dependent on the sensor temperature, as can be seen in the specification plot shown below, it must basically be derived from the specification plot. For better approximation, the measurement uncertainty at T<sub>amb</sub> = 39 °C as the middle point between 23 °C and 55 °C is also shown informatively in order to illustrate the non-linear curve.</i>

Measurement uncertainty for thermocouple type C:

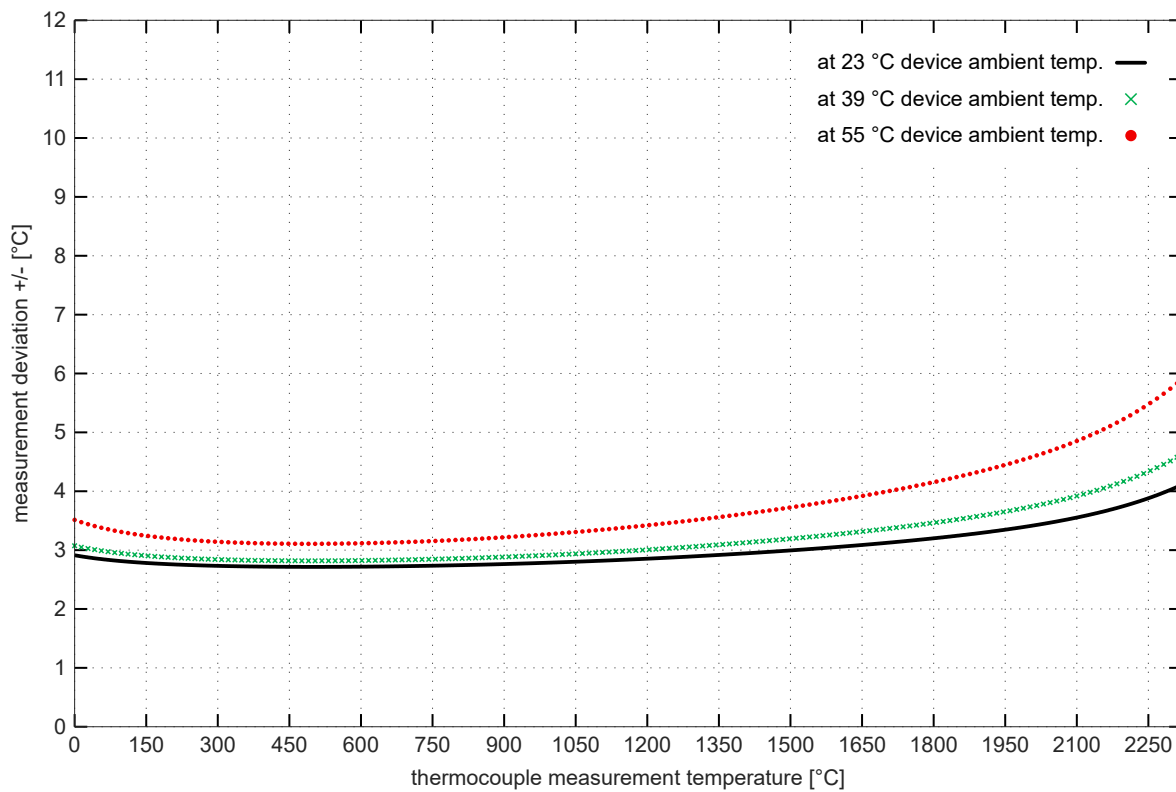

**Specification - thermocouple type E**

Temperature measurement thermocouple		Type E
Electrical measuring range used		± 75 mV
Measuring range, technically usable		-100 °C ≈ -5.237 mV ... +1000 °C ≈ 76.372 mV
Measuring range, end value (full scale value)		+1000 °C
Measuring range, recommended		-100 °C ... +1000 °C
PDO LSB		0.1 / 0.01 °C/digit, depending on PDO setting Note: internally, 16 bits are used for the calculation up to the FSV; depending on the set thermocouple, therefore, jumps in value >0.01 °C occur with "resolution 0.01 °C"; e.g. type E: approx. 0.03 °C
Uncertainty in the recommended measuring range, with averaging	@ 23 °C ambient temperature	± 2.6 K ≈ ± 0.26 % <sub>FSV</sub>
	@ 55 °C ambient temperature	± 2.8 K ≈ ± 0.28 % <sub>FSV</sub>
Temperature coefficient (Change in the measured value in relation to the change in the ambient temperature of the terminal)		<i>Since the value is highly dependent on the sensor temperature, as can be seen in the specification plot shown below, it must basically be derived from the specification plot. For better approximation, the measurement uncertainty at T<sub>amb</sub> = 39 °C as the middle point between 23 °C and 55 °C is also shown informatively in order to illustrate the non-linear curve.</i>

Measurement uncertainty for thermocouple type E:

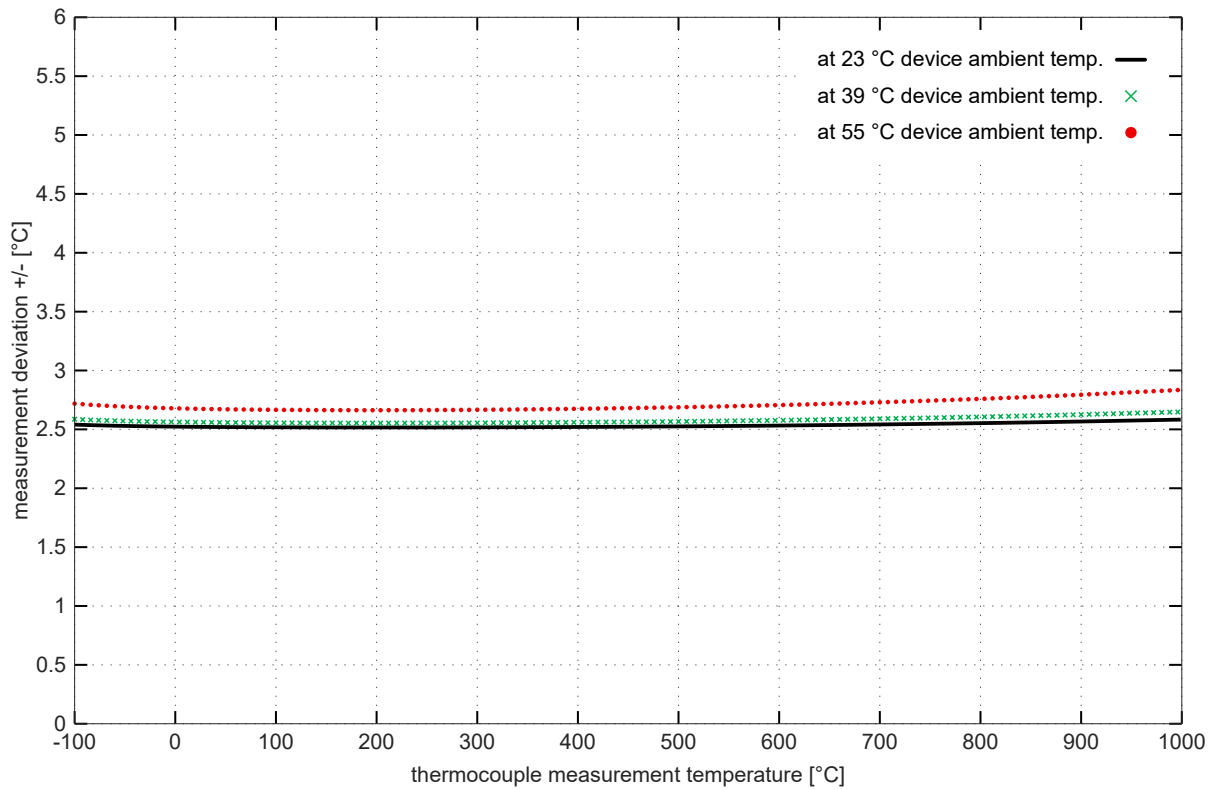

Specification - thermocouple type J

Temperature measurement thermocouple		Type J
Electrical measuring range used		± 75 mV
Measuring range, technically usable		-100 °C ≈ -4.632 mV ... +1200 °C ≈ 69.553 mV
Measuring range, end value (full scale value)		+1200 °C
Measuring range, recommended		-100 °C ... +1200 °C
PDO LSB		0.1 / 0.01 °C/digit, depending on PDO setting Note: internally, 16 bits are used for the calculation up to the FSV; depending on the set thermocouple, therefore, jumps in value >0.01 °C occur with "resolution 0.01 °C"; e.g. type J: approx. 0.04 °C
Uncertainty in the recommended measuring range, with averaging	@ 23 °C ambient temperature	± 2.6 K ≈ ± 0.22 % <sub>FSV</sub>
	@ 55 °C ambient temperature	± 2.9 K ≈ ± 0.24 % <sub>FSV</sub>
Temperature coefficient (Change in the measured value in relation to the change in the ambient temperature of the terminal)		<i>Since the value is highly dependent on the sensor temperature, as can be seen in the specification plot shown below, it must basically be derived from the specification plot. For better approximation, the measurement uncertainty at T<sub>amb</sub> = 39 °C as the middle point between 23 °C and 55 °C is also shown informatively in order to illustrate the non-linear curve.</i>

Measurement uncertainty for thermocouple type J:

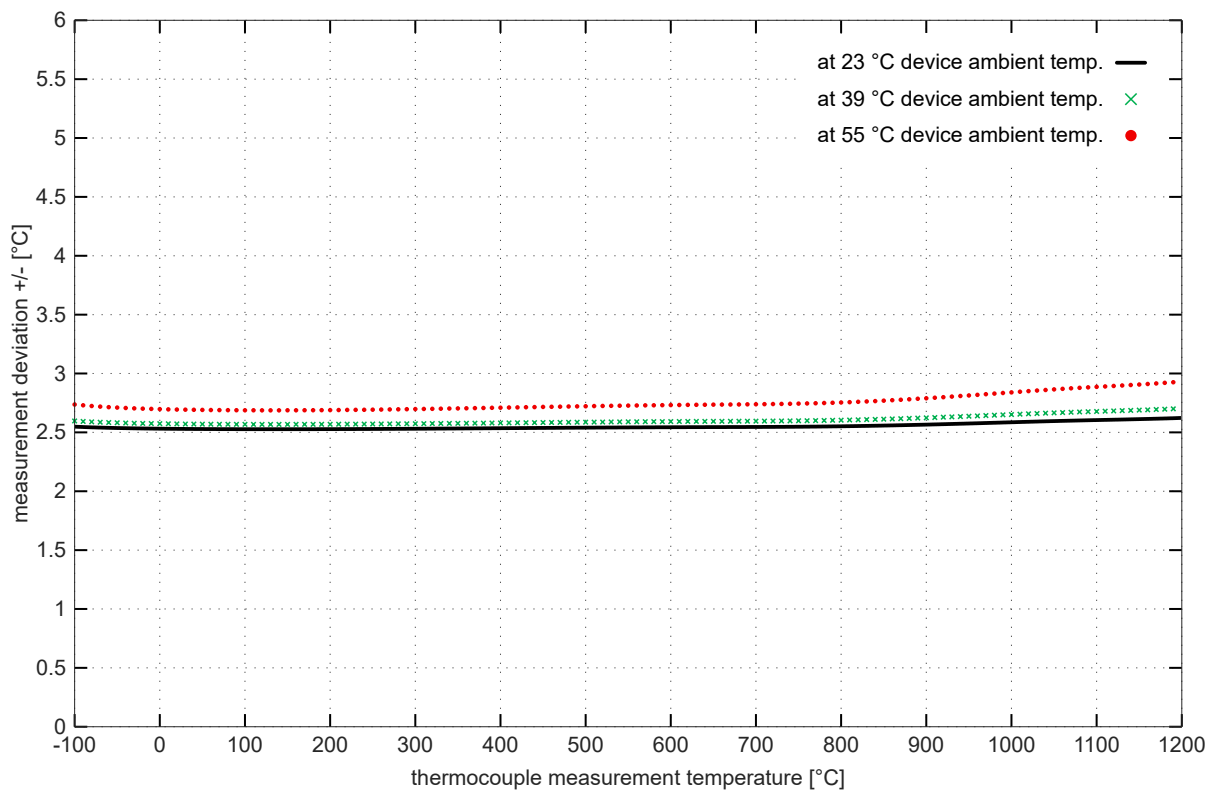

**Specification - thermocouple type K**

Temperature measurement thermocouple		Type K
Electrical measuring range used		± 75 mV
Measuring range, technically usable		-200 °C ≈ -5.891 mV ... +1372 °C ≈ 54.886 mV
Measuring range, end value (full scale value)		+1372 °C
Measuring range, recommended		-100 °C ... +1200 °C
PDO LSB		0.1 / 0.01 °C/digit, depending on PDO setting Note: internally, 16 bits are used for the calculation up to the FSV; depending on the set thermocouple, therefore, jumps in value >0.01 °C occur with "resolution 0.01 °C"; e.g. type K: approx. 0.04 °C
Uncertainty in the recommended measuring range, with averaging	@ 23 °C ambient temperature	± 2.7 K ≈ ± 0.20 % <sub>FSV</sub>
	@ 55 °C ambient temperature	± 3.1 K ≈ ± 0.23 % <sub>FSV</sub>
Temperature coefficient (Change in the measured value in relation to the change in the ambient temperature of the terminal)		<i>Since the value is highly dependent on the sensor temperature, as can be seen in the specification plot shown below, it must basically be derived from the specification plot. For better approximation, the measurement uncertainty at T<sub>amb</sub> = 39 °C as the middle point between 23 °C and 55 °C is also shown informatively in order to illustrate the non-linear curve.</i>

Measurement uncertainty for thermocouple type K:

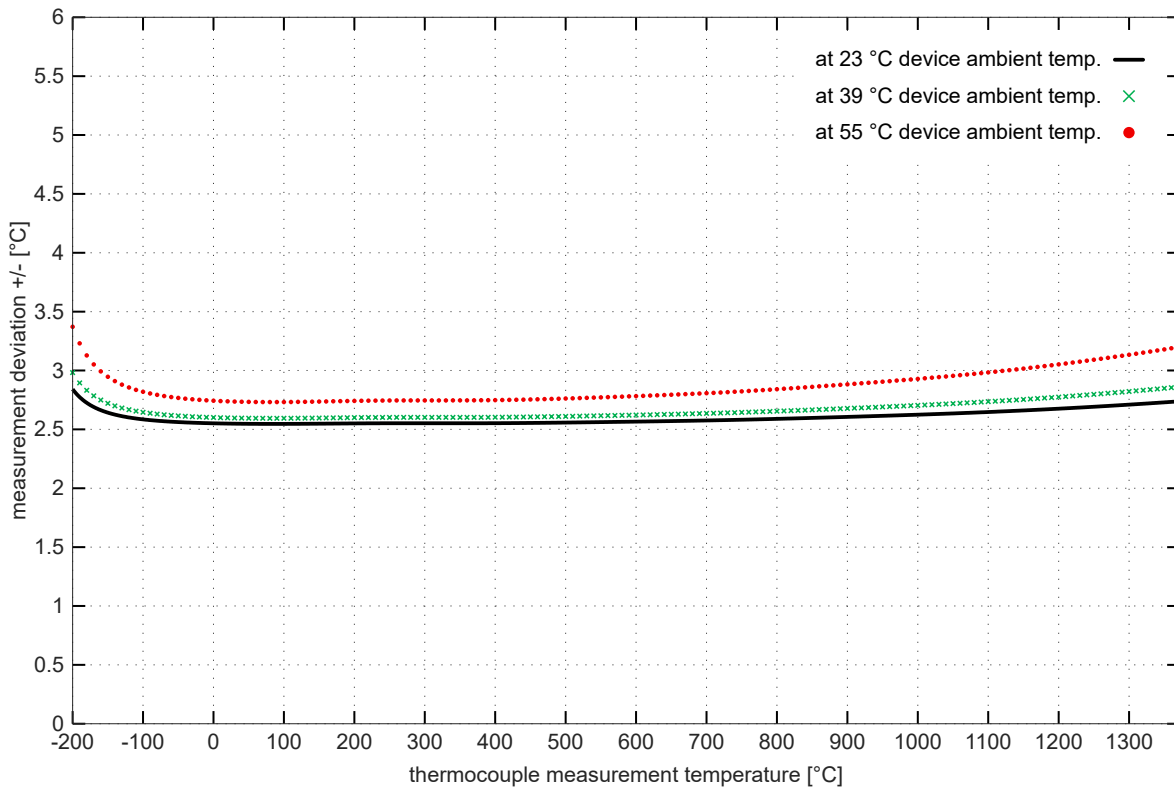

**Specification - thermocouple type L**

Temperature measurement thermocouple		Type L
Electrical measuring range used		± 75 mV
Measuring range, technically usable		0 °C ≈ 0 mV ... +900 °C ≈ 52.430 mV
Measuring range, end value (full scale value)		+900 °C
Measuring range, recommended		0 °C ... +900 °C
PDO LSB		0.1 / 0.01 °C/digit, depending on PDO setting Note: internally, 16 bits are used for the calculation up to the FSV; depending on the set thermocouple, therefore, jumps in value >0.01 °C occur with "resolution 0.01 °C"; e.g. type L: approx. 0.03 °C
Uncertainty in the recommended measuring range, with averaging	@ 23 °C ambient temperature	± 2.6 K ≈ ± 0.29 % <sub>FSV</sub>
	@ 55 °C ambient temperature	± 2.8 K ≈ ± 0.31 % <sub>FSV</sub>
Temperature coefficient (Change in the measured value in relation to the change in the ambient temperature of the terminal)		<i>Since the value is highly dependent on the sensor temperature, as can be seen in the specification plot shown below, it must basically be derived from the specification plot. For better approximation, the measurement uncertainty at T<sub>amb</sub> = 39 °C as the middle point between 23 °C and 55 °C is also shown informatively in order to illustrate the non-linear curve.</i>

Measurement uncertainty for thermocouple type L:

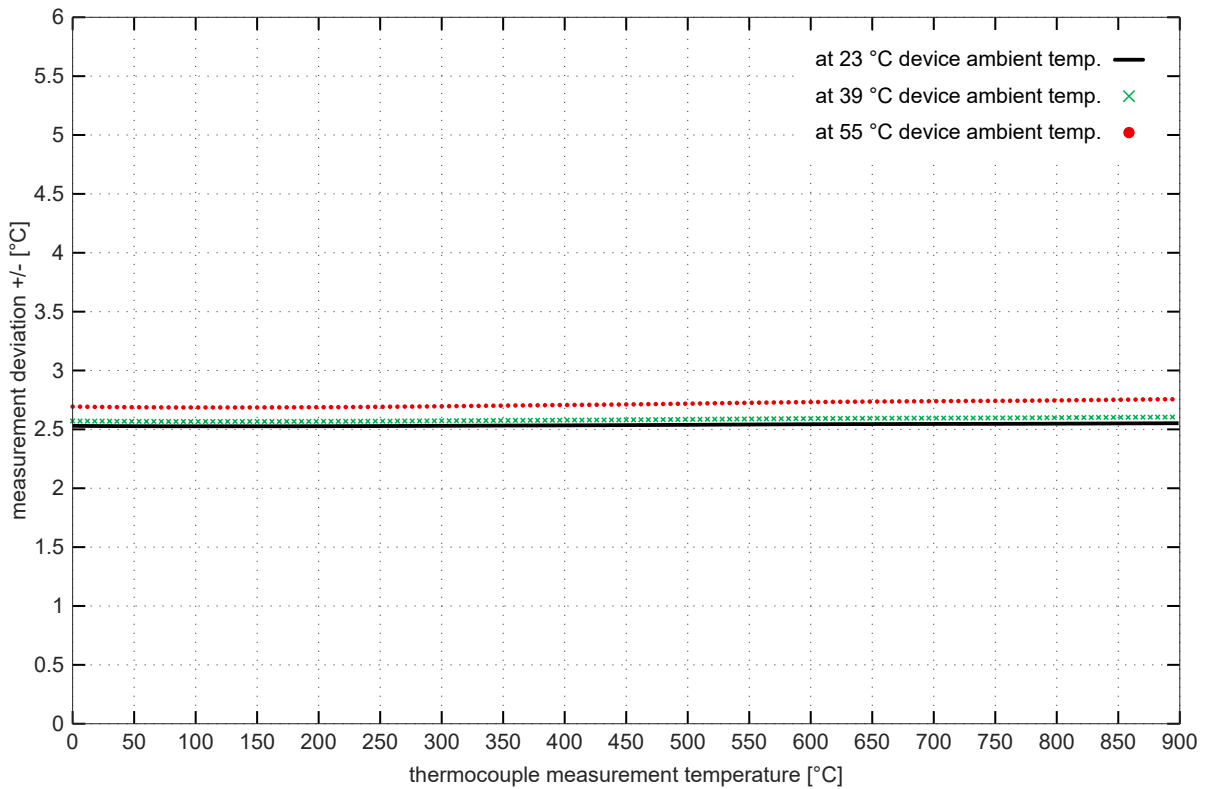

**Specification - thermocouple type N**

Temperature measurement thermocouple		Type N
Electrical measuring range used		± 75 mV
Measuring range, technically usable		-100 °C ≈ -2.406 mV ... +1300 °C ≈ 47.513 mV
Measuring range, end value (full scale value)		+1300 °C
Measuring range, recommended		0 °C ... +1200 °C
PDO LSB		0.1 / 0.01 °C/digit, depending on PDO setting Note: internally, 16 bits are used for the calculation up to the FSV; depending on the set thermocouple, therefore, jumps in value >0.01 °C occur with "resolution 0.01 °C"; e.g. type N: approx. 0.04 °C
Uncertainty in the recommended measuring range, with averaging	@ 23 °C ambient temperature	± 2.6 K ≈ ± 0.20 % <sub>FSV</sub>
	@ 55 °C ambient temperature	± 3.0 K ≈ ± 0.23 % <sub>FSV</sub>
Temperature coefficient (Change in the measured value in relation to the change in the ambient temperature of the terminal)		<i>Since the value is highly dependent on the sensor temperature, as can be seen in the specification plot shown below, it must basically be derived from the specification plot. For better approximation, the measurement uncertainty at T<sub>amb</sub> = 39 °C as the middle point between 23 °C and 55 °C is also shown informatively in order to illustrate the non-linear curve.</i>

Measurement uncertainty for thermocouple type N:

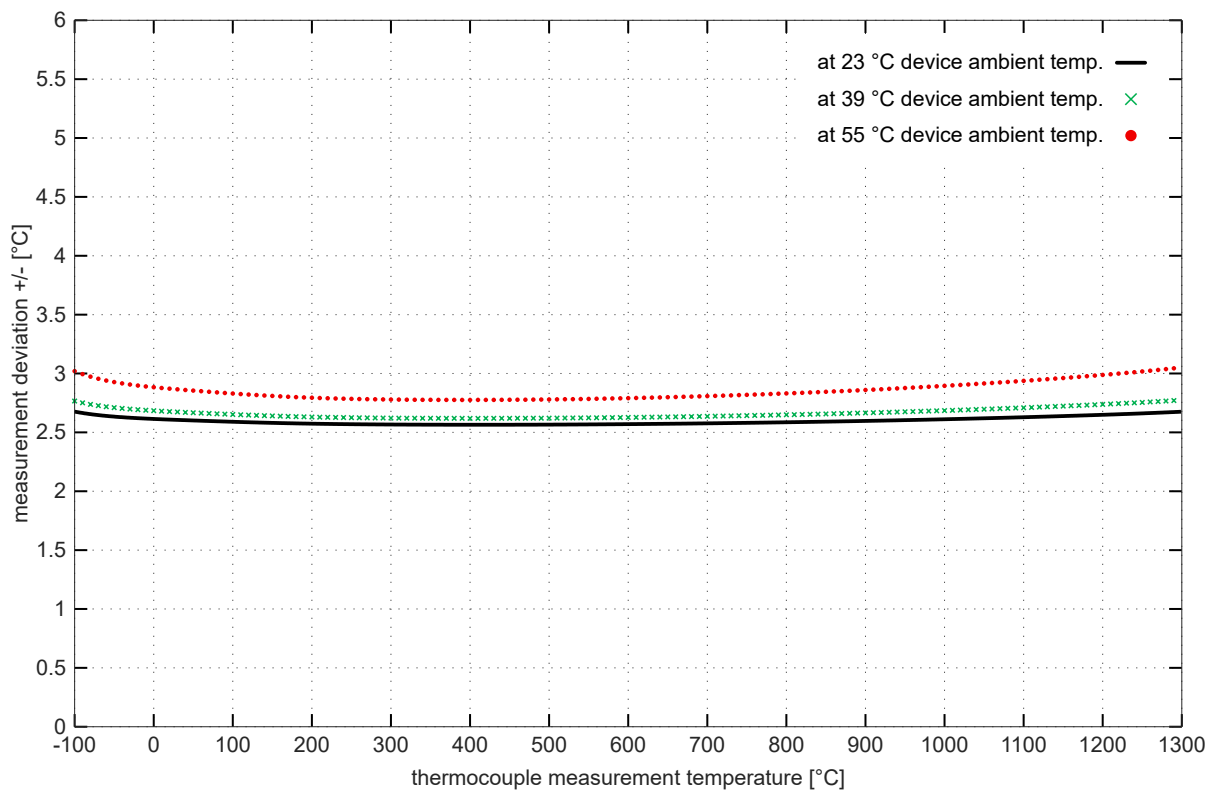



Specification - thermocouple type R

Temperature measurement thermocouple		Type R
Electrical measuring range used		± 75 mV
Measuring range, technically usable		-50 °C ≈ -0.226 mV ... +1767 °C ≈ 21.089 mV
Measuring range, end value (full scale value)		+1767 °C
Measuring range, recommended		250 °C ... +1700 °C
PDO LSB		0.1 / 0.01 °C/digit, depending on PDO setting Note: internally, 16 bits are used for the calculation up to the FSV; depending on the set thermocouple, therefore, jumps in value >0.01 °C occur with "resolution 0.01 °C"; e.g. type R: approx. 0.05 °C
Uncertainty in the recommended measuring range, with averaging	@ 23 °C ambient temperature	± 3.3 K ≈ ± 0.19 % <sub>FSV</sub>
	@ 55 °C ambient temperature	± 4.3 K ≈ ± 0.24 % <sub>FSV</sub>
Temperature coefficient (Change in the measured value in relation to the change in the ambient temperature of the terminal)		<i>Since the value is highly dependent on the sensor temperature, as can be seen in the specification plot shown below, it must basically be derived from the specification plot. For better approximation, the measurement uncertainty at T<sub>amb</sub> = 39 °C as the middle point between 23 °C and 55 °C is also shown informatively in order to illustrate the non-linear curve.</i>

Measurement uncertainty for thermocouple type R:

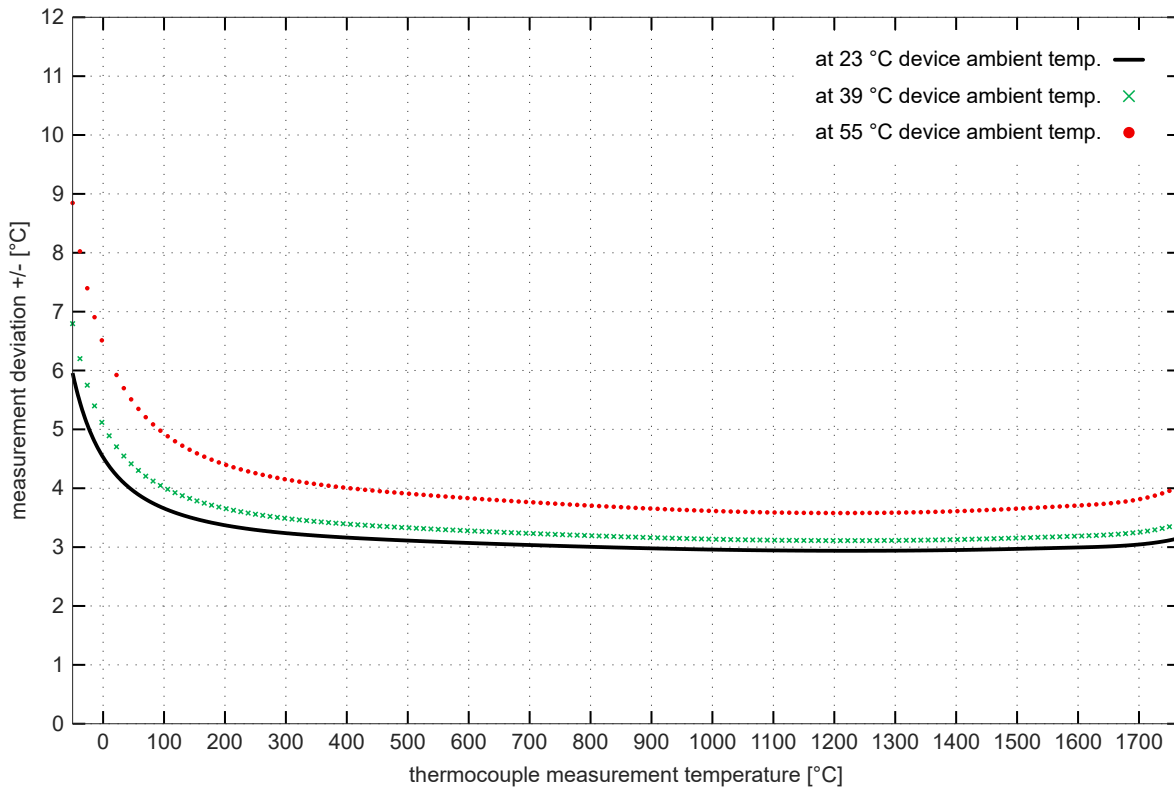

**Specification - thermocouple type S**

Temperature measurement thermocouple		Type S
Electrical measuring range used		± 75 mV
Measuring range, technically usable		-50 °C ≈ -0.236 mV ... +1760 °C ≈ 17.947 mV
Measuring range, end value (full scale value)		+1760 °C
Measuring range, recommended		250 °C ... +1700 °C
PDO LSB		0.1 / 0.01 °C/digit, depending on PDO setting Note: internally, 16 bits are used for the calculation up to the FSV; depending on the set thermocouple, therefore, jumps in value >0.01 °C occur with "resolution 0.01 °C"; e.g. type S: approx. 0.05 °C
Uncertainty in the recommended measuring range, with averaging	@ 23 °C ambient temperature	± 3.4 K ≈ ± 0.19 % <sub>FSV</sub>
	@ 55 °C ambient temperature	± 4.4 K ≈ ± 0.25 % <sub>FSV</sub>
Temperature coefficient (Change in the measured value in relation to the change in the ambient temperature of the terminal)		<i>Since the value is highly dependent on the sensor temperature, as can be seen in the specification plot shown below, it must basically be derived from the specification plot. For better approximation, the measurement uncertainty at T<sub>amb</sub> = 39 °C as the middle point between 23 °C and 55 °C is also shown informatively in order to illustrate the non-linear curve.</i>

Measurement uncertainty for thermocouple type S:

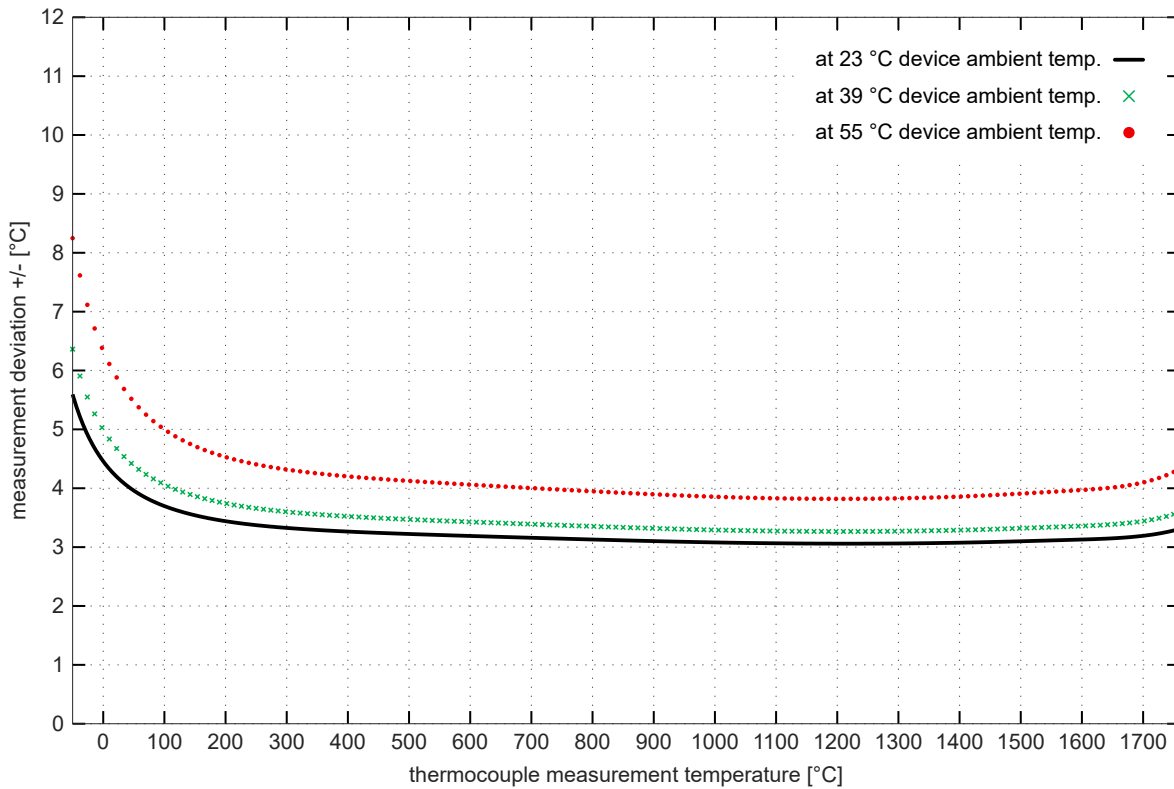

**Specification - thermocouple type T**

Temperature measurement thermocouple		Type T
Electrical measuring range used		± 75 mV
Measuring range, technically usable		-200 °C ≈ -5.603 mV ... +400 °C ≈ 20.872 mV
Measuring range, end value (full scale value)		+400 °C
Measuring range, recommended		-100 °C ... +400 °C
PDO LSB		0.1 / 0.01 °C/digit, depending on PDO setting
Uncertainty in the recommended measuring range, with averaging	@ 23 °C ambient temperature	± 2.6 K ≈ ± 0.65 % <sub>FSV</sub>
	@ 55 °C ambient temperature	± 2.9 K ≈ ± 0.73 % <sub>FSV</sub>
Temperature coefficient (Change in the measured value in relation to the change in the ambient temperature of the terminal)		<i>Since the value is highly dependent on the sensor temperature, as can be seen in the specification plot shown below, it must basically be derived from the specification plot. For better approximation, the measurement uncertainty at <math>T_{amb} = 39\text{ °C}</math> as the middle point between 23 °C and 55 °C is also shown informatively in order to illustrate the non-linear curve.</i>

Measurement uncertainty for thermocouple type T:

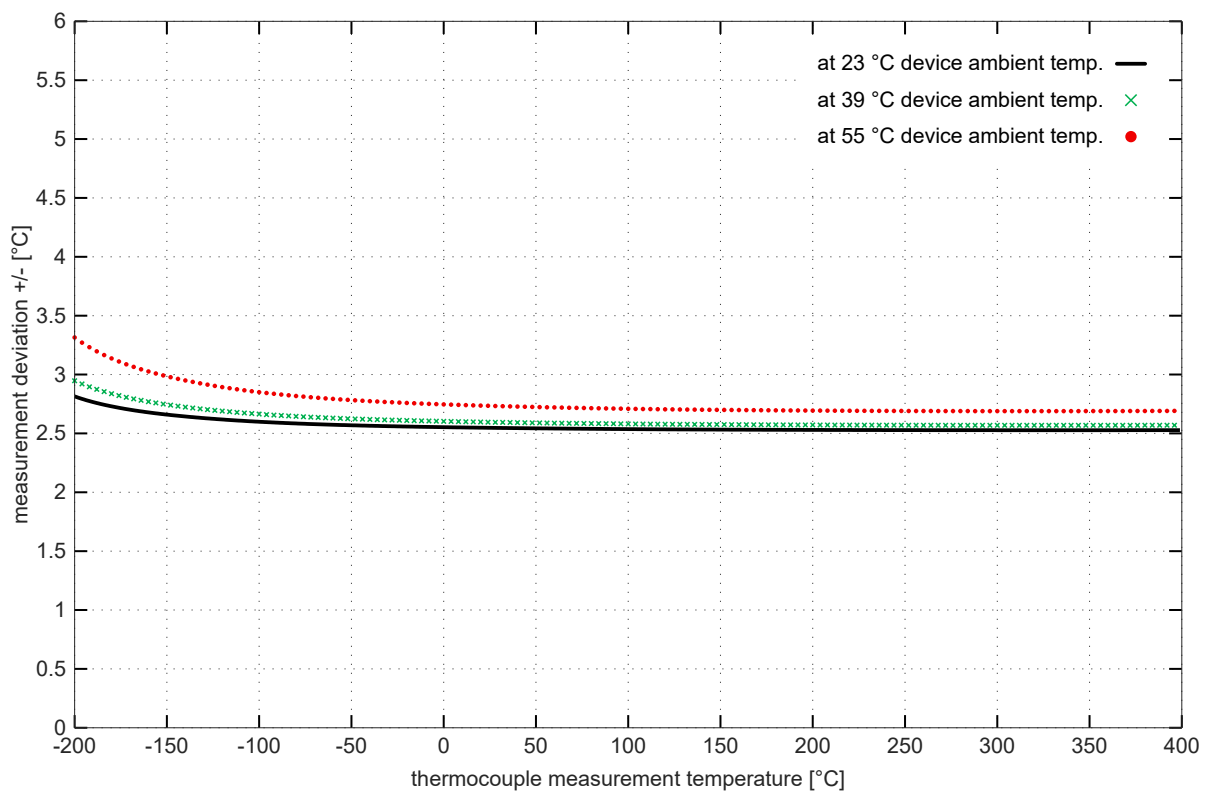

**Specification - thermocouple type U**

Temperature measurement thermocouple		Type U
Electrical measuring range used		± 75 mV
Measuring range, technically usable		0 °C ≈ 0 mV ... +600 °C ≈ 33.600 mV
Measuring range, end value (full scale value)		+600 °C
Measuring range, recommended		0 °C ... +600 °C
PDO LSB		0.1 / 0.01 °C/digit, depending on PDO setting Note: internally, 16 bits are used for the calculation up to the FSV; depending on the set thermocouple, therefore, jumps in value >0.01 °C occur with "resolution 0.01 °C"; e.g. type U: approx. 0.02 °C
Uncertainty in the recommended measuring range, with averaging	@ 23 °C ambient temperature	± 2.6 K ≈ ± 0.43 % <sub>FSV</sub>
	@ 55 °C ambient temperature	± 2.7 K ≈ ± 0.45 % <sub>FSV</sub>
Temperature coefficient (Change in the measured value in relation to the change in the ambient temperature of the terminal)		<i>Since the value is highly dependent on the sensor temperature, as can be seen in the specification plot shown below, it must basically be derived from the specification plot. For better approximation, the measurement uncertainty at T<sub>amb</sub> = 39 °C as the middle point between 23 °C and 55 °C is also shown informatively in order to illustrate the non-linear curve.</i>

Measurement uncertainty for thermocouple type U:

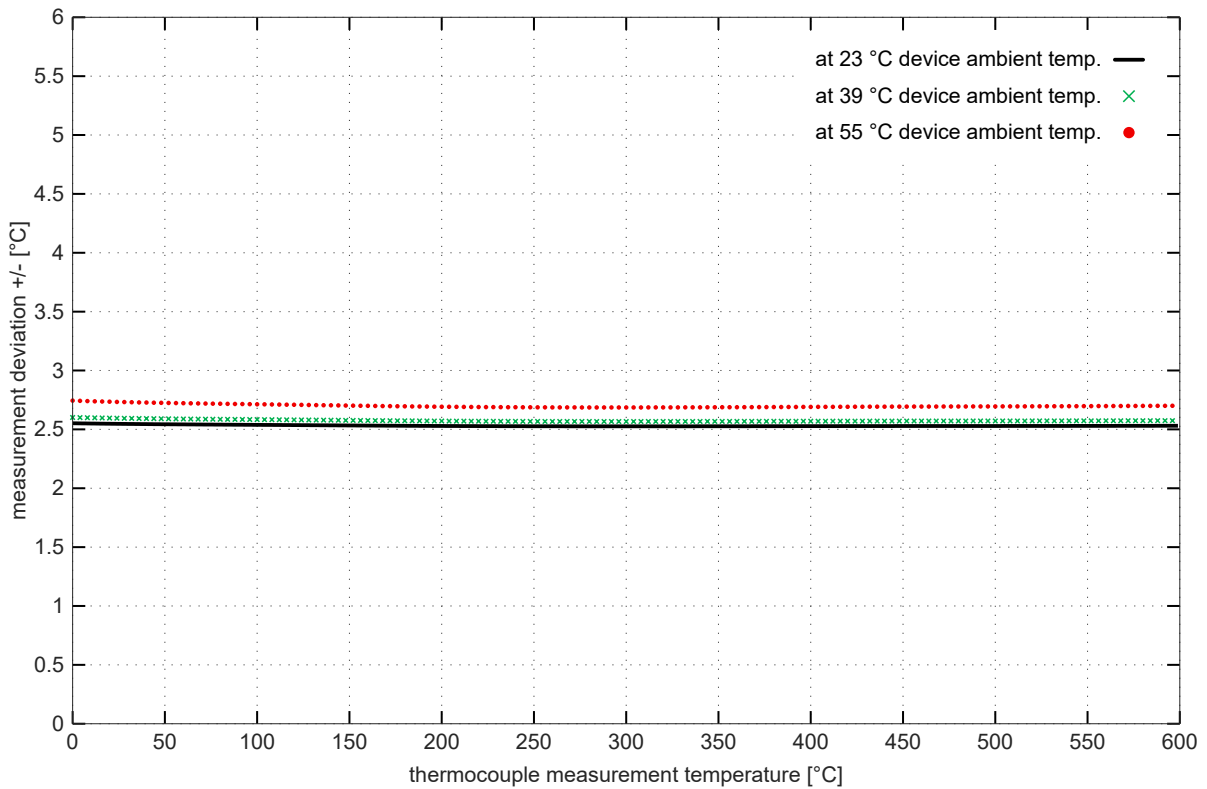

## 4.3 Process image

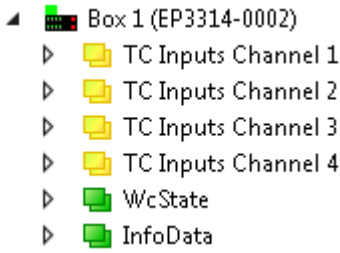
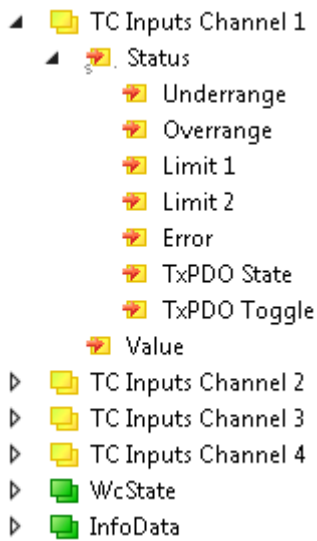

Fig. 2: Process image

### TC Inputs Channel 1



- Underrange  
Measurement is below range
- Overrange  
Measuring range exceeded
- Limit 1  
Status variable of the limit value monitoring
  - 0: The limit value monitoring is disabled
  - 1: The measured value is smaller than the limit value
  - 2: The measured value is greater than the limit value
  - 3: The measured value is exactly the same size as the limit value
- Limit 2  
Status variable of the limit value monitoring
- Error  
The current measured value "Value" is invalid.  
Possible reasons: Wire breakage, Underrange, Overrange
- TxPDO State  
If this bit is TRUE, the current measured value "Value" is invalid.
- TxPDO Toggle  
The box inverts this bit every time it updates the measured value "Value" in the process data.  
This allows the currently required conversion time to be derived.

Value  
The current measured value. Unit: 1/10 °C.

### TC Inputs Channel 2 bis 4

The process data objects of channels 2...4 have exactly the same structure as those of channel 1.

## 4.4 Scope of supply

Make sure that the following components are included in the scope of delivery:

- 1x EtherCAT Box EP3314-0002
- 1x protective cap for supply voltage input, M8, transparent (pre-assembled)
- 1x protective cap for supply voltage output, M8, black (pre-assembled)
- 2x protective cap for EtherCAT socket, M8, green (pre-assembled)
- 10x labels, blank (1 strip of 10)

---

### **● Pre-assembled protective caps do not ensure IP67 protection**

**i** Protective caps are pre-assembled at the factory to protect connectors during transport. They may not be tight enough to ensure IP67 protection.

Ensure that the protective caps are correctly seated to ensure IP67 protection.

---

## 4.5 Basics of thermocouple technology

The basics of the strain gauge technology can be found in the I/O Analog Manual: [Link](#)

## 5 Mounting and connection

### 5.1 Mounting

#### 5.1.1 Dimensions

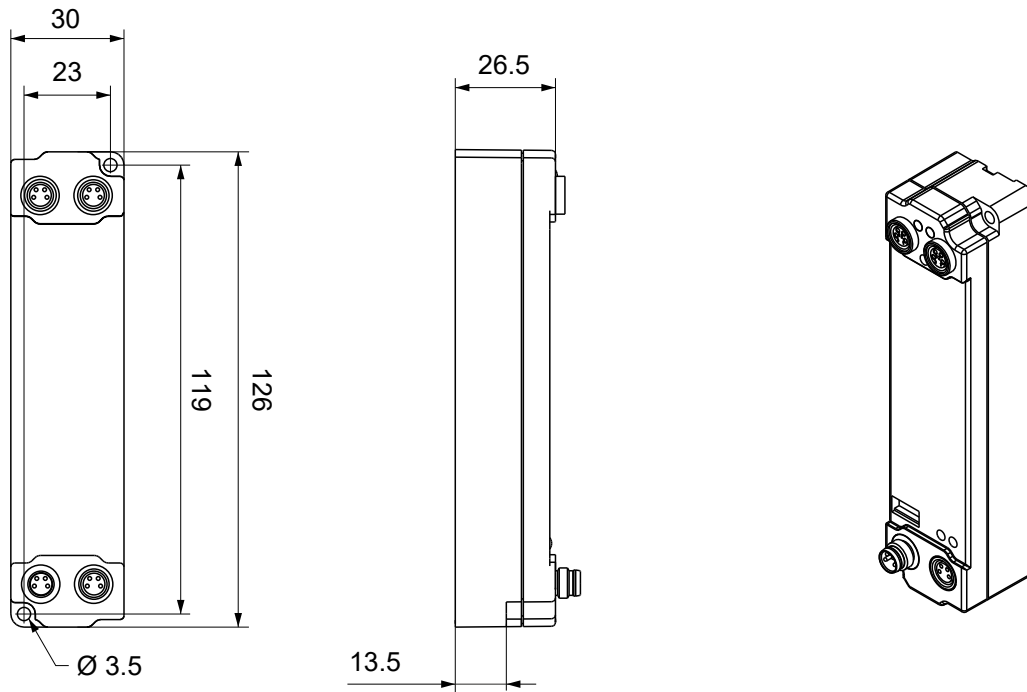

All dimensions are given in millimeters.  
The drawing is not true to scale.

#### Housing features

Housing material	PA6 (polyamide)
Sealing compound	polyurethane
Mounting	two mounting holes $\varnothing 3.5$ mm for M3
Metal parts	brass, nickel-plated
Contacts	CuZn, gold-plated
Power feed through	max. 4 A
Installation position	variable
Protection class	IP65, IP66, IP67 (conforms to EN 60529) when screwed together
Dimensions (H x W x D)	approx. 126 x 30 x 26.5 mm (without connectors)



## 5.1.2 Fixing

### NOTICE

#### Dirt during assembly

Dirty connectors can lead to malfunctions. Protection class IP67 can only be guaranteed if all cables and connectors are connected.

- Protect the plug connectors against dirt during the assembly.

Mount the module with two M3 screws on the mounting holes in the corners of the module. The mounting holes have no thread.

## 5.1.3 Tightening torques for plug connectors

Screw connectors tight with a torque wrench. (e.g. ZB8801 from Beckhoff)

Connector diameter	Tightening torque
M8	0.4 Nm
M12	0.6 Nm

## 5.2 Connection

### 5.2.1 Supply voltages

#### ⚠ WARNING

##### Power supply from SELV/PELV power supply unit!

SELV/PELV circuits (Safety Extra Low Voltage, Protective Extra Low Voltage) according to IEC 61010-2-201 must be used to supply this device.

Notes:

- SELV/PELV circuits may give rise to further requirements from standards such as IEC 60204-1 et al, for example with regard to cable spacing and insulation.
- A SELV (Safety Extra Low Voltage) supply provides safe electrical isolation and limitation of the voltage without a connection to the protective conductor, a PELV (Protective Extra Low Voltage) supply also requires a safe connection to the protective conductor.

#### ⚠ CAUTION

##### Observe the UL requirements

- When operating under UL conditions, observe the warnings in the chapter [UL Requirements](#) [▶ 44].

The EtherCAT Box has one input for two supply voltages:

- **Control voltage  $U_s$**   
The following sub-functions are supplied from the control voltage  $U_s$ :
  - the fieldbus
  - the processor logic
  - typically the inputs and the sensors if the EtherCAT Box has inputs.
- **Peripheral voltage  $U_p$**   
For EtherCAT Box modules with digital outputs the digital outputs are typically supplied from the peripheral voltage  $U_p$ .  $U_p$  can be supplied separately. If  $U_p$  is switched off, the fieldbus function, the function of the inputs and the supply of the sensors are maintained.

The exact assignment of  $U_s$  and  $U_p$  can be found in the pin assignment of the I/O connections.

#### Redirection of the supply voltages

The power IN and OUT connections are bridged in the module. Hence, the supply voltages  $U_s$  and  $U_p$  can be passed from EtherCAT Box to EtherCAT Box in a simple manner.

#### NOTICE

##### Note the maximum current!

Ensure that the permitted current for the connectors is not exceeded when routing the supply voltages  $U_s$  and  $U_p$ :

M8 connector: max. 4 A  
7/8" connector: max 16 A

#### NOTICE

##### Unintentional cancellation of the electrical isolation of $GND_s$ and $GND_p$ possible.

In some types of EtherCAT Box modules the ground potentials  $GND_s$  and  $GND_p$  are connected.

- If several EtherCAT Box modules are supplied with the same electrically isolated voltages, check whether there is an EtherCAT Box among them in which the ground potentials are connected.

5.2.1.1 Connectors

**NOTICE**

**Risk of confusion: supply voltages and EtherCAT**

Defect possible through incorrect insertion.

- Observe the color coding of the connectors:  
 black: Supply voltages  
 green: EtherCAT

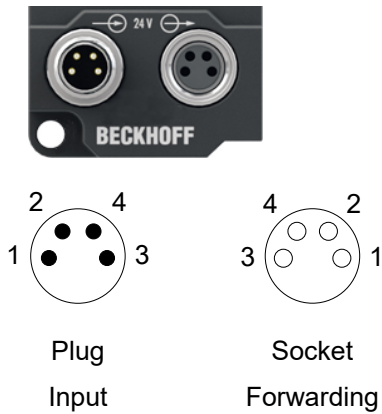

Fig. 3: M8 connector

Contact	Function	Description	Core color <sup>1)</sup>
1	U <sub>S</sub>	Control voltage	Brown
2	U <sub>P</sub>	Peripheral voltage	White
3	GND <sub>S</sub>	GND to U <sub>S</sub>	Blue
4	GND <sub>P</sub>	GND to U <sub>P</sub>	Black

<sup>1)</sup> The core colors apply to cables of the type: Beckhoff ZK2020-3xxx-xxxx

5.2.1.2 Status LEDs



LED	Display	Meaning
U <sub>S</sub> (control voltage)	off	The supply voltage U <sub>S</sub> is not available.
	green illuminated	The supply voltage U <sub>S</sub> is available.
U <sub>P</sub> (peripheral voltage)	off	The supply voltage U <sub>P</sub> is not available.
	green illuminated	The supply voltage U <sub>P</sub> is available.

### 5.2.1.3 Conductor losses

Take into account the voltage drop on the supply line when planning a system. Avoid the voltage drop being so high that the supply voltage at the box lies below the minimum nominal voltage. Variations in the voltage of the power supply unit must also be taken into account.

#### Voltage drop on the supply line

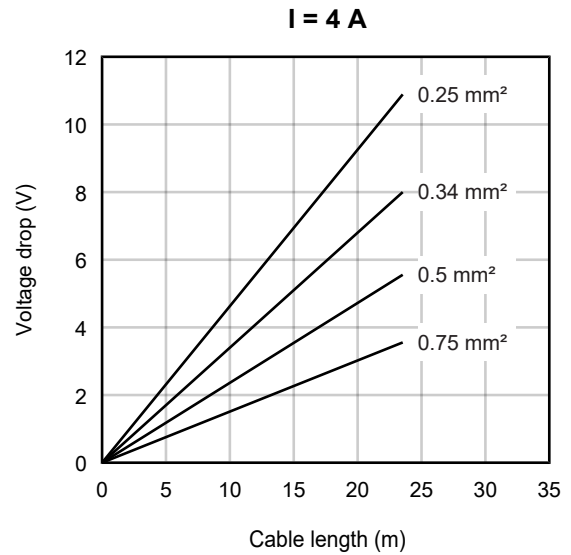
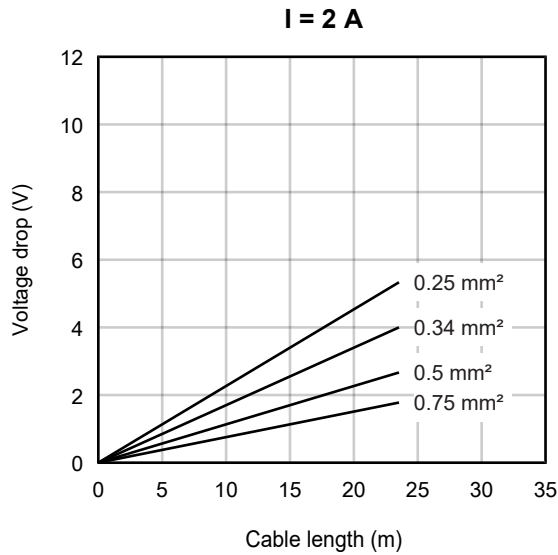

## 5.2.2 EtherCAT

### 5.2.2.1 Connectors

**NOTICE**

**Risk of confusion: supply voltages and EtherCAT**

Defect possible through incorrect insertion.

- Observe the color coding of the connectors:  
 black: Supply voltages  
 green: EtherCAT

EtherCAT Box Modules have two green M8 sockets for the incoming and downstream EtherCAT connections.



**Connection**

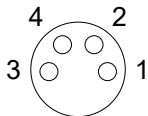

Fig. 4: M8 socket

EtherCAT	M8 socket	Core colors		
Signal	Contact	ZB9010, ZB9020, ZB9030, ZB9032, ZK1090-6292, ZK1090-3xxx-xxxx	ZB9031 and old versions of ZB9030, ZB9032, ZK1090-3xxx-xxxx	TIA-568B
Tx +	1	yellow <sup>1)</sup>	orange/white	white/orange
Tx -	4	orange <sup>1)</sup>	orange	orange
Rx +	2	white <sup>1)</sup>	blue/white	white/green
Rx -	3	blue <sup>1)</sup>	blue	green
Shield	Housing	Shield	Shield	Shield

<sup>1)</sup> Core colors according to EN 61918

**● Adaptation of core colors for cables ZB9030, ZB9032 and ZK1090-3xxxx-xxxx**

**i** For standardization, the core colors of the ZB9030, ZB9032 and ZK1090-3xxx-xxxx cables have been changed to the EN61918 core colors: yellow, orange, white, blue. So there are different color codes in circulation. The electrical properties of the cables have been retained when the core colors were changed.

### 5.2.2.2 Status LEDs



#### L/A (Link/Act)

A green LED labelled "L/A" is located next to each EtherCAT socket. The LED indicates the communication state of the respective socket:

LED	Meaning
off	no connection to the connected EtherCAT device
lit	LINK: connection to the connected EtherCAT device
flashes	ACT: communication with the connected EtherCAT device

#### Run

Each EtherCAT slave has a green LED labelled "Run". The LED signals the status of the slave in the EtherCAT network:

LED	Meaning
off	Slave is in "Init" state
flashes uniformly	Slave is in "Pre-Operational" state
flashes sporadically	Slave is in "Safe-Operational" state
lit	Slave is in "Operational" state

Description of the EtherCAT slave states

### 5.2.2.3 Cables

For connecting EtherCAT devices only shielded Ethernet cables that meet the requirements of at least category 5 (CAT5) according to EN 50173 or ISO/IEC 11801 should be used.

EtherCAT uses four wires for signal transmission.

Thanks to automatic line detection ("Auto MDI-X"), both symmetrical (1:1) or cross-over cables can be used between Beckhoff EtherCAT.

Detailed recommendations for the cabling of EtherCAT devices

## 5.2.3 Signal connection

### 5.2.3.1 EP3204: Pt100 (RTD)

The advantage of four-wire technique is that the error resulting from the cable and contacts is included in the measurement and cancelled out. In the 3-wire technique, the line resistance to the resistance sensor is measured in one direction only, and is multiplied by two. This requires the outward and return lines to have approximately the same ohmic resistance. An error is present in the two-wire technique; temperature differences and cable cross-sections can make this error vary considerably.

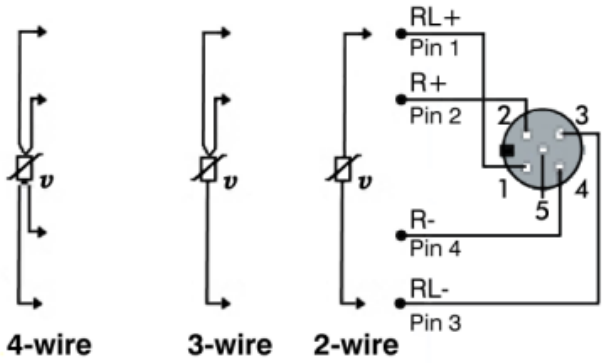

### 5.2.3.2 EP3314: Thermocouples

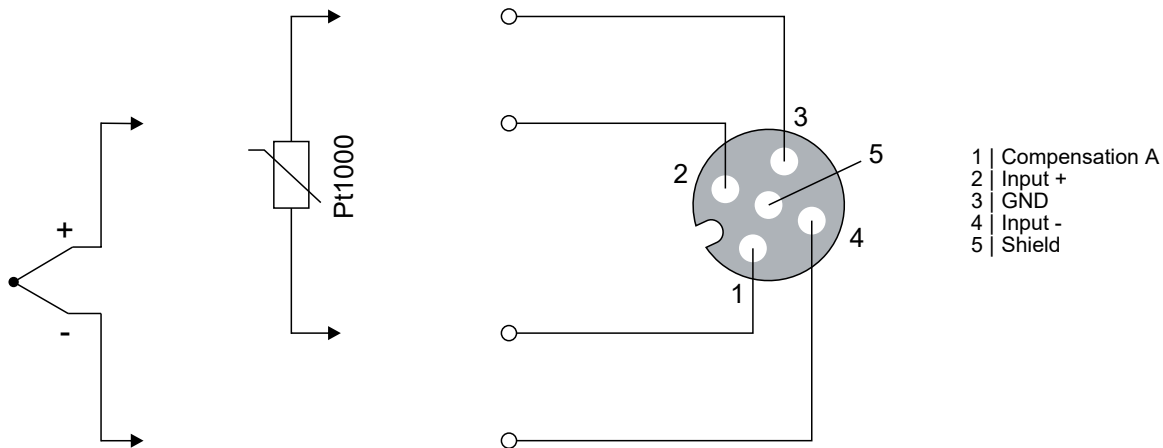

#### Cold junction compensation

The cold junction temperature is not measured in the box. For cold junction compensation, a Pt1000 measuring resistor must be connected in addition to the thermocouple. Place the Pt1000 measuring resistor as close as possible to the cold junction.

Recommendation: Use the ZS2000-3712 connector from Beckhoff instead of a separate Pt1000 measuring resistor. The ZS2000-3712 has an integrated Pt1000 measuring resistor that measures the temperature directly at the cold junction.

The highest accuracy can be achieved if a ZS2000-3712 or a Pt1000 measuring resistor is used for each connection. See [Connection example 1 \[► 41\]](#)

Alternatively, you can save costs by connecting a ZS2000-3712 or a Pt1000 measuring resistor to channel 1 only. In this case cold junction compensation of the other channels is carried out with the cold junction temperature of channel 1. See [Connection example 2 \[► 42\]](#).

#### Extension cable

You can use an M12 extension cable between the box and the cold junction. However, this reduces the measuring accuracy. The longer the extension cable, the greater the measuring error.

The maximum permissible cable length between the box and the thermocouple is 30 m.



5.2.3.2.1 Connection example 1

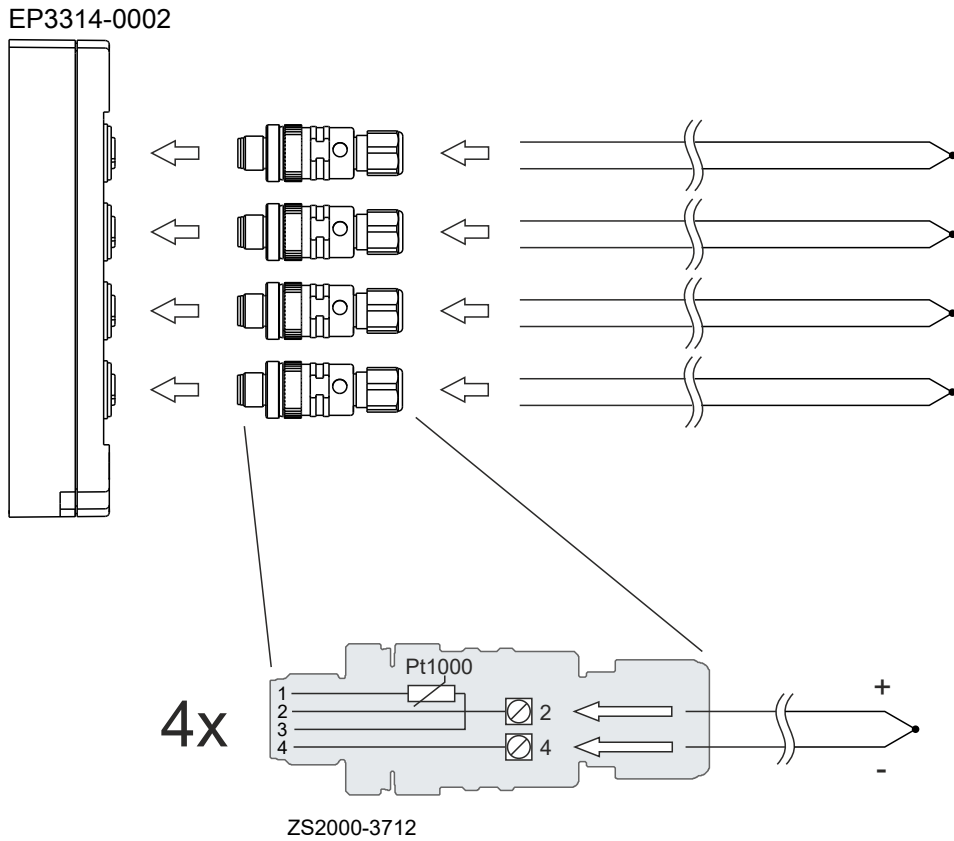

In this connection example, four connectors of type ZS2000-3712 with integrated measuring resistor are used. Cold junction compensation is performed for each channel individually.

The CoE parameters 80n0:0C "Coldjunction compensation" must be set to the value 0 "intern" for all channels. This is the factory setting. See chapter [Cold junction compensation \[► 78\]](#).

**5.2.3.2.2 Connection example 2**

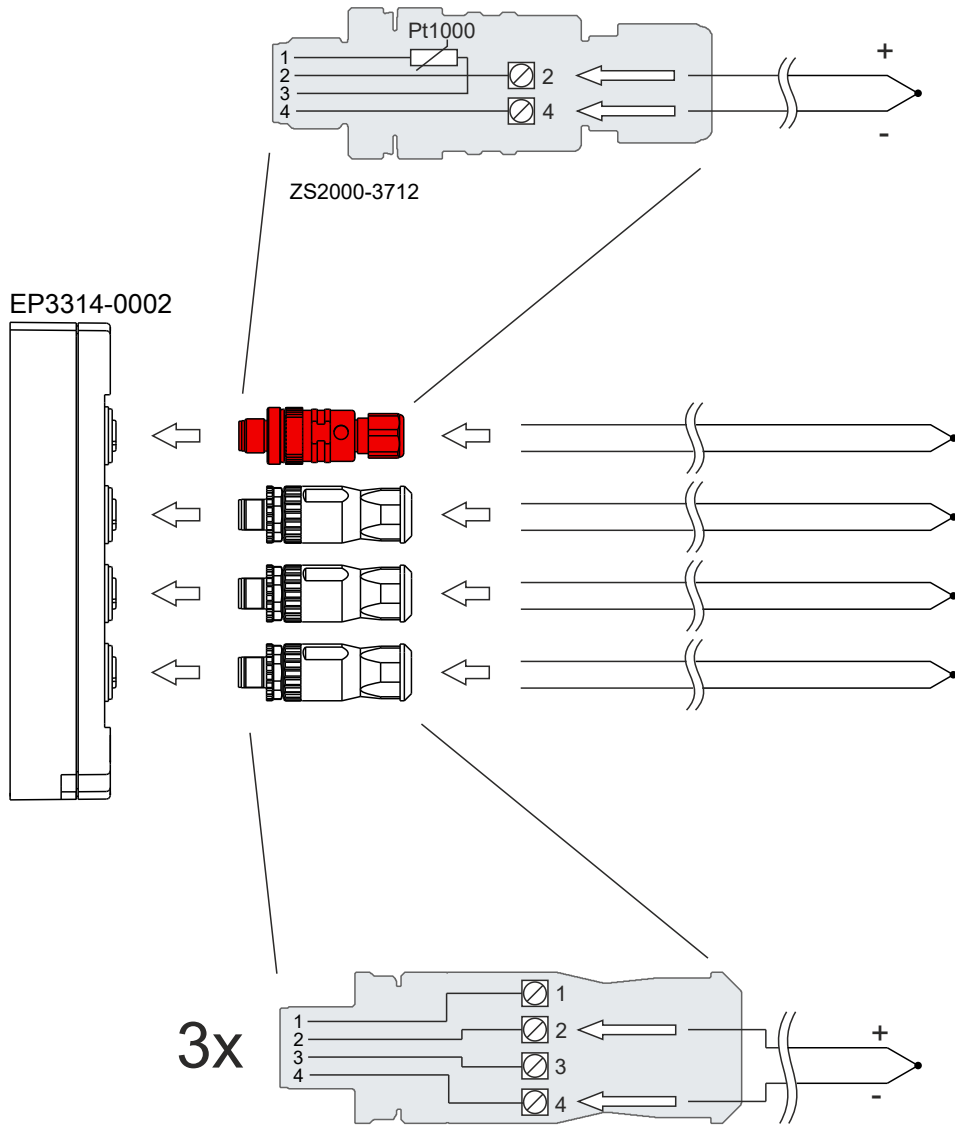

In this connection example only one connector with integrated measuring resistor type ZS2000-3712 is used. The thermocouples are connected to the other channels via standard M12 connectors.

Set the CoE parameters of the channels as follows:

CoE parameters	Value
8000:0C <sub>hex</sub>	0 "internal"
8010:0C <sub>hex</sub>	3 „by coldjunction temp. of channel 1“
8020:0C <sub>hex</sub>	3 „by coldjunction temp. of channel 1“
8030:0C <sub>hex</sub>	3 „by coldjunction temp. of channel 1“

See chapter [Cold junction compensation](#) [► 78].

### 5.2.3.3 Status LEDs at the signal connections

There is a green *Run* LED and a red *Error* LED for each channel.  
 Correct function is indicated if the green *Run* LED is on and the red *Error* is off.

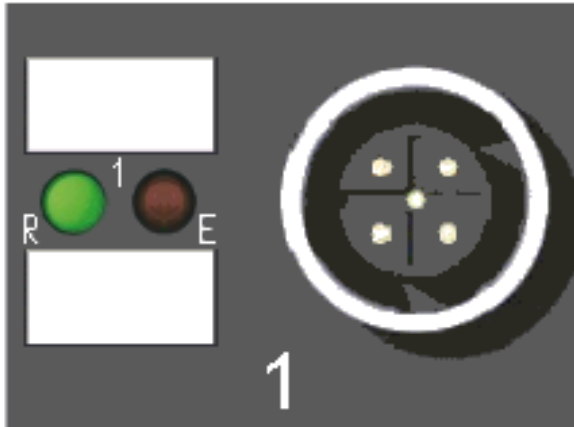

Fig. 5: Status LEDs at the signal connections

Connection	LED	Display	Meaning
M12 socket no. 1-4	R left	off	No data transfer to the A/D converter
		green	Data transfer to A/D converter
	E right	off	Function OK
		red	Error: <ul style="list-style-type: none"> <li>• Broken wire or</li> <li>• measured value outside measuring range or</li> <li>• temperature compensation outside the valid range</li> </ul>

## 5.3 UL Requirements

The installation of the EtherCAT Box Modules certified by UL has to meet the following requirements.

### Supply voltage

#### ⚠ CAUTION

##### CAUTION!

This UL requirements are valid for all supply voltages of all marked EtherCAT Box Modules!  
For the compliance of the UL requirements the EtherCAT Box Modules should only be supplied

- by a 24 V<sub>DC</sub> supply voltage, supplied by an isolating source and protected by means of a fuse (in accordance with UL248), rated maximum 4 Amp, or
- by a 24 V<sub>DC</sub> power source, that has to satisfy *NEC class 2*.  
A *NEC class 2* power supply shall not be connected in series or parallel with another (class 2) power source!

#### ⚠ CAUTION

##### CAUTION!

To meet the UL requirements, the EtherCAT Box Modules must not be connected to unlimited power sources!

### Networks

#### ⚠ CAUTION

##### CAUTION!

To meet the UL requirements, EtherCAT Box Modules must not be connected to telecommunication networks!

### Ambient temperature range

#### ⚠ CAUTION

##### CAUTION!

To meet the UL requirements, EtherCAT Box Modules has to be operated only at an ambient temperature range of -25 °C to +55 °C!

### Marking for UL

All EtherCAT Box Modules certified by UL (Underwriters Laboratories) are marked with the following label.



Fig. 6: UL label

## 5.4 ATEX notes

### 5.4.1 ATEX - Special conditions

#### WARNING

Observe the special conditions for the intended use of EtherCAT Box modules in potentially explosive areas – directive 94/9/EU.

- The certified components are to be installed with a BG2000-0000 or BG2000-0010 protection enclosure [► 46] that guarantees a protection against mechanical hazards!
- If the temperatures during rated operation are higher than 70°C at the feed-in points of cables, lines or pipes, or higher than 80°C at the wire branching points, then cables must be selected whose temperature data correspond to the actual measured temperature values!
- Observe the permissible ambient temperature range of 0 to 55°C for the use of EtherCAT Box modules in potentially explosive areas!
- Measures must be taken to protect against the rated operating voltage being exceeded by more than 40% due to short-term interference voltages!
- The connections of the certified components may only be connected or disconnected if the supply voltage has been switched off or if a non-explosive atmosphere is ensured!

#### Standards

The fundamental health and safety requirements are fulfilled by compliance with the following standards:

- EN 60079-0: 2006
- EN 60079-15: 2005

#### Marking

The EtherCAT Box modules certified for potentially explosive areas bear the following marking:



II 3 G Ex nA II T4 DEKRA 11ATEX0080 X Ta: 0 - 55°C

or



II 3 G Ex nA nC IIC T4 DEKRA 11ATEX0080 X Ta: 0 - 55°C

#### Batch number (D number)

The EtherCAT Box modules bear a batch number (D number) that is structured as follows:

D: WW YY FF HH

WW - week of production (calendar week)

YY - year of production

FF - firmware version

HH - hardware version

Example with batch number 29 10 02 01:

29 - week of production 29

10 - year of production 2010

02 - firmware version 02

01 - hardware version 01

## 5.4.2 BG2000 - EtherCAT Box protection enclosures

### ⚠ WARNING

#### Risk of electric shock and damage of device!

Bring the EtherCAT system into a safe, powered down state before starting installation, disassembly or wiring of the modules!

### ATEX

### ⚠ WARNING

#### Mount a protection enclosure!

To fulfill the special conditions according to ATEX [▶ 45], a BG2000-0000 or BG2000-0010 protection enclosure has to be mounted over the EtherCAT Box.

### Installation

Put the cables for EtherCAT, power supply and sensors/actuators through the hole of the protection enclosure.

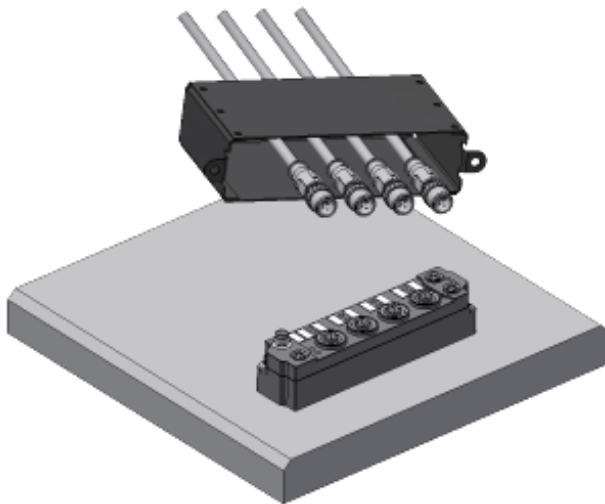

Fig. 7: BG2000 - putting the cables

Fix the wires for EtherCAT, power supply and sensors/actuators to the EtherCAT Box.

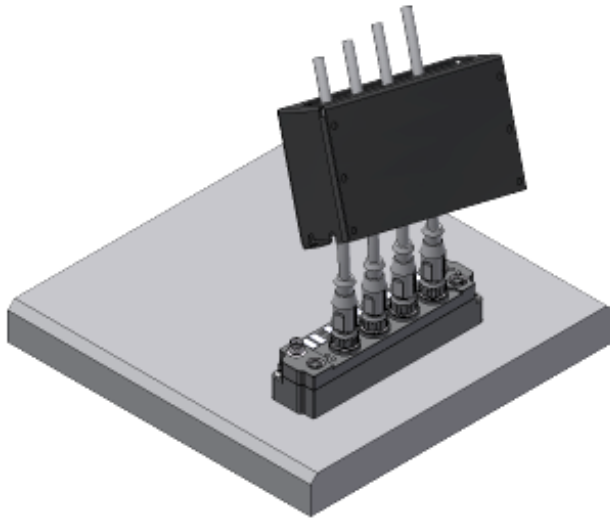

Fig. 8: BG2000 - fixing the cables

Mount the protection enclosure over the EtherCAT Box.

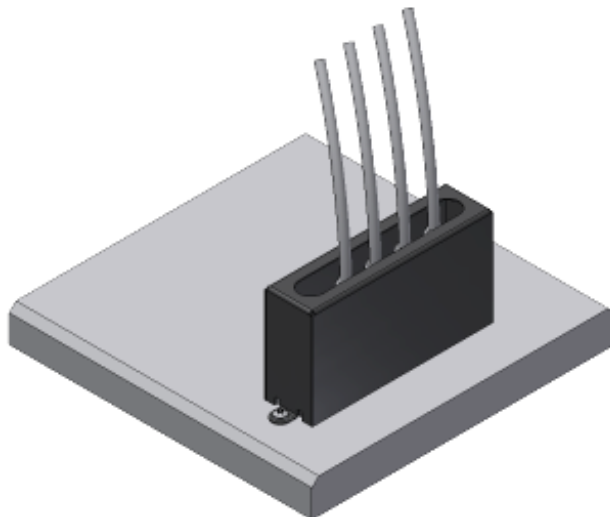

Fig. 9: BG2000 - mounting the protection enclosure

### 5.4.3 ATEX Documentation



#### **Notes about operation of EtherCAT Box Modules (EPxxxx-xxxx) in potentially explosive areas (ATEX)**

Pay also attention to the continuative documentation Notes about operation of EtherCAT Box Modules (EPxxxx-xxxx) in potentially explosive areas (ATEX) that is available in the download area of the Beckhoff homepage <http://www.beckhoff.com>!

## 5.5 Disposal



Products marked with a crossed-out wheeled bin shall not be discarded with the normal waste stream. The device is considered as waste electrical and electronic equipment. The national regulations for the disposal of waste electrical and electronic equipment must be observed.



## 6 Commissioning/Configuration

### 6.1 Integrating into a TwinCAT project

The procedure for integration in a TwinCAT project is described in these [Quick start guide](#).

### 6.2 EP3204 – Data stream and calculation of the process data

#### 6.2.1 Vendor calibration

##### 6.2.1.1 2 and 4-wire resistance measurement

Whether a measurement is executed as a 2 or 4-wire measurement is determined by the connection points at which the measurement takes place. A comparison value is stored in the firmware for both measuring methods.

- **With the 2-wire measurement**

- a current is applied between the contact points RL+ und RL- and the voltage drop is measured in order to determine the resistance.
- The parasitic line resistance cannot be determined by the box itself, but must be entered as a correction value in the CoE register 0x80n0:1B.

- **With the 4-wire measurement**

- the sensor current is applied between the contact points RL+ und RL- of the M12 socket and the voltage drop at the contact points R+ and R- is used to measure the resistance.
- The conducting wire is thus not part of the measuring circuit and is not incorporated into the measurement as a source of error.

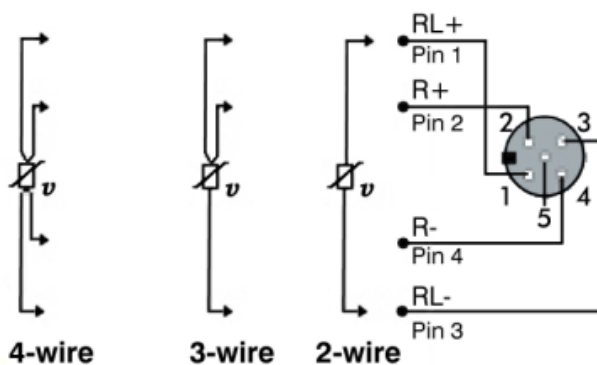

Fig. 10: Resistance measurement with a 4-wire, 3-wire and 2-wire connection technique

The box uses the following calculation rule:

$$Y_R = \frac{(X+O_V)}{2^2} \cdot G_V$$

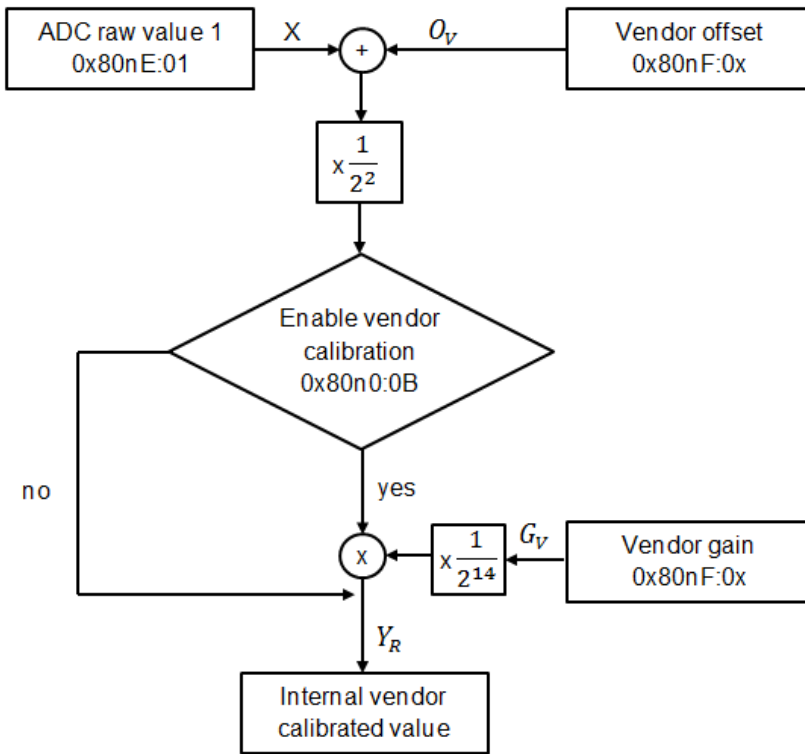

Fig. 11: Data flow: resistance measurement with a 2 and 4-wire connection technique

With the values:

	Index in the CoE directory with n: channel number with 0 ≤ n ≤ 3 (channel 1 - 4)			
X: Raw value	0x80nE:01			
	Pt100		Pt1000	
	2-wire	4-wire	2-wire	4-wire
Gv: Vendor Gain	0x80nF:04	0x80nF:06	0x80nF:0A	0x80nF:0C
Ov: Vendor Offset	0x80nF:03	0x80nF:05	0x80nF:09	0x80nF:0B
Y <sub>R</sub> : Output value in 1/256 Ω	0x80nE:02			



**Overflow Y<sub>R</sub> after 16 bits**

This value is only for fault finding. The register overflows after 16 bits, i.e. at 65536.

**6.2.1.2 3-wire resistance measurement**

• **With the 3-wire measurement**

- a defined current is initially applied between the contact points RL+ und RL- and the resistance between them is determined on the basis of the voltage drop.
- The same procedure is subsequently carried out at the contact points R+ und RL-.
- The difference between the two measurements is the line resistance of one of the cores of the sensor cable. By knowing the line resistance the resulting measuring error can be compensated.
- The cores of the sensor cable must have the same resistance in order for the method to work.

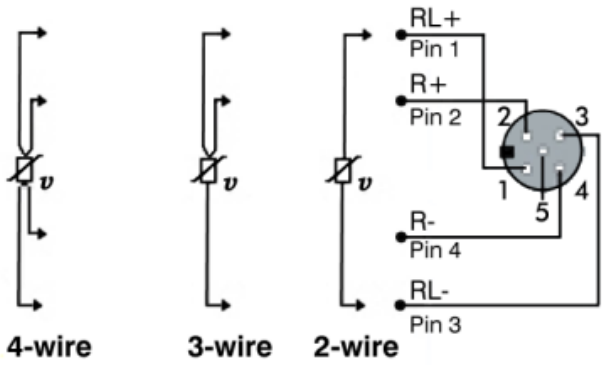

Fig. 12: Resistance measurement with a 4-wire, 3-wire and 2-wire connection technique

The box uses the following calculation rule

$$Y_{R1} = \frac{(X_1 + O_{V1})}{2^2} \cdot \frac{G_{V1}}{2^{14}}, Y_{R2} = \frac{(X_2 + O_{V2})}{2^2} \cdot \frac{G_{V2}}{2^{14}}$$

$$Y_R = Y_{R2} - (Y_{R1} - Y_{R2}) = 2Y_{R2} - Y_{R1}$$

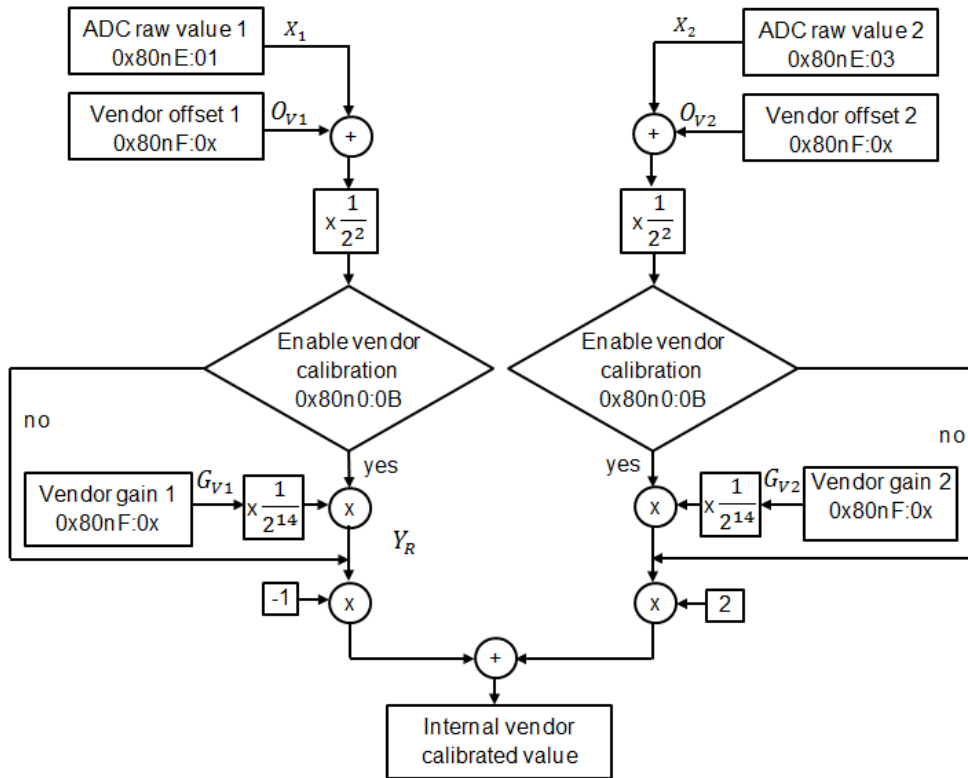

Fig. 13: Data flow: resistance measurement with a 3-wire connection technique

With the values:

	Index in the CoE directory with n: channel number with 0 ≤ n ≤ 3 (channel 1 - 4)	
X <sub>1</sub> : raw value of the 1 <sup>st</sup> measurement	0x80nE:01	
X <sub>2</sub> : raw value of the 2 <sup>nd</sup> measurement	0x80nE:03	
	Pt100	Pt1000
G <sub>V1</sub> : Vendor gain, 1 <sup>st</sup> measurement	0x80nF:04	0x80nF:0A
O <sub>V1</sub> : Vendor offset, 1 <sup>st</sup> measurement	0x80nF:03	0x80nF:09
G <sub>V2</sub> : Vendor gain, 2 <sup>nd</sup> measurement	0x80nF:02	0x80nF:08
O <sub>V2</sub> : Vendor offset, 2 <sup>nd</sup> measurement	0x80nF:01	0x80nF:07
Y <sub>R1</sub> : Output value in 1/256 Ω	0x80nE:02	
Y <sub>R2</sub> : Output value in 1/256 Ω	0x80nE:04	
Y <sub>R</sub> : Output value in 1/256 Ω		



**Overflow Y<sub>R1</sub> and Y<sub>R2</sub> after 16 bits**

These values are only for fault finding. The registers overflow after 16 bits, i.e. at 65536.

### 6.2.2 User calibration and linearization

- The calibrated measured value may also be modified by the user calibration values.
- The result of the resistance measurement is mapped onto a temperature value. The fundamental linearization function cannot be modified by the user.
- The user scaling is only included after the linearization.

The box uses the following calculation rule

$$Y_{int} = X_V \cdot \frac{G_U}{2^{14}} + O_U$$

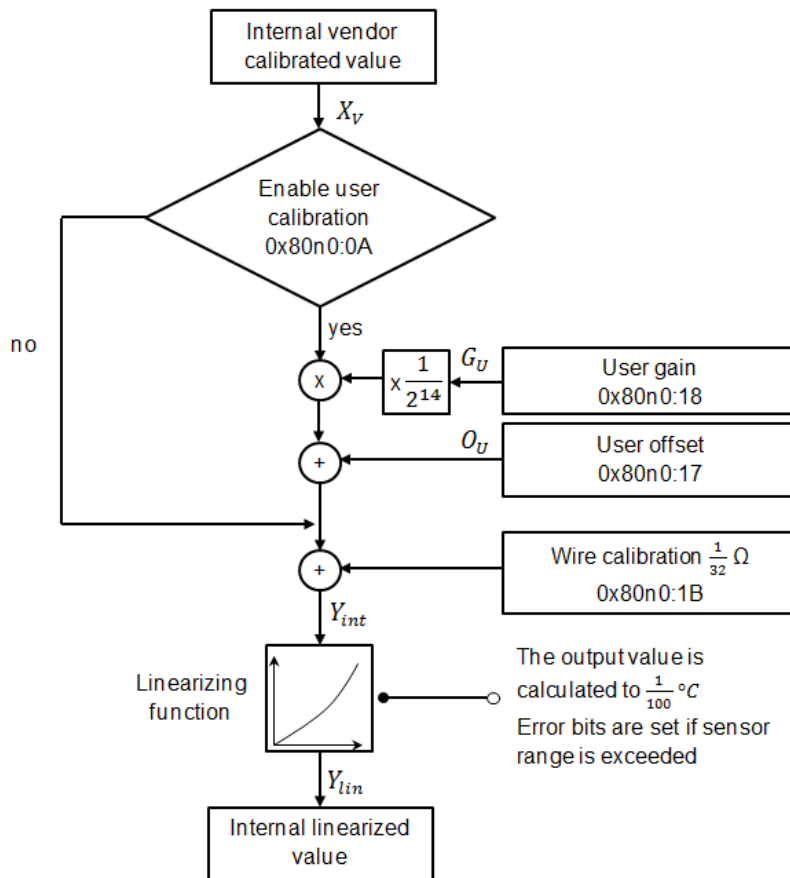

Fig. 14: Data flow: user compensation and linearization

With the values:

	Index in the CoE directory with n: channel number with 0 ≤ n ≤ 3 (channel 1 - 4)
X <sub>v</sub> : Output value of the vendor calibration	
G <sub>U</sub> : User Gain	0x80n0:18
O <sub>U</sub> : User Offset	0x80n0:17
Y <sub>int</sub> : Output value in 1/256 Ω prior to the linearization	

### 6.2.3 Scaling, limits and formatting

- Following the calculation of the resistance value, the scaling and the limit bits are evaluated.
- The result is formatted in accordance with the set presentation and copied into the process image.

The box uses the following calculation rule

$$Y = Y_{lin} \cdot \frac{G_S}{2^{16}} + O_S$$

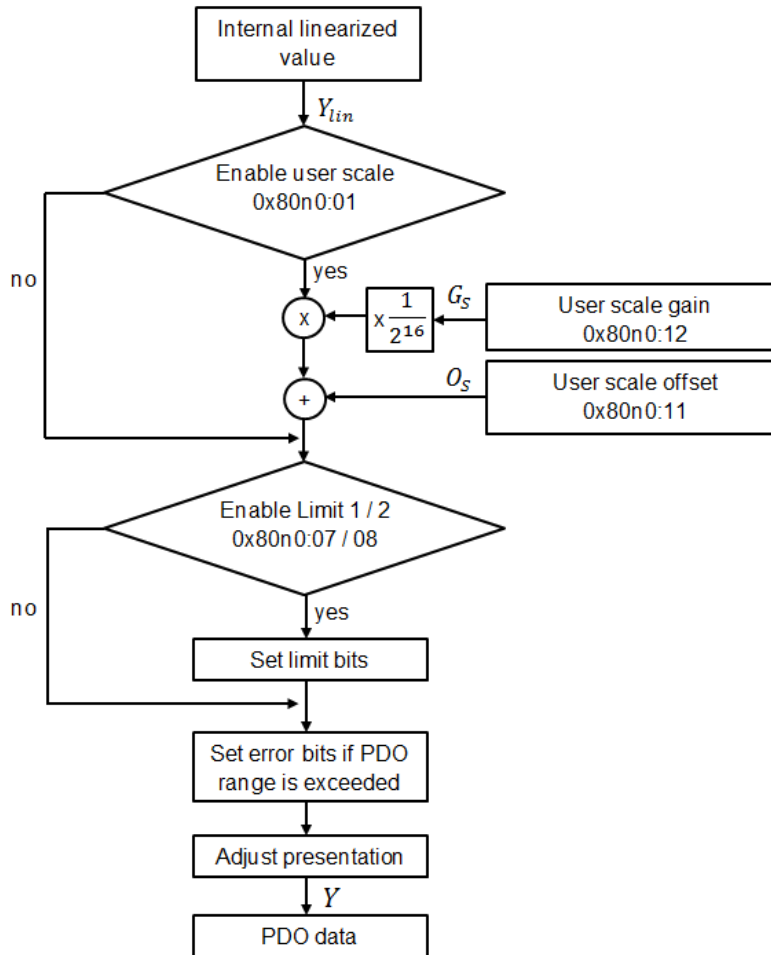

Fig. 15: Data flow: user scaling, limit evaluation, error bits and formatting

With the values:

	Index in the CoE directory with n: channel number with 0 ≤ n ≤ 3 (channel 1 - 4)
Y <sub>lin</sub> : Output value in 1/100 °C	
G <sub>S</sub> : User Scale Gain	0x80n0:12
O <sub>S</sub> : User Scale Offset	0x80n0:11
Y: Output value PDO	

## 6.2.4 Summary

Summary of the calculation rules:

Vendor calibration <b>2- and 4-wire</b> measurement	$Y_R = \frac{(X_1 + O_V)}{2^2} \cdot \frac{G_V}{2^{14}}$
Vendor calibration <b>3-wire</b> measurement	$Y_{R1} = \frac{(X_1 + O_{V1})}{2^2} \cdot \frac{G_{V1}}{2^{14}}, Y_{R2} = \frac{(X_2 + O_{V2})}{2^2} \cdot \frac{G_{V2}}{2^{14}}$ $Y_R = 2Y_{R2} - Y_{R1}$
User calibration and <u>linearization</u>	$Y_{int} = X_V \cdot \frac{G_U}{2^{14}} + O_U$
User scale, <u>limits</u> and presentation	$Y = Y_{lin} \cdot \frac{G_S}{2^{16}} + O_S$
Summary <b>2-, 4-wire</b> measurement	$Y = f_{pres} \left( \frac{G_S}{2^{16}} \cdot f_{lin} \left( \frac{(X_1 + O_V)}{2^2} \cdot \frac{G_V}{2^{14}} \cdot \frac{G_U}{2^{14}} + O_U \right) + O_S \right)$
Summary <b>3-wire</b> measurement	$Y = f_{pres} \left( \frac{G_S}{2^{16}} \cdot f_{lin} \left( (2Y_{R2} - Y_{R1}) \cdot \frac{G_V}{2^{14}} \cdot \frac{G_U}{2^{14}} + O_U \right) + O_S \right)$

With the values:

	Index in the CoE directory with n: channel number with $0 \leq n \leq 3$ (channel 1 - 4)			
X <sub>1</sub> : Raw value of the 1 <sup>st</sup> measurement	0x80nE:01			
X <sub>2</sub> : Raw value of the 2 <sup>nd</sup> measurement	0x80nE:03			
	<b>Pt100</b>		<b>Pt1000</b>	
	<b>2-wire</b>	<b>4-wire</b>	<b>2-wire</b>	<b>4-wire</b>
G <sub>v</sub> : Vendor Gain	0x80nF:04	0x80nF:06	0x80nF:0A	0x80nF:0C
O <sub>v</sub> : Vendor Offset	0x80nF:03	0x80nF:05	0x80nF:09	0x80nF:0B
	<b>3-wire</b>			
G <sub>v1</sub> : Vendor gain, 1 <sup>st</sup> measurement	0x80nF:04		0x80nF:0A	
O <sub>v1</sub> : Vendor offset, 1 <sup>st</sup> measurement	0x80nF:03		0x80nF:09	
G <sub>v2</sub> : Vendor gain, 2 <sup>nd</sup> measurement	0x80nF:02		0x80nF:08	
O <sub>v2</sub> : Vendor offset, 2 <sup>nd</sup> measurement	0x80nF:01		0x80nF:07	
G <sub>u</sub> : User Gain	0x80n0:18			
O <sub>u</sub> : User Scale Offset	0x80n0:17			
G <sub>s</sub> : User Scale Gain	0x80n0:12			
O <sub>s</sub> : User Scale Offset	0x80n0:11			
f <sub>lin</sub> : Function for mapping to the selected method of representation				
f <sub>pres</sub> : Linearization function				
Y <sub>R1</sub> : Output value in 1/256 Ω	0x80nE:02			
Y <sub>R2</sub> : Output value in 1/256 Ω	0x80nE:04			
Y: Output value PDO				



### Overflow Y<sub>R1</sub> and Y<sub>R2</sub> after 16 bits

These values are only for fault finding. The registers overflow after 16 bits, i.e. at 65536.

## 6.2.5 Two-point user calibration

The vendor calibration is to be deactivated via index (0x80n0:0B).

Up to FW version 07 the deactivation of the vendor calibration only results in the vendor gain being set to  $2^{14}$  (fixed-point representation for 1.0). The vendor offset remains unchanged and is still included. This results in the following with vendor calibration deactivated:

$$Y_{int} = (X + O_V) \cdot G_U \cdot \frac{1}{2^{16}} + O_U$$

$$Y_{int} = X \cdot G_U \cdot \frac{1}{2^{16}} + \underbrace{O_V \cdot G_U \cdot \frac{1}{2^{16}} + O_U}_{constant}$$

Since the last part of the term is constant, a user calibration can be performed despite the unavoidable influence of the vendor offset. The influence of the vendor offset can thereby be fully compensated. The following method is to be applied:

Carry out two reference measurements with  $Y_1(X_1)$  and  $Y_2(X_2)$ . Then the following applies:

$$g_f = \frac{X_2 - X_1}{Y_2 - Y_1} \quad (1)$$

$$G_U = g_f \cdot 2^{16} \quad (2)$$

$$O_U = X_1 - (Y_1 + O_V) \cdot g_f \quad (3)$$

$G_U$  and  $O_U$  are to be rounded to the nearest whole number and entered in index 0x80n0:18 and index 0x80n0:17.

X	Raw value (0x80nE:01)
$O_V$ :	Vendor Offset (index depends on the mode, see chapter <a href="#">Vendor calibration [► 49]</a> )
$G_U$ :	User Gain (0x80n0:18)
$O_U$ :	User Offset (0x80n0:17)
$g_f$ :	Gain as a floating value
$O_R$ :	Offset as a raw value
$X_n$ :	Measured raw value with reference measurement $n$
$Y_n$ :	Reference value in 1/256 $\Omega$
$Y_{int}$ :	Output value in 1/256 $\Omega$ prior to the linearization

### NOTICE

#### **$Y_n$ : Use of the raw value**

Since the resistance value in index 0x8xxE:02 overflows, the raw value in index 0x8xxE:01 is used for  $Y_n$ .



**6.2.5.1 Example**

Channel 1 is to be calibrated with two-wire connection at two points with 100 Ω and 350 Ω. The vendor offset for the 2-wire calibration is -2607 (taken from index 0x800F:03).

The following measured values are recorded:

100 Ω through precision resistor	$X_1 = 25600$ (1/256 Ω)
171125, read in index 0x800E:01	$Y_1 = 171125$
350 Ω through precision resistor	$X_2 = 89600$ (1/256 Ω)
592224, read in index 0x800E:01	$Y_2 = 592224$

With the equations (1) - (3):

$$g_f = \frac{X_2 - X_1}{Y_2 - Y_1} \quad (1)$$

$$G_U = g_f \cdot 2^{16} \quad (2)$$

$$O_U = X_1 - (Y_1 + O_V) \cdot g_f \quad (3)$$

the resulting values for  $g_f$ ,  $G_U$  and  $O_U$  are:

$$g_f = \frac{89600 - 25600}{592224 - 171125} = 0.15198326 \quad (1)$$

$$G_U = 0.15198326 \cdot 2^{16} = 9960.375114 \quad (2)$$

$$O_U = 25600 - (171125 + 2607) \cdot 0.15198326 = -11.915 \quad (3)$$

The indices accept only integer values. The following entries are to be made in the CoE:

- Index 0x8000:17 = -12
- Index 0x8000:18 = 9960

Subsequently the vendor calibration is to be deactivated (0x8000:0B) and the user calibration activated (0x8000:0A).

## 6.3 EP3204 - object overview

### **i** EtherCAT XML Device Description

The display matches that of the CoE objects from the EtherCAT XML Device Description. We recommend downloading the latest XML file from the download area of the Beckhoff website and installing it according to installation instructions.

Index (hex)	Name	Flags	Default value	
1000 [▶ 70]	Device type	RO	0x01401389 (20976521 <sub>dec</sub> )	
1008 [▶ 70]	Device name	RO	EPP3204-0002	
1009 [▶ 70]	Hardware version	RO	01	
100A [▶ 70]	Software version	RO	03	
1011:0 [▶ 64]	<b>Subindex</b>	Restore default parameters	RO	0x01 (1 <sub>dec</sub> )
	1011:01	SubIndex 001	RW	0x00000000 (0 <sub>dec</sub> )
1018:0 [▶ 70]	<b>Subindex</b>	Identity	RO	0x04 (4 <sub>dec</sub> )
	1018:01	Vendor ID	RO	0x00000002 (2 <sub>dec</sub> )
	1018:02	Product code	RO	0x0C844052 (209993810 <sub>dec</sub> )
	1018:03	Revision	RO	0x00120002 (1179650 <sub>dec</sub> )
	1018:04	Serial number	RO	0x00000000 (0 <sub>dec</sub> )
10F0:0 [▶ 70]	<b>Subindex</b>	Backup parameter handling	RO	0x01 (1 <sub>dec</sub> )
	10F0:01	Checksum	RO	0x00000000 (0 <sub>dec</sub> )
1A00:0 [▶ 70]	<b>Subindex</b>	RTD TxPDO-Map RTDInputs Ch.1	RO	0x0A (10 <sub>dec</sub> )
	1A00:01	SubIndex 001	RO	0x6000:01, 1
	1A00:02	SubIndex 002	RO	0x6000:02, 1
	1A00:03	SubIndex 003	RO	0x6000:03, 2
	1A00:04	SubIndex 004	RO	0x6000:05, 2
	1A00:05	SubIndex 005	RO	0x6000:07, 1
	1A00:06	SubIndex 006	RO	0x0000:00, 6
	1A00:07	SubIndex 007	RO	0x6000:0E, 1
	1A00:08	SubIndex 008	RO	0x1800:07, 1
	1A00:09	SubIndex 009	RO	0x1800:09, 1
	1A00:0A	SubIndex 010	RO	0x6000:11, 16
	1A01:0 [▶ 71]	<b>Subindex</b>	RTD TxPDO-Map RTDInputs Ch.2	RO
1A01:01		SubIndex 001	RO	0x6010:01, 1
1A01:02		SubIndex 002	RO	0x6010:02, 1
1A01:03		SubIndex 003	RO	0x6010:03, 2
1A01:04		SubIndex 004	RO	0x6010:05, 2
1A01:05		SubIndex 005	RO	0x6010:07, 1
1A01:06		SubIndex 006	RO	0x0000:00, 6
1A01:07		SubIndex 007	RO	0x6010:0E, 1
1A01:08		SubIndex 008	RO	0x1801:07, 1
1A01:09		SubIndex 009	RO	0x1801:09, 1
1A01:0A		SubIndex 010	RO	0x6010:11, 16
1A02:0 [▶ 71]		<b>Subindex</b>	RTD TxPDO-Map RTDInputs Ch.3	RO
	1A02:01	SubIndex 001	RO	0x6020:01, 1
	1A02:02	SubIndex 002	RO	0x6020:02, 1
	1A02:03	SubIndex 003	RO	0x6020:03, 2
	1A02:04	SubIndex 004	RO	0x6020:05, 2
	1A02:05	SubIndex 005	RO	0x6020:07, 1
	1A02:06	SubIndex 006	RO	0x0000:00, 6
	1A02:07	SubIndex 007	RO	0x6020:0E, 1
	1A02:08	SubIndex 008	RO	0x1802:07, 1
	1A02:09	SubIndex 009	RO	0x1802:09, 1
	1A02:0A	SubIndex 010	RO	0x6020:11, 16

Index (hex)		Name	Flags	Default value
1A03:0 [▶ 71]	<b>Subindex</b>	RTD TxPDO-Map RTDInputs Ch.4	RO	0x0A (10 <sub>dec</sub> )
	1A03:01	SubIndex 001	RO	0x6030:01, 1
	1A03:02	SubIndex 002	RO	0x6030:02, 1
	1A03:03	SubIndex 003	RO	0x6030:03, 2
	1A03:04	SubIndex 004	RO	0x6030:05, 2
	1A03:05	SubIndex 005	RO	0x6030:07, 1
	1A03:06	SubIndex 006	RO	0x0000:00, 6
	1A03:07	SubIndex 007	RO	0x6030:0E, 1
	1A03:08	SubIndex 008	RO	0x1803:07, 1
	1A03:09	SubIndex 009	RO	0x1803:09, 1
	1A03:0A	SubIndex 010	RO	0x6030:11, 16
1C00:0 [▶ 71]	<b>Subindex</b>	Sync manager type	RO	0x04 (4 <sub>dec</sub> )
	1C00:01	SubIndex 001	RO	0x01 (1 <sub>dec</sub> )
	1C00:02	SubIndex 002	RO	0x02 (2 <sub>dec</sub> )
	1C00:03	SubIndex 003	RO	0x03 (3 <sub>dec</sub> )
	1C00:04	SubIndex 004	RO	0x04 (4 <sub>dec</sub> )
1C12:0 [▶ 71]	<b>Subindex</b>	RxPDO assign	RW	0x00 (0 <sub>dec</sub> )
1C13:0 [▶ 72]	<b>Subindex</b>	TxPDO assign	RW	0x04 (4 <sub>dec</sub> )
	1C13:01	SubIndex 001	RW	0x1A00 (6656 <sub>dec</sub> )
	1C13:02	SubIndex 002	RW	0x1A01 (6657 <sub>dec</sub> )
	1C13:03	SubIndex 003	RW	0x1A02 (6658 <sub>dec</sub> )
	1C13:04	SubIndex 004	RW	0x1A03 (6659 <sub>dec</sub> )
1C33:0 [▶ 72]	<b>Subindex</b>	SM input parameter	RO	0x20 (32 <sub>dec</sub> )
	1C33:01	Sync mode	RW	0x0000 (0 <sub>dec</sub> )
	1C33:02	Cycle time	RW	0x000F4240 (1000000 <sub>dec</sub> )
	1C33:03	Shift time	RO	0x00000000 (0 <sub>dec</sub> )
	1C33:04	Sync modes supported	RO	0xC007 (49159 <sub>dec</sub> )
	1C33:05	Minimum cycle time	RO	0x00002710 (10000 <sub>dec</sub> )
	1C33:06	Calc and copy time	RO	0x00000000 (0 <sub>dec</sub> )
	1C33:07	Minimum delay time	RO	0x00000000 (0 <sub>dec</sub> )
	1C33:08	Command	RW	0x0000 (0 <sub>dec</sub> )
	1C33:09	Maximum Delay time	RO	0x00000000 (0 <sub>dec</sub> )
	1C33:0B	SM event missed counter	RO	0x0000 (0 <sub>dec</sub> )
	1C33:0C	Cycle exceeded counter	RO	0x0000 (0 <sub>dec</sub> )
	1C33:0D	Shift too short counter	RO	0x0000 (0 <sub>dec</sub> )
	1C33:20	Sync error	RO	0x00 (0 <sub>dec</sub> )
6000:0 [▶ 73]	<b>Subindex</b>	RTD Inputs Ch.1	RO	0x11 (17 <sub>dec</sub> )
	6000:01	Underrange	RO	0x00 (0 <sub>dec</sub> )
	6000:02	Overrange	RO	0x00 (0 <sub>dec</sub> )
	6000:03	Limit 1	RO	0x00 (0 <sub>dec</sub> )
	6000:05	Limit 2	RO	0x00 (0 <sub>dec</sub> )
	6000:07	Error	RO	0x00 (0 <sub>dec</sub> )
	6000:0E	Sync error	RO	0x00 (0 <sub>dec</sub> )
	6000:0F	TxPDO State	RO	0x00 (0 <sub>dec</sub> )
	6000:10	TxPDO Toggle	RO	0x00 (0 <sub>dec</sub> )
	6000:11	Value	RO	0x0000 (0 <sub>dec</sub> )
	6010:0 [▶ 73]	<b>Subindex</b>	RTD Inputs Ch.2	RO
6010:01		Underrange	RO	0x00 (0 <sub>dec</sub> )
6010:02		Overrange	RO	0x00 (0 <sub>dec</sub> )
6010:03		Limit 1	RO	0x00 (0 <sub>dec</sub> )
6010:05		Limit 2	RO	0x00 (0 <sub>dec</sub> )
6010:07		Error	RO	0x00 (0 <sub>dec</sub> )
6010:0E		Sync error	RO	0x00 (0 <sub>dec</sub> )
6010:0F		TxPDO State	RO	0x00 (0 <sub>dec</sub> )
6010:10		TxPDO Toggle	RO	0x00 (0 <sub>dec</sub> )
6010:11		Value	RO	0x0000 (0 <sub>dec</sub> )

Index (hex)		Name	Flags	Default value
6020:0 [▶ 74]	<b>Subindex</b>	RTD Inputs Ch.3	RO	0x11 (17 <sub>dec</sub> )
	6020:01	Underrange	RO	0x00 (0 <sub>dec</sub> )
	6020:02	Overrange	RO	0x00 (0 <sub>dec</sub> )
	6020:03	Limit 1	RO	0x00 (0 <sub>dec</sub> )
	6020:05	Limit 2	RO	0x00 (0 <sub>dec</sub> )
	6020:07	Error	RO	0x00 (0 <sub>dec</sub> )
	6020:0E	Sync error	RO	0x00 (0 <sub>dec</sub> )
	6020:0F	TxPDO State	RO	0x00 (0 <sub>dec</sub> )
	6020:10	TxPDO Toggle	RO	0x00 (0 <sub>dec</sub> )
6020:11	Value	RO	0x0000 (0 <sub>dec</sub> )	
6030:0 [▶ 74]	<b>Subindex</b>	RTD Inputs Ch.4	RO	0x11 (17 <sub>dec</sub> )
	6030:01	Underrange	RO	0x00 (0 <sub>dec</sub> )
	6030:02	Overrange	RO	0x00 (0 <sub>dec</sub> )
	6030:03	Limit 1	RO	0x00 (0 <sub>dec</sub> )
	6030:05	Limit 2	RO	0x00 (0 <sub>dec</sub> )
	6030:07	Error	RO	0x00 (0 <sub>dec</sub> )
	6030:0E	Sync error	RO	0x00 (0 <sub>dec</sub> )
	6030:0F	TxPDO State	RO	0x00 (0 <sub>dec</sub> )
	6030:10	TxPDO Toggle	RO	0x00 (0 <sub>dec</sub> )
6030:11	Value	RO	0x0000 (0 <sub>dec</sub> )	
8000:0 [▶ 65]	<b>Subindex</b>	RTD Settings Ch.1	RW	0x1B (27 <sub>dec</sub> )
	8000:01	Enable user scale	RW	0x00 (0 <sub>dec</sub> )
	8000:02	Presentation	RW	0x00 (0 <sub>dec</sub> )
	8000:05	Siemens bits	RW	0x00 (0 <sub>dec</sub> )
	8000:06	Enable filter	RW	0x00 (0 <sub>dec</sub> )
	8000:07	Enable limit 1	RW	0x00 (0 <sub>dec</sub> )
	8000:08	Enable limit 2	RW	0x00 (0 <sub>dec</sub> )
	8000:0A	Enable user calibration	RW	0x00 (0 <sub>dec</sub> )
	8000:0B	Enable vendor calibration	RW	0x01 (1 <sub>dec</sub> )
	8000:0E	Swap limit bits	RW	0x00 (0 <sub>dec</sub> )
	8000:11	User scale offset	RW	0x0000 (0 <sub>dec</sub> )
	8000:12	User scale gain	RW	0x00010000 (65536 <sub>dec</sub> )
	8000:13	Limit 1	RW	0x0000 (0 <sub>dec</sub> )
	8000:14	Limit 2	RW	0x0000 (0 <sub>dec</sub> )
	8000:15	Filter settings	RW	0x0000 (0 <sub>dec</sub> )
	8000:16	Calibration interval	RW	0x0000 (0 <sub>dec</sub> )
	8000:17	User calibration offset	RW	0x0000 (0 <sub>dec</sub> )
	8000:18	User calibration gain	RW	0x4000 (16384 <sub>dec</sub> )
	8000:19	RTD element	RW	0x0000 (0 <sub>dec</sub> )
8000:1A	Connection technology	RW	0x0000 (0 <sub>dec</sub> )	
8000:1B	Wire calibration 1/32 Ohm	RW	0x0000 (0 <sub>dec</sub> )	
800E:0 [▶ 75]	<b>Subindex</b>	RTD Internal data Ch.1	RO	0x04 (4 <sub>dec</sub> )
	800E:01	ADC raw value 1	RO	0x00000000 (0 <sub>dec</sub> )
	800E:02	Resistor 1	RO	0x0000 (0 <sub>dec</sub> )
	800E:03	ADC raw value 2	RO	0x00000000 (0 <sub>dec</sub> )
	800E:04	Resistor 2	RO	0x0000 (0 <sub>dec</sub> )
800F:0 [▶ 75]	<b>Subindex</b>	RTD Vendor data Ch.1	RW	0x07 (7 <sub>dec</sub> )
	800F:01	Calibration offset 3-wire	RW	0x0000 (0 <sub>dec</sub> )
	800F:02	Calibration gain 3-wire	RW	0x4000 (16384 <sub>dec</sub> )
	800F:03	Calibration offset 2-wire	RW	0x0000 (0 <sub>dec</sub> )
	800F:04	Calibration gain 2-wire	RW	0x4000 (16384 <sub>dec</sub> )
	800F:05	Calibration offset 4-wire	RW	0x0000 (0 <sub>dec</sub> )
	800F:06	Calibration gain 4-wire	RW	0x4000 (16384 <sub>dec</sub> )
800F:07	PGA Gain Correction	RW	0x0000 (0 <sub>dec</sub> )	

Index (hex)		Name	Flags	Default value
8010:0 [▶ 66]	<b>Subindex</b>	RTD Settings Ch.2	RW	0x1B (27 <sub>dec</sub> )
	8010:01	Enable user scale	RW	0x00 (0 <sub>dec</sub> )
	8010:02	Presentation	RW	0x00 (0 <sub>dec</sub> )
	8010:05	Siemens bits	RW	0x00 (0 <sub>dec</sub> )
	8010:06	Enable filter	RW	0x00 (0 <sub>dec</sub> )
	8010:07	Enable limit 1	RW	0x00 (0 <sub>dec</sub> )
	8010:08	Enable limit 2	RW	0x00 (0 <sub>dec</sub> )
	8010:0A	Enable user calibration	RW	0x00 (0 <sub>dec</sub> )
	8010:0B	Enable vendor calibration	RW	0x01 (1 <sub>dec</sub> )
	8010:0E	Swap limit bits	RW	0x00 (0 <sub>dec</sub> )
	8010:11	User scale offset	RW	0x0000 (0 <sub>dec</sub> )
	8010:12	User scale gain	RW	0x00010000 (65536 <sub>dec</sub> )
	8010:13	Limit 1	RW	0x0000 (0 <sub>dec</sub> )
	8010:14	Limit 2	RW	0x0000 (0 <sub>dec</sub> )
	8010:15	Filter settings	RW	0x0000 (0 <sub>dec</sub> )
	8010:16	Calibration interval	RW	0x0000 (0 <sub>dec</sub> )
	8010:17	User calibration offset	RW	0x0000 (0 <sub>dec</sub> )
	8010:18	User calibration gain	RW	0x4000 (16384 <sub>dec</sub> )
	8010:19	RTD element	RW	0x0000 (0 <sub>dec</sub> )
	8010:1A	Connection technology	RW	0x0000 (0 <sub>dec</sub> )
8010:1B	Wire calibration 1/32 Ohm	RW	0x0000 (0 <sub>dec</sub> )	
801E:0 [▶ 75]	<b>Subindex</b>	RTD Internal data Ch.2	RO	0x04 (4 <sub>dec</sub> )
	801E:01	ADC raw value 1	RO	0x00000000 (0 <sub>dec</sub> )
	801E:02	Resistor 1	RO	0x0000 (0 <sub>dec</sub> )
	801E:03	ADC raw value 2	RO	0x00000000 (0 <sub>dec</sub> )
	801E:04	Resistor 2	RO	0x0000 (0 <sub>dec</sub> )
801F [▶ 75]	<b>Subindex</b>	RTD Vendor data Ch.2	RW	0x07 (7 <sub>dec</sub> )
	801F:01	Calibration offset 3-wire	RW	0x0000 (0 <sub>dec</sub> )
	801F:02	Calibration gain 3-wire	RW	0x4000 (16384 <sub>dec</sub> )
	801F:03	Calibration offset 2-wire	RW	0x0000 (0 <sub>dec</sub> )
	801F:04	Calibration gain 2-wire	RW	0x4000 (16384 <sub>dec</sub> )
	801F:05	Calibration offset 4-wire	RW	0x0000 (0 <sub>dec</sub> )
	801F:06	Calibration gain 4-wire	RW	0x4000 (16384 <sub>dec</sub> )
	801F:07	PGA Gain Correction	RW	0x0000 (0 <sub>dec</sub> )
8020:0 [▶ 67]	<b>Subindex</b>	RTD Settings Ch.3	RW	0x1B (27 <sub>dec</sub> )
	8020:01	Enable user scale	RW	0x00 (0 <sub>dec</sub> )
	8020:02	Presentation	RW	0x00 (0 <sub>dec</sub> )
	8020:05	Siemens bits	RW	0x00 (0 <sub>dec</sub> )
	8020:06	Enable filter	RW	0x00 (0 <sub>dec</sub> )
	8020:07	Enable limit 1	RW	0x00 (0 <sub>dec</sub> )
	8020:08	Enable limit 2	RW	0x00 (0 <sub>dec</sub> )
	8020:0A	Enable user calibration	RW	0x00 (0 <sub>dec</sub> )
	8020:0B	Enable vendor calibration	RW	0x01 (1 <sub>dec</sub> )
	8020:0E	Swap limit bits	RW	0x00 (0 <sub>dec</sub> )
	8020:11	User scale offset	RW	0x0000 (0 <sub>dec</sub> )
	8020:12	User scale gain	RW	0x00010000 (65536 <sub>dec</sub> )
	8020:13	Limit 1	RW	0x0000 (0 <sub>dec</sub> )
	8020:14	Limit 2	RW	0x0000 (0 <sub>dec</sub> )
	8020:15	Filter settings	RW	0x0000 (0 <sub>dec</sub> )
	8020:16	Calibration interval	RW	0x0000 (0 <sub>dec</sub> )
	8020:17	User calibration offset	RW	0x0000 (0 <sub>dec</sub> )
	8020:18	User calibration gain	RW	0x4000 (16384 <sub>dec</sub> )
	8020:19	RTD element	RW	0x0000 (0 <sub>dec</sub> )
	8020:1A	Connection technology	RW	0x0000 (0 <sub>dec</sub> )
8020:1B	Wire calibration 1/32 Ohm	RW	0x0000 (0 <sub>dec</sub> )	

Index (hex)		Name	Flags	Default value
802E:0 ▶ 76]	<b>Subindex</b>	RTD Internal data Ch.3	RO	0x04 (4 <sub>dec</sub> )
	802E:01	ADC raw value 1	RO	0x00000000 (0 <sub>dec</sub> )
	802E:02	Resistor 1	RO	0x0000 (0 <sub>dec</sub> )
	802E:03	ADC raw value 2	RO	0x00000000 (0 <sub>dec</sub> )
	802E:04	Resistor 2	RO	0x0000 (0 <sub>dec</sub> )
802F:0 ▶ 76]	<b>Subindex</b>	RTD Vendor data Ch.3	RW	0x07 (7 <sub>dec</sub> )
	802F:01	Calibration offset 3-wire	RW	0x0000 (0 <sub>dec</sub> )
	802F:02	Calibration gain 3-wire	RW	0x4000 (16384 <sub>dec</sub> )
	802F:03	Calibration offset 2-wire	RW	0x0000 (0 <sub>dec</sub> )
	802F:04	Calibration gain 2-wire	RW	0x4000 (16384 <sub>dec</sub> )
	802F:05	Calibration offset 4-wire	RW	0x0000 (0 <sub>dec</sub> )
	802F:06	Calibration gain 4-wire	RW	0x4000 (16384 <sub>dec</sub> )
	802F:07	PGA Gain Correction	RW	0x0000 (0 <sub>dec</sub> )
8030:0 ▶ 68]	<b>Subindex</b>	RTD Settings Ch.4	RW	0x1B (27 <sub>dec</sub> )
	8030:01	Enable user scale	RW	0x00 (0 <sub>dec</sub> )
	8030:02	Presentation	RW	0x00 (0 <sub>dec</sub> )
	8030:05	Siemens bits	RW	0x00 (0 <sub>dec</sub> )
	8030:06	Enable filter	RW	0x00 (0 <sub>dec</sub> )
	8030:07	Enable limit 1	RW	0x00 (0 <sub>dec</sub> )
	8030:08	Enable limit 2	RW	0x00 (0 <sub>dec</sub> )
	8030:0A	Enable user calibration	RW	0x00 (0 <sub>dec</sub> )
	8030:0B	Enable vendor calibration	RW	0x01 (1 <sub>dec</sub> )
	8030:0E	Swap limit bits	RW	0x00 (0 <sub>dec</sub> )
	8030:11	User scale offset	RW	0x0000 (0 <sub>dec</sub> )
	8030:12	User scale gain	RW	0x00010000 (65536 <sub>dec</sub> )
	8030:13	Limit 1	RW	0x0000 (0 <sub>dec</sub> )
	8030:14	Limit 2	RW	0x0000 (0 <sub>dec</sub> )
	8030:15	Filter settings	RW	0x0000 (0 <sub>dec</sub> )
	8030:16	Calibration interval	RW	0x0000 (0 <sub>dec</sub> )
	8030:17	User calibration offset	RW	0x0000 (0 <sub>dec</sub> )
	8030:18	User calibration gain	RW	0x4000 (16384 <sub>dec</sub> )
	8030:19	RTD element	RW	0x0000 (0 <sub>dec</sub> )
	8030:1A	Connection technology	RW	0x0000 (0 <sub>dec</sub> )
8030:1B	Wire calibration 1/32 Ohm	RW	0x0000 (0 <sub>dec</sub> )	
803E:0 ▶ 76]	<b>Subindex</b>	RTD Internal data Ch.4	RO	0x04 (4 <sub>dec</sub> )
	803E:01	ADC raw value 1	RO	0x00000000 (0 <sub>dec</sub> )
	803E:02	Resistor 1	RO	0x0000 (0 <sub>dec</sub> )
	803E:03	ADC raw value 2	RO	0x00000000 (0 <sub>dec</sub> )
	803E:04	Resistor 2	RO	0x0000 (0 <sub>dec</sub> )
803F:0 ▶ 76]	<b>Subindex</b>	RTD Vendor data Ch.4	RW	0x07 (7 <sub>dec</sub> )
	803F:01	Calibration offset 3-wire	RW	0x0000 (0 <sub>dec</sub> )
	803F:02	Calibration gain 3-wire	RW	0x4000 (16384 <sub>dec</sub> )
	803F:03	Calibration offset 2-wire	RW	0x0000 (0 <sub>dec</sub> )
	803F:04	Calibration gain 2-wire	RW	0x4000 (16384 <sub>dec</sub> )
	803F:05	Calibration offset 4-wire	RW	0x0000 (0 <sub>dec</sub> )
	803F:06	Calibration gain 4-wire	RW	0x4000 (16384 <sub>dec</sub> )
	803F:07	PGA Gain Correction	RW	0x0000 (0 <sub>dec</sub> )
F000:0 ▶ 77]	<b>Subindex</b>	Modular device profile	RO	0x02 (2 <sub>dec</sub> )
	F000:01	Module index distance	RO	0x0010 (16 <sub>dec</sub> )
	F000:02	Maximum number of modules	RO	0x0004 (4 <sub>dec</sub> )
F008 ▶ 77]		Code word	RW	0x00000000 (0 <sub>dec</sub> )
F010:0 ▶ 77]	<b>Subindex</b>	Module list	RW	0x04 (4 <sub>dec</sub> )
	F010:01	SubIndex 001	RW	0x00000140 (320 <sub>dec</sub> )
	F010:02	SubIndex 002	RW	0x00000140 (320 <sub>dec</sub> )
	F010:03	SubIndex 003	RW	0x00000140 (320 <sub>dec</sub> )
	F010:04	SubIndex 004	RW	0x00000140 (320 <sub>dec</sub> )

Index (hex)		Name	Flags	Default value
F080:0 [▶ 77]	<b>Subindex</b>	Channel Enable	RO	0x04 (4 <sub>dec</sub> )
	F080:01	SubIndex 001	RW	0xFF (255 <sub>dec</sub> )
	F080:02	SubIndex 002	RW	0xFF (255 <sub>dec</sub> )
	F080:03	SubIndex 003	RW	0xFF (255 <sub>dec</sub> )
	F080:04	SubIndex 004	RW	0xFF (255 <sub>dec</sub> )

**Key**

Flags:

RO (Read Only): this object can be read only

RW (Read/Write): this object can be read and written to

## 6.4 EP3204 - object description and parameterization

### ● **Parameterization**

You can parameterize the box via the "CoE - Online" tab in TwinCAT.

### ● **EtherCAT XML Device Description**

The presentation matches that of the EtherCAT XML Device Description.

Recommendation: download the latest XML file from <https://www.beckhoff.com/> and install it according to the installation instructions.

### Introduction

The CoE overview contains objects for different intended applications:

- Objects required for [parameterization \[▶ 64\]](#) during commissioning
- [Objects intended for regular operation \[▶ 69\]](#), e.g. through ADS access.
- Objects for indicating [internal settings \[▶ 70\]](#) (may be fixed)
- Further [profile-specific objects \[▶ 73\]](#) indicating inputs, outputs and status information

The following section first describes the objects required for normal operation, followed by a complete overview of missing objects.

### 6.4.1 Objects to be parameterized during commissioning

#### Index 1011: Restore default parameters

Index (hex)	Name	Meaning	Data type	Flags	Default
1011:0	Restore default parameters	Restore default parameters	UINT8	RO	0x01 (1 <sub>dec</sub> )
1011:01	SubIndex 001	If this object is set to " <b>0x64616F6C</b> " in the set value dialog, all backup objects are reset to their delivery state.	UINT32	RW	0x00000000 (0 <sub>dec</sub> )



**Index 8000: RTD Settings Ch.1**

Index (hex)	Name	Meaning	Data type	Flags	Default
8000:0	RTD Settings Ch.1	Maximum subindex	UINT8	RO	0x1B (27 <sub>dec</sub> )
8000:01	Enable user scale	Activates user scaling	BOOLEAN	RW	0x00 (0 <sub>dec</sub> )
8000:02	Presentation	Presentation of the measured value	BIT3	RW	0x00 (0 <sub>dec</sub> )
		0 Signed, in two's complement			
		1 Most significant bit as sign			
		2 High-resolution (1/100 °C steps)			
8000:05	Siemens bits	The S5 bits are displayed in the three low-order bits	BOOLEAN	RW	0x00 (0 <sub>dec</sub> )
8000:06	Enable filter	Enable filter, which makes PLC-cycle-synchronous data exchange unnecessary	BOOLEAN	RW	0x00 (0 <sub>dec</sub> )
8000:07	Enable limit 1	Activates limit check for limit 1	BOOLEAN	RW	0x00 (0 <sub>dec</sub> )
8000:08	Enable limit 2	Activates limit check for limit 2	BOOLEAN	RW	0x00 (0 <sub>dec</sub> )
8000:0A	Enable user calibration	Activates user calibration	BOOLEAN	RW	0x00 (0 <sub>dec</sub> )
8000:0B	Enable vendor calibration	Activates vendor calibration	BOOLEAN	RW	0x01 (1 <sub>dec</sub> )
8000:0E	Swap limit bits	Swaps the two limit bits, in order to achieve compatibility with older hardware versions.	BOOLEAN	RW	0x00 (0 <sub>dec</sub> )
8000:11	User scale offset	User scaling offset	INT16	RW	0x0000 (0 <sub>dec</sub> )
8000:12	User scale gain	Gain of the user scaling	INT32	RW	0x00010000 (65536 <sub>dec</sub> )
8000:13	Limit 1	Value for limit 1	INT16	RW	0x0000 (0 <sub>dec</sub> )
8000:14	Limit 2	Value for limit 2	INT16	RW	0x0000 (0 <sub>dec</sub> )
8000:15	Filter settings	Filter settings	UINT16	RW	0x0000 (0 <sub>dec</sub> )
		0 50 Hz			
		1 60 Hz			
		2 100 Hz			
		3 500 Hz			
		4 1 kHz			
		5 2 kHz			
		6 3.75 kHz			
		7 7.5 kHz			
		8 15 kHz			
		9 30 kHz			
		10 5 Hz			
11 10 Hz					
8000:16	Calibration interval	reserved	UINT16	RW	0x0000 (0 <sub>dec</sub> )
8000:17	User calibration offset	User calibration offset	INT16	RW	0x0000 (0 <sub>dec</sub> )
8000:18	User calibration gain	Gain of the user calibration	UINT16	RW	0x4000 (16384 <sub>dec</sub> )
8000:19	RTD element	Sensor type	UINT16	RW	0x0000 (0 <sub>dec</sub> )
		0 Pt100			
		1 Ni100			
		2 Pt1000			
		3 Pt500			
		4 Pt200			
		5 Ni1000			
		6 Ni1000 (Siemens)			
		7 Ni120			
		8 Resistance measurement with 1/16 ohm resolution			
9 Resistance measurement with 1/64 ohm resolution					

## Index 8000: RTD Settings Ch.1

Index (hex)	Name	Meaning	Data type	Flags	Default	
8000:1A	Connection technology	Connection technology:	UINT16	RW	0x0000 (0 <sub>dec</sub> )	
		0				2-wire
		1				3-wire
		2				4-wire
3	No sensor connected (only supported by hardware version 00): This setting skips the whole measurement, thus speeding up the data acquisition for the other channels. The green status LED of the respective channel remains lit. The error bit of a deactivated channel is canceled and no longer set.					
8000:1B	Wire calibration 1/32 Ohm	Only for 2-wire measurements: contains the resistance of the supply line for the temperature sensor (in 1/32 ohm).	INT16	RW	0x0000 (0 <sub>dec</sub> )	

## Index 8010: RTD Settings Ch.2

Index (hex)	Name	Meaning	Data type	Flags	Default	
8010:0	RTD Settings Ch.2	Maximum subindex	UINT8	RO	0x1B (27 <sub>dec</sub> )	
8010:01	Enable user scale	Activates user scaling	BOOLEAN	RW	0x00 (0 <sub>dec</sub> )	
8010:02	Presentation	Presentation of the measured value	BIT3	RW	0x00 (0 <sub>dec</sub> )	
		0				Signed, in two's complement
		1				Most significant bit as sign
2	High-resolution (1/100 °C steps)					
8010:05	Siemens bits	The S5 bits are displayed in the three low-order bits	BOOLEAN	RW	0x00 (0 <sub>dec</sub> )	
8010:06	Enable filter	Enable filter, which makes PLC-cycle-synchronous data exchange unnecessary	BOOLEAN	RW	0x00 (0 <sub>dec</sub> )	
8010:07	Enable limit 1	Activates limit check for limit 1	BOOLEAN	RW	0x00 (0 <sub>dec</sub> )	
8010:08	Enable limit 2	Activates limit check for limit 2	BOOLEAN	RW	0x00 (0 <sub>dec</sub> )	
8010:0A	Enable user calibration	Activates user calibration	BOOLEAN	RW	0x00 (0 <sub>dec</sub> )	
8010:0B	Enable vendor calibration	Activates manufacturer calibration	BOOLEAN	RW	0x01 (1 <sub>dec</sub> )	
8010:0E	Swap limit bits	Swaps the two limit bits, in order to achieve compatibility with older hardware versions.	BOOLEAN	RW	0x00 (0 <sub>dec</sub> )	
8010:11	User scale offset	User scaling offset	INT16	RW	0x0000 (0 <sub>dec</sub> )	
8010:12	User scale gain	Gain of the user scaling	INT32	RW	0x00010000 (65536 <sub>dec</sub> )	
8010:13	Limit 1	Value for limit 1	INT16	RW	0x0000 (0 <sub>dec</sub> )	
8010:14	Limit 2	Value for limit 2	INT16	RW	0x0000 (0 <sub>dec</sub> )	
8010:15	Filter settings	Filter settings	UINT16	RW	0x0000 (0 <sub>dec</sub> )	
		0				50 Hz
		1				60 Hz
		2				100 Hz
		3				500 Hz
		4				1 kHz,
		5				2 kHz
		6				3.75 kHz
		7				7.5 kHz
		8				15 kHz
		9				30 kHz
		10				5 Hz
11	10 Hz					
8010:16	Calibration interval	reserved	UINT16	RW	0x0000 (0 <sub>dec</sub> )	
8010:17	User calibration offset	User calibration offset	INT16	RW	0x0000 (0 <sub>dec</sub> )	
8010:18	User calibration gain	Gain of the user calibration	UINT16	RW	0x4000 (16384 <sub>dec</sub> )	

**Index 8010: RTD Settings Ch.2**

Index (hex)	Name	Meaning	Data type	Flags	Default	
8010:19	RTD element	Sensor type	UINT16	RW	0x0000 (0 <sub>dec</sub> )	
		0				Pt100
		1				Ni100
		2				Pt1000
		3				Pt500
		4				Pt200
		5				Ni1000
		6				Ni1000 (Siemens)
		7				Ni120
		8				Resistance measurement with 1/16 ohm resolution
9	Resistance measurement with 1/64 ohm resolution					
8010:1A	Connection technology	Connection technology:	UINT16	RW	0x0000 (0 <sub>dec</sub> )	
		0				2-wire
		1				3-wire
		2				4-wire
3	No sensor connected (only supported by hardware version 00): This setting skips the whole measurement, thus speeding up the data acquisition for the other channels. The green status LED of the respective channel remains lit. The error bit of a deactivated channel is cancelled and no longer set.					
8010:1B	Wire calibration 1/32 Ohm	Only for 2-wire measurements: contains the resistance of the supply line for the temperature sensor (in 1/32 ohm).	INT16	RW	0x0000 (0 <sub>dec</sub> )	

**Index 8020: RTD Settings Ch.3**

Index (hex)	Name	Meaning	Data type	Flags	Default	
8020:0	RTD Settings Ch.3	Maximum subindex	UINT8	RO	0x1B (27 <sub>dec</sub> )	
8020:01	Enable user scale	Activates user scaling	BOOLEAN	RW	0x00 (0 <sub>dec</sub> )	
8020:02	Presentation	Presentation of the measured value	BIT3	RW	0x00 (0 <sub>dec</sub> )	
		0				Signed, in two's complement
		1				Most significant bit as sign
2	High-resolution (1/100 °C steps)					
8020:05	Siemens bits	The S5 bits are displayed in the three low-order bits	BOOLEAN	RW	0x00 (0 <sub>dec</sub> )	
8020:06	Enable filter	Enable filter, which makes PLC-cycle-synchronous data exchange unnecessary	BOOLEAN	RW	0x00 (0 <sub>dec</sub> )	
8020:07	Enable limit 1	Activates limit check for limit 1	BOOLEAN	RW	0x00 (0 <sub>dec</sub> )	
8020:08	Enable limit 2	Activates limit check for limit 2	BOOLEAN	RW	0x00 (0 <sub>dec</sub> )	
8020:0A	Enable user calibration	Activates user calibration	BOOLEAN	RW	0x00 (0 <sub>dec</sub> )	
8020:0B	Enable vendor calibration	Activates vendor calibration	BOOLEAN	RW	0x01 (1 <sub>dec</sub> )	
8020:0E	Swap limit bits	Swaps the two limit bits, in order to achieve compatibility with older hardware versions.	BOOLEAN	RW	0x00 (0 <sub>dec</sub> )	
8020:11	User scale offset	User scaling offset	INT16	RW	0x0000 (0 <sub>dec</sub> )	
8020:12	User scale gain	Gain of the user scaling	INT32	RW	0x00010000 (65536 <sub>dec</sub> )	
8020:13	Limit 1	Value for limit 1	INT16	RW	0x0000 (0 <sub>dec</sub> )	
8020:14	Limit 2	Value for limit 2	INT16	RW	0x0000 (0 <sub>dec</sub> )	

## Index 8020: RTD Settings Ch.3

Index (hex)	Name	Meaning	Data type	Flags	Default	
8020:15	Filter settings	Filter settings	UINT16	RW	0x0000 (0 <sub>dec</sub> )	
		0				50 Hz
		1				60 Hz
		2				100 Hz
		3				500 Hz
		4				1 kHz,
		5				2 kHz
		6				3.75 kHz
		7				7.5 kHz
		8				15 kHz
		9				30 kHz
		10				5 Hz
11	10 Hz					
8020:16	Calibration interval	reserved	UINT16	RW	0x0000 (0 <sub>dec</sub> )	
8020:17	User calibration offset	User calibration offset	INT16	RW	0x0000 (0 <sub>dec</sub> )	
8020:18	User calibration gain	Gain of the user calibration	UINT16	RW	0x4000 (16384 <sub>dec</sub> )	
8020:19	RTD element	Sensor type	UINT16	RW	0x0000 (0 <sub>dec</sub> )	
		0				Pt100
		1				Ni100
		2				Pt1000
		3				Pt500
		4				Pt200
		5				Ni1000
		6				Ni1000 (Siemens)
		7				Ni120
		8				Resistance measurement with 1/16 ohm resolution
9	Resistance measurement with 1/64 ohm resolution					
8020:1A	Connection technology	Connection technology:	UINT16	RW	0x0000 (0 <sub>dec</sub> )	
		0				2-wire
		1				3-wire
		2				4-wire
		3				No sensor connected (only supported by hardware version 00): This setting skips the whole measurement, thus speeding up the data acquisition for the other channels. The green status LED of the respective channel remains lit. The error bit of a deactivated channel is canceled and no longer set.
8020:1B	Wire calibration 1/32 Ohm	Only for 2-wire measurements: contains the resistance of the supply line for the temperature sensor (in 1/32 ohm).	INT16	RW	0x0000 (0 <sub>dec</sub> )	

## Index 8030: RTD Settings Ch.4

Index (hex)	Name	Meaning	Data type	Flags	Default	
8030:0	RTD Settings Ch.4	Maximum subindex	UINT8	RO	0x1B (27 <sub>dec</sub> )	
8030:01	Enable user scale	Activates user scaling	BOOLEAN	RW	0x00 (0 <sub>dec</sub> )	
8030:02	Presentation	Presentation of the measured value	BIT3	RW	0x00 (0 <sub>dec</sub> )	
		0				Signed, in two's complement
		1				Most significant bit as sign
2	High-resolution (1/100 °C steps)					
8030:05	Siemens bits	The S5 bits are displayed in the three low-order bits	BOOLEAN	RW	0x00 (0 <sub>dec</sub> )	
8030:06	Enable filter	Enable filter, which makes PLC-cycle-synchronous data exchange unnecessary	BOOLEAN	RW	0x00 (0 <sub>dec</sub> )	
8030:07	Enable limit 1	Activates limit check for limit 1	BOOLEAN	RW	0x00 (0 <sub>dec</sub> )	
8030:08	Enable limit 2	Activates limit check for limit 2	BOOLEAN	RW	0x00 (0 <sub>dec</sub> )	

**Index 8030: RTD Settings Ch.4**

Index (hex)	Name	Meaning	Data type	Flags	Default
8030:0A	Enable user calibration	Activates user calibration	BOOLEAN	RW	0x00 (0 <sub>dec</sub> )
8030:0B	Enable vendor calibration	Activates vendor calibration	BOOLEAN	RW	0x01 (1 <sub>dec</sub> )
8030:0E	Swap limit bits	Swaps the two limit bits, in order to achieve compatibility with older hardware versions.	BOOLEAN	RW	0x00 (0 <sub>dec</sub> )
8030:11	User scale offset	User scaling offset	INT16	RW	0x0000 (0 <sub>dec</sub> )
8030:12	User scale gain	Gain of the user scaling	INT32	RW	0x00010000 (65536 <sub>dec</sub> )
8030:13	Limit 1	Value for limit 1	INT16	RW	0x0000 (0 <sub>dec</sub> )
8030:14	Limit 2	Value for limit 2	INT16	RW	0x0000 (0 <sub>dec</sub> )
8030:15	Filter settings	Filter settings	UINT16	RW	0x0000 (0 <sub>dec</sub> )
		0 50 Hz			
		1 60 Hz			
		2 100 Hz			
		3 500 Hz			
		4 1 kHz,			
		5 2 kHz			
		6 3.75 kHz			
		7 7.5 kHz			
		8 15 kHz			
		9 30 kHz			
		10 5 Hz			
		11 10 Hz			
8030:16	Calibration interval	reserved	UINT16	RW	0x0000 (0 <sub>dec</sub> )
8030:17	User calibration offset	User calibration offset	INT16	RW	0x0000 (0 <sub>dec</sub> )
8030:18	User calibration gain	Gain of the user calibration	UINT16	RW	0x4000 (16384 <sub>dec</sub> )
8030:19	RTD element	Sensor type	UINT16	RW	0x0000 (0 <sub>dec</sub> )
		0 Pt100			
		1 Ni100			
		2 Pt1000			
		3 Pt500			
		4 Pt200			
		5 Ni1000			
		6 Ni1000 (Siemens)			
		7 Ni120			
		8 Resistance measurement with 1/16 ohm resolution			
		9 Resistance measurement with 1/64 ohm resolution			
8030:1A	Connection technology	Connection technology:	UINT16	RW	0x0000 (0 <sub>dec</sub> )
		0 2-wire			
		1 3-wire			
		2 4-wire			
		3 No sensor connected (only supported by hardware version 00): This setting skips the whole measurement, thus speeding up the data acquisition for the other channels. The green status LED of the respective channel remains lit. The error bit of a deactivated channel is canceled and no longer set.			
8030:1B	Wire calibration 1/32 Ohm	Only for 2-wire measurements: contains the resistance of the supply line for the temperature sensor (in 1/32 ohm).	INT16	RW	0x0000 (0 <sub>dec</sub> )

**6.4.2 Objects for regular operation**

EPP3204 has no such objects.

### 6.4.3 Standard objects (0x1000-0x1FFF)

The standard objects have the same meaning for all EtherCAT slaves.

#### Index 1000: Device type

Index (hex)	Name	Meaning	Data type	Flags	Default
1000:0	Device type	Device type of the EtherCAT slave: The Low-Word contains the CoE profile used (5001). The High-Word contains the module profile according to the modular device profile.	UINT32	RO	0x01401389 (20976521 <sub>dec</sub> )

#### Index 1008: Device name

Index (hex)	Name	Meaning	Data type	Flags	Default
1008:0	Device name	Device name of the EtherCAT slave	STRING	RO	EP3204-0002

#### Index 1009: Hardware version

Index (hex)	Name	Meaning	Data type	Flags	Default
1009:0	Hardware version	Hardware version of the EtherCAT slave	STRING	RO	05

#### Index 100A: Software version

Index (hex)	Name	Meaning	Data type	Flags	Default
100A:0	Software version	Firmware version of the EtherCAT slave	STRING	RO	07

#### Index 1018: Identity

Index (hex)	Name	Meaning	Data type	Flags	Default
1018:0	Identity	Information for identifying the slave	UINT8	RO	0x04 (4 <sub>dec</sub> )
1018:01	Vendor ID	Vendor ID of the EtherCAT slave	UINT32	RO	0x00000002 (2 <sub>dec</sub> )
1018:02	Product code	Product code of the EtherCAT slave	UINT32	RO	0x0C844052 (209993810 <sub>dec</sub> )
1018:03	Revision	Revision number of the EtherCAT slave; the low word (bit 0-15) indicates the special terminal number, the high word (bit 16-31) refers to the device description	UINT32	RO	0x00120002 (1179650 <sub>dec</sub> )
1018:04	Serial number	Serial number of the EtherCAT slave; the low byte (bit 0-7) of the low word contains the year of production, the high byte (bit 8-15) of the low word contains the week of production, the high word (bit 16-31) is 0	UINT32	RO	0x00000000 (0 <sub>dec</sub> )

#### Index 10F0: Backup parameter handling

Index (hex)	Name	Meaning	Data type	Flags	Default
10F0:0	Backup parameter handling	Information for standardized loading and saving of backup entries	UINT8	RO	0x01 (1 <sub>dec</sub> )
10F0:01	Checksum	Checksum across all backup entries of the EtherCAT slave	UINT32	RO	0x00000000 (0 <sub>dec</sub> )

#### Index 1A00: RTD TxPDO-Map RTDInputs Ch.1

Index (hex)	Name	Meaning	Data type	Flags	Default
1A00:0	RTD TxPDO-Map RTDInputs Ch.1	PDO Mapping TxPDO 1	UINT8	RO	0x09 (9 <sub>dec</sub> )
1A00:01	SubIndex 001	1. PDO Mapping entry	UINT32	RO	0x6000:01, 1
1A00:02	SubIndex 002	2. PDO Mapping entry	UINT32	RO	0x6000:02, 1
1A00:03	SubIndex 003	3. PDO Mapping entry	UINT32	RO	0x6000:03, 2
1A00:04	SubIndex 004	4. PDO Mapping entry	UINT32	RO	0x6000:05, 2
1A00:05	SubIndex 005	5. PDO Mapping entry	UINT32	RO	0x6000:07, 1
1A00:06	SubIndex 006	6. PDO Mapping entry (7 bits align)	UINT32	RO	0x0000:00, 7
1A00:07	SubIndex 007	7. PDO Mapping entry	UINT32	RO	0x6000:0, 1
1A00:08	SubIndex 008	8. PDO Mapping entry	UINT32	RO	0x6000:10, 1
1A00:09	SubIndex 009	9. PDO Mapping entry	UINT32	RO	0x6000:11, 16

**Index 1A01: RTD TxPDO-Map RTDInputs Ch.2**

Index (hex)	Name	Meaning	Data type	Flags	Default
1A01:0	RTD TxPDO-Map RTDInputs Ch.2	PDO Mapping TxPDO 2	UINT8	RO	0x09 (9 <sub>dez</sub> )
1A01:01	SubIndex 001	1. PDO Mapping entry	UINT32	RO	0x6010:01, 1
1A01:02	SubIndex 002	2. PDO Mapping entry	UINT32	RO	0x6010:02, 1
1A01:03	SubIndex 003	3. PDO Mapping entry	UINT32	RO	0x6010:03, 2
1A01:04	SubIndex 004	4. PDO Mapping entry	UINT32	RO	0x6010:05, 2
1A01:05	SubIndex 005	5. PDO Mapping entry	UINT32	RO	0x6010:07, 1
1A01:06	SubIndex 006	6. PDO Mapping entry (7 bits align)	UINT32	RO	0x0000:00, 7
1A01:07	SubIndex 007	7. PDO Mapping entry	UINT32	RO	0x6010:0F, 1
1A01:08	SubIndex 008	8. PDO Mapping entry	UINT32	RO	0x6010:10, 1
1A01:09	SubIndex 009	9. PDO Mapping entry	UINT32	RO	0x6010:11, 16

**Index 1A02: RTD TxPDO-Map RTDInputs Ch.3**

Index (hex)	Name	Meaning	Data type	Flags	Default
1A02:0	RTD TxPDO-Map RTDInputs Ch.3	PDO Mapping TxPDO 3	UINT8	RO	0x09 (9 <sub>dez</sub> )
1A02:01	SubIndex 001	1. PDO Mapping entry	UINT32	RO	0x6020:01, 1
1A02:02	SubIndex 002	2. PDO Mapping entry	UINT32	RO	0x6020:02, 1
1A02:03	SubIndex 003	3. PDO Mapping entry	UINT32	RO	0x6020:03, 2
1A02:04	SubIndex 004	4. PDO Mapping entry	UINT32	RO	0x6020:05, 2
1A02:05	SubIndex 005	5. PDO Mapping entry	UINT32	RO	0x6020:07, 1
1A02:06	SubIndex 006	6. PDO Mapping entry (7 bits align)	UINT32	RO	0x0000:00, 7
1A02:07	SubIndex 007	7. PDO Mapping entry	UINT32	RO	0x6020:0F, 1
1A02:08	SubIndex 008	8. PDO Mapping entry	UINT32	RO	0x6020:10, 1
1A02:09	SubIndex 009	9. PDO Mapping entry	UINT32	RO	0x6020:11, 16

**Index 1A03: RTD TxPDO-Map RTDInputs Ch.4**

Index (hex)	Name	Meaning	Data type	Flags	Default
1A03:0	RTD TxPDO-Map RTDInputs Ch.4	PDO Mapping TxPDO 4	UINT8	RO	0x09 (9 <sub>dez</sub> )
1A03:01	SubIndex 001	1. PDO Mapping entry	UINT32	RO	0x6030:01, 1
1A03:02	SubIndex 002	2. PDO Mapping entry	UINT32	RO	0x6030:02, 1
1A03:03	SubIndex 003	3. PDO Mapping entry	UINT32	RO	0x6030:03, 2
1A03:04	SubIndex 004	4. PDO Mapping entry	UINT32	RO	0x6030:05, 2
1A03:05	SubIndex 005	5. PDO Mapping entry	UINT32	RO	0x6030:07, 1
1A03:06	SubIndex 006	6. PDO Mapping entry (7 bits align)	UINT32	RO	0x0000:00, 7
1A03:07	SubIndex 007	7. PDO Mapping entry	UINT32	RO	0x6030:0F, 1
1A03:08	SubIndex 008	8. PDO Mapping entry	UINT32	RO	0x6030:10, 1
1A03:09	SubIndex 009	9. PDO Mapping entry	UINT32	RO	0x6030:11, 16

**Index 1C00: Sync manager type**

Index (hex)	Name	Meaning	Data type	Flags	Default
1C00:0	Sync manager type	Using the sync managers	UINT8	RO	0x04 (4 <sub>dec</sub> )
1C00:01	SubIndex 001	Sync-Manager Type Channel 1: Mailbox Write	UINT8	RO	0x01 (1 <sub>dec</sub> )
1C00:02	SubIndex 002	Sync-Manager Type Channel 2: Mailbox Read	UINT8	RO	0x02 (2 <sub>dec</sub> )
1C00:03	SubIndex 003	Sync-Manager Type Channel 3: Process Data Write (Outputs)	UINT8	RO	0x03 (3 <sub>dec</sub> )
1C00:04	SubIndex 004	Sync-Manager Type Channel 4: Process Data Read (Inputs)	UINT8	RO	0x04 (4 <sub>dec</sub> )

**Index 1C12: RxPDO assign**

Index (hex)	Name	Meaning	Data type	Flags	Default
1C12:0	RxPDO assign	PDO Assign Outputs	UINT8	RW	0x00 (0 <sub>dec</sub> )

**Index 1C13: TxPDO assign**

Index (hex)	Name	Meaning	Data type	Flags	Default
1C13:0	TxPDO assign	PDO Assign Inputs	UINT8	RW	0x04 (4 <sub>dec</sub> )
1C13:01	Subindex 001	1. allocated TxPDO (contains the index of the associated TxPDO mapping object)	UINT16	RW	0x1A00 (6656 <sub>dec</sub> )
1C13:02	Subindex 002	2. allocated TxPDO (contains the index of the associated TxPDO mapping object)	UINT16	RW	0x1A01 (6657 <sub>dec</sub> )
1C13:03	Subindex 003	3. allocated TxPDO (contains the index of the associated TxPDO mapping object)	UINT16	RW	0x1A02 (6658 <sub>dec</sub> )
1C13:04	Subindex 004	4. allocated TxPDO (contains the index of the associated TxPDO mapping object)	UINT16	RW	0x1A03 (6659 <sub>dec</sub> )

**Index 1C33: SM input parameter**

Index (hex)	Name	Meaning	Data type	Flags	Default
1C33:0	SM input parameter	Maximum subindex	UINT8	RO	0x20 (32 <sub>dec</sub> )
1C33:01	Sync mode		UINT16	RW	0x0000 (0 <sub>dec</sub> )
1C33:02	Cycle time		UINT32	RW	0x000F4240 (1000000 <sub>dec</sub> )
1C33:03	Shift time		UINT32	RO	0x00000000 (0 <sub>dec</sub> )
1C33:04	Sync modes supported		UINT16	RO	0xC007 (49159 <sub>dec</sub> )
1C33:05	Minimum cycle time		UINT32	RO	0x00002710 (10000 <sub>dec</sub> )
1C33:06	Calc and copy time		UINT32	RO	0x00000000 (0 <sub>dec</sub> )
1C33:07	Minimum delay time		UINT32	RO	0x00000000 (0 <sub>dec</sub> )
1C33:08	Command		UINT16	RW	0x0000 (0 <sub>dec</sub> )
1C33:09	Maximum Delay time		UINT32	RO	0x00000000 (0 <sub>dec</sub> )
1C33:0B	SM event missed counter		UINT16	RO	0x0000 (0 <sub>dec</sub> )
1C33:0C	Cycle exceeded counter		UINT16	RO	0x0000 (0 <sub>dec</sub> )
1C33:0D	Shift too short counter		UINT16	RO	0x0000 (0 <sub>dec</sub> )
1C33:20	Sync error		BOOLEAN	RO	0x00 (0 <sub>dec</sub> )



## 6.4.4 Profile-specific objects (0x6000-0xFFFF)

The profile-specific objects have the same meaning for all EtherCAT slaves that support the profile 5001.

### Index 6000: RTD Inputs Ch.1

Index (hex)	Name	Meaning	Data type	Flags	Default
6000:0	RTD Inputs Ch.1	Maximum subindex	UINT8	RO	0x11 (17 <sub>dec</sub> )
6000:01	Underrange	Is set if the value falls below the operating range of the sensor or the process record contains the lowest possible value.	BOOLEAN	RO	0x00 (0 <sub>dec</sub> )
6000:02	Overrange	Is set if the value exceeds the operating range of the sensor or the process record contains the highest possible value.	BOOLEAN	RO	0x00 (0 <sub>dec</sub> )
6000:03	Limit 1	Only when limit check is active	BIT2	RO	0x00 (0 <sub>dec</sub> )
		1 Value below set limit			
		2 Set limit exceeded			
		3 Set limit reached			
6000:05	Limit 2	Only when limit check is active	BIT2	RO	0x00 (0 <sub>dec</sub> )
		1 Value below set limit			
		2 Set limit exceeded			
		3 Set limit reached			
6000:07	Error	The error bit is set if the process data is invalid (wire breakage, overrange, underrange).	BOOLEAN	RO	0x00 (0 <sub>dec</sub> )
6000:0E	Sync error	Only in DC: bit is set if the slave is not able to operate synchronous with master, because it cannot keep up with the cycle time.	BOOLEAN	RO	0x00 (0 <sub>dec</sub> )
6000:0F	TxPDO State	Validity of the data of the associated TxPDO	BOOLEAN	RO	0x00 (0 <sub>dec</sub> )
		0 valid			
		1 invalid			
6000:10	TxPDO Toggle	TxPDO toggle is toggled by the slave when the data of the associated TxPDO is updated.	BOOLEAN	RO	0x00 (0 <sub>dec</sub> )
6000:11	Value	Analog input date	INT16	RO	0x0000 (0 <sub>dec</sub> )

### Index 6010: RTD Inputs Ch.2

Index (hex)	Name	Meaning	Data type	Flags	Default
6010:0	RTD Inputs Ch.2	Maximum subindex	UINT8	RO	0x11 (17 <sub>dec</sub> )
6010:01	Underrange	Is set if the value falls below the operating range of the sensor or the process record contains the lowest possible value.	BOOLEAN	RO	0x00 (0 <sub>dec</sub> )
6010:02	Overrange	Is set if the value exceeds the operating range of the sensor or the process record contains the highest possible value.	BOOLEAN	RO	0x00 (0 <sub>dec</sub> )
6010:03	Limit 1	Only when limit check is active	BIT2	RO	0x00 (0 <sub>dec</sub> )
		1 Value below set limit			
		2 Set limit exceeded			
		3 Set limit reached			
6010:05	Limit 2	Only when limit check is active	BIT2	RO	0x00 (0 <sub>dec</sub> )
		1 Value below set limit			
		2 Set limit exceeded			
		3 Set limit reached			
6010:07	Error	The error bit is set if the process data is invalid (wire breakage, overrange, underrange).	BOOLEAN	RO	0x00 (0 <sub>dec</sub> )
6010:0E	Sync error	Only in DC: bit is set if the slave is not able to operate synchronous with master, because it cannot keep up with the cycle time.	BOOLEAN	RO	0x00 (0 <sub>dec</sub> )
6010:0F	TxPDO State	Validity of the data of the associated TxPDO	BOOLEAN	RO	0x00 (0 <sub>dec</sub> )
		0 valid			
		1 invalid			
6010:10	TxPDO Toggle	TxPDO toggle is toggled by the slave when the data of the associated TxPDO is updated.	BOOLEAN	RO	0x00 (0 <sub>dec</sub> )
6010:11	Value	Analog input date	INT16	RO	0x0000 (0 <sub>dec</sub> )

## Index 6020: RTD Inputs Ch.3

Index (hex)	Name	Meaning	Data type	Flags	Default
6020:0	RTD Inputs Ch.3	Maximum subindex	UINT8	RO	0x11 (17 <sub>dec</sub> )
6020:01	Underrange	Is set if the value falls below the operating range of the sensor or the process record contains the lowest possible value.	BOOLEAN	RO	0x00 (0 <sub>dec</sub> )
6020:02	Overrange	Is set if the value exceeds the operating range of the sensor or the process record contains the highest possible value.	BOOLEAN	RO	0x00 (0 <sub>dec</sub> )
6020:03	Limit 1	Only when limit check is active	BIT2	RO	0x00 (0 <sub>dec</sub> )
		1 Value below set limit			
		2 Set limit exceeded			
		3 Set limit reached			
6020:05	Limit 2	Only when limit check is active	BIT2	RO	0x00 (0 <sub>dec</sub> )
		1 Value below set limit			
		2 Set limit exceeded			
		3 Set limit reached			
6020:07	Error	The error bit is set if the process data is invalid (cable break, overrange, underrange)	BOOLEAN	RO	0x00 (0 <sub>dec</sub> )
6020:0E	Sync error	Only in DC: bit is set if the slave is not able to operate synchronous with master, because it cannot keep up with the cycle time.	BOOLEAN	RO	0x00 (0 <sub>dec</sub> )
6020:0F	TxPDO State	Validity of the data of the associated TxPDO	BOOLEAN	RO	0x00 (0 <sub>dec</sub> )
		0 valid			
		1 invalid			
6020:10	TxPDO Toggle	TxPDO toggle is toggled by the slave when the data of the associated TxPDO is updated.	BOOLEAN	RO	0x00 (0 <sub>dec</sub> )
6020:11	Value	Analog input date	INT16	RO	0x0000 (0 <sub>dec</sub> )

## Index 6030: RTD Inputs Ch.4

Index (hex)	Name	Meaning	Data type	Flags	Default
6030:0	RTD Inputs Ch.4	Maximum subindex	UINT8	RO	0x11 (17 <sub>dec</sub> )
6030:01	Underrange	Is set if the value falls below the operating range of the sensor or the process record contains the lowest possible value.	BOOLEAN	RO	0x00 (0 <sub>dec</sub> )
6030:02	Overrange	Is set if the value exceeds the operating range of the sensor or the process record contains the highest possible value.	BOOLEAN	RO	0x00 (0 <sub>dec</sub> )
6030:03	Limit 1	Only when limit check is active	BIT2	RO	0x00 (0 <sub>dec</sub> )
		1 Value below set limit			
		2 Set limit exceeded			
		3 Set limit reached			
6030:05	Limit 2	Only when limit check is active	BIT2	RO	0x00 (0 <sub>dec</sub> )
		1 Value below set limit			
		2 Set limit exceeded			
		3 Set limit reached			
6030:07	Error	The error bit is set if the process data is invalid (wire breakage, overrange, underrange).	BOOLEAN	RO	0x00 (0 <sub>dec</sub> )
6030:0E	Sync error	Only in DC: bit is set if the slave is not able to operate synchronous with master, because it cannot keep up with the cycle time.	BOOLEAN	RO	0x00 (0 <sub>dec</sub> )
6030:0F	TxPDO State	Validity of the data of the associated TxPDO	BOOLEAN	RO	0x00 (0 <sub>dec</sub> )
		0 valid			
		1 invalid			
6030:10	TxPDO Toggle	TxPDO toggle is toggled by the slave when the data of the associated TxPDO is updated.	BOOLEAN	RO	0x00 (0 <sub>dec</sub> )
6030:11	Value	Analog input date	INT16	RO	0x0000 (0 <sub>dec</sub> )

**Index 800E: RTD Internal data Ch.1**

Index (hex)	Name	Meaning	Data type	Flags	Default
800E:0	RTD Internal data Ch.1	Maximum subindex	UINT8	RO	0x04 (4 <sub>dec</sub> )
800E:01	ADC raw value 1	Raw value of the analog/digital converter	INT32	RO	0x00000000 (0 <sub>dec</sub> )
800E:02	Resistor 1	Resistance value of the first measurement	UINT16	RO	0x0000 (0 <sub>dec</sub> )
800E:03	ADC raw value 2	Raw value of the analog/digital converter	INT32	RO	0x00000000 (0 <sub>dec</sub> )
800E:04	Resistor 2	Resistance value of the second measurement	UINT16	RO	0x0000 (0 <sub>dec</sub> )

**Index 800F: RTD Vendor data Ch.1**

Index (hex)	Name	Meaning	Data type	Flags	Default
800F:0	RTD Vendor data Ch.1	Maximum subindex	UINT8	RO	0x07 (7 <sub>dec</sub> )
800F:01	Calibration offset 3-wire	Calibration for 3-wire measurement: Offset	INT16	RW	0x0000 (0 <sub>dec</sub> )
800F:02	Calibration gain 3-wire	Calibration for 3-wire measurement: Gain	UINT16	RW	0x4000 (16384 <sub>dec</sub> )
800F:03	Calibration offset 2-wire	Calibration for 2-wire measurement: Offset	INT16	RW	0x0000 (0 <sub>dec</sub> )
800F:04	Calibration gain 2-wire	Calibration for 2-wire measurement: Gain	UINT16	RW	0x4000 (16384 <sub>dec</sub> )
800F:05	Calibration offset 4-wire	Calibration for 4-wire measurement: Offset	INT16	RW	0x0000 (0 <sub>dec</sub> )
800F:06	Calibration gain 4-wire	Calibration for 4-wire measurement: Gain	UINT16	RW	0x4000 (16384 <sub>dec</sub> )
800F:07	PGA Gain Correction	Gain correction for Pt1000 measurement	INT16	RW	0x0000 (0 <sub>dec</sub> )

**Index 801E: RTD Internal data Ch.2**

Index (hex)	Name	Meaning	Data type	Flags	Default
801E:0	RTD Internal data Ch.2	Maximum subindex	UINT8	RO	0x04 (4 <sub>dec</sub> )
801E:01	ADC raw value 1	Raw value of the analog/digital converter	INT32	RO	0x00000000 (0 <sub>dec</sub> )
801E:02	Resistor 1	Resistance value of the first measurement	UINT16	RO	0x0000 (0 <sub>dec</sub> )
801E:03	ADC raw value 2	Raw value of the analog/digital converter	INT32	RO	0x00000000 (0 <sub>dec</sub> )
801E:04	Resistor 2	Resistance value of the second measurement	UINT16	RO	0x0000 (0 <sub>dec</sub> )

**Index 801F: RTD Vendor data Ch.2**

Index (hex)	Name	Meaning	Data type	Flags	Default
801F:0	RTD Vendor data Ch.2	Maximum subindex	UINT8	RO	0x07 (7 <sub>dec</sub> )
801F:01	Calibration offset 3-wire	Calibration for 3-wire measurement: Offset	INT16	RW	0x0000 (0 <sub>dec</sub> )
801F:02	Calibration gain 3-wire	Calibration for 3-wire measurement: Gain	UINT16	RW	0x4000 (16384 <sub>dec</sub> )
801F:03	Calibration offset 2-wire	Calibration for 2-wire measurement: Offset	INT16	RW	0x0000 (0 <sub>dec</sub> )
801F:04	Calibration gain 2-wire	Calibration for 2-wire measurement: Gain	UINT16	RW	0x4000 (16384 <sub>dec</sub> )
801F:05	Calibration offset 4-wire	Calibration for 4-wire measurement: Offset	INT16	RW	0x0000 (0 <sub>dec</sub> )
801F:06	Calibration gain 4-wire	Calibration for 4-wire measurement: Gain	UINT16	RW	0x4000 (16384 <sub>dec</sub> )
801F:07	PGA Gain Correction	Gain correction for Pt1000 measurement	INT16	RW	0x0000 (0 <sub>dec</sub> )

**Index 802E: RTD Internal data Ch.3**

Index (hex)	Name	Meaning	Data type	Flags	Default
802E:0	RTD Internal data Ch.3	Maximum subindex	UINT8	RO	0x04 (4 <sub>dec</sub> )
802E:01	ADC raw value 1	Raw value of the analog/digital converter	INT32	RO	0x00000000 (0 <sub>dec</sub> )
802E:02	Resistor 1	Resistance value of the first measurement	UINT16	RO	0x0000 (0 <sub>dec</sub> )
802E:03	ADC raw value 2	Raw value of the analog/digital converter	INT32	RO	0x00000000 (0 <sub>dec</sub> )
802E:04	Resistor 2	Resistance value of the second measurement	UINT16	RO	0x0000 (0 <sub>dec</sub> )

**Index 802F: RTD Vendor data Ch.3**

Index (hex)	Name	Meaning	Data type	Flags	Default
802F:0	RTD Vendor data Ch.3	Maximum subindex	UINT8	RO	0x07 (7 <sub>dec</sub> )
802F:01	Calibration offset 3-wire	Calibration for 3-wire measurement: Offset	INT16	RW	0x0000 (0 <sub>dec</sub> )
802F:02	Calibration gain 3-wire	Calibration for 3-wire measurement: Gain	UINT16	RW	0x4000 (16384 <sub>dec</sub> )
802F:03	Calibration offset 2-wire	Calibration for 2-wire measurement: Offset	INT16	RW	0x0000 (0 <sub>dec</sub> )
802F:04	Calibration gain 2-wire	Calibration for 2-wire measurement: Gain	UINT16	RW	0x4000 (16384 <sub>dec</sub> )
802F:05	Calibration offset 4-wire	Calibration for 4-wire measurement: Offset	INT16	RW	0x0000 (0 <sub>dec</sub> )
802F:06	Calibration gain 4-wire	Calibration for 4-wire measurement: Gain	UINT16	RW	0x4000 (16384 <sub>dec</sub> )
802F:07	PGA Gain Correction	Gain correction for Pt1000 measurement	INT16	RW	0x0000 (0 <sub>dec</sub> )

**Index 803E: RTD Internal data Ch.4**

Index (hex)	Name	Meaning	Data type	Flags	Default
803E:0	RTD Internal data Ch.4	Maximum subindex	UINT8	RO	0x04 (4 <sub>dec</sub> )
803E:01	ADC raw value 1	Raw value of the analog/digital converter	INT32	RO	0x00000000 (0 <sub>dec</sub> )
803E:02	Resistor 1	Resistance value of the first measurement	UINT16	RO	0x0000 (0 <sub>dec</sub> )
803E:03	ADC raw value 2	Raw value of the analog/digital converter	INT32	RO	0x00000000 (0 <sub>dec</sub> )
803E:04	Resistor 2	Resistance value of the second measurement	UINT16	RO	0x0000 (0 <sub>dec</sub> )

**Index 803F: RTD Vendor data Ch.4**

Index (hex)	Name	Meaning	Data type	Flags	Default
803F:0	RTD Vendor data Ch.4		UINT8	RO	0x07 (7 <sub>dec</sub> )
803F:01	Calibration offset 3-wire	Calibration for 3-wire measurement: Offset	INT16	RW	0x0000 (0 <sub>dec</sub> )
803F:02	Calibration gain 3-wire	Calibration for 3-wire measurement: Gain	UINT16	RW	0x4000 (16384 <sub>dec</sub> )
803F:03	Calibration offset 2-wire	Calibration for 2-wire measurement: Offset	INT16	RW	0x0000 (0 <sub>dec</sub> )
803F:04	Calibration gain 2-wire	Calibration for 2-wire measurement: Gain	UINT16	RW	0x4000 (16384 <sub>dec</sub> )
803F:05	Calibration offset 4-wire	Calibration for 4-wire measurement: Offset	INT16	RW	0x0000 (0 <sub>dec</sub> )
803F:06	Calibration gain 4-wire	Calibration for 4-wire measurement: Gain	UINT16	RW	0x4000 (16384 <sub>dec</sub> )
803F:07	PGA Gain Correction	Gain correction for Pt1000 measurement	INT16	RW	0x0000 (0 <sub>dec</sub> )

**Index F000: Modular device profile**

Index (hex)	Name	Meaning	Data type	Flags	Default
F000:0	Modular device profile	Maximum subindex	UINT8	RO	0x02 (2 <sub>dec</sub> )
F000:01	Module index distance	Index spacing for the objects of the individual channels	UINT16	RO	0x0010 (16 <sub>dec</sub> )
F000:02	Maximum number of modules	Number of channels	UINT16	RO	0x0004 (4 <sub>dec</sub> )

**Index F008: Code word**

Index (hex)	Name	Meaning	Data type	Flags	Default
F008:0	Code word	reserved	UINT32	RW	0x00000000 (0 <sub>dec</sub> )

**Index F010: Module list**

Index (hex)	Name	Meaning	Data type	Flags	Default
F010:0	Module list	Maximum subindex	UINT8	RW	0x04 (4 <sub>dec</sub> )
F010:01	SubIndex 001		UINT32	RW	0x00000140 (320 <sub>dec</sub> )
F010:02	SubIndex 002		UINT32	RW	0x00000140 (320 <sub>dec</sub> )
F010:03	SubIndex 003		UINT32	RW	0x00000140 (320 <sub>dec</sub> )
F010:04	SubIndex 004		UINT32	RW	0x00000140 (320 <sub>dec</sub> )

**Index F080: Channel Enable**

Index (hex)	Name	Meaning	Data type	Flags	Default	
F080:0	Channel Enable	Maximum subindex	UINT8	RO	0x04 (4 <sub>dec</sub> )	
F080:01	SubIndex 001	0 Channel 1 disabled	(from hardware version 01 deactivated channels are not measured, and the green LED R for these channels goes out)	BOOLEAN	RW	0x01 (1 <sub>dec</sub> )
		1 Channel 1 enabled				
F080:02	SubIndex 002	0 Channel 2 disabled		BOOLEAN	RW	0x01 (1 <sub>dec</sub> )
		1 Channel 2 enabled				
F080:03	SubIndex 003	0 Channel 3 disabled		BOOLEAN	RW	0x01 (1 <sub>dec</sub> )
		1 Channel 3 enabled				
F080:04	SubIndex 004	0 Channel 4 disabled		BOOLEAN	RW	0x01 (1 <sub>dec</sub> )
		1 Channel 5 enabled				

## 6.5 EP3314 - Settings

### 6.5.1 Cold junction compensation

You can set the cold junction compensation type for each channel individually in the parameters  $80n0:0C_{\text{hex}}$  "Coldjunction Compensation".

- Channel 1: Parameter  $8000:0C_{\text{hex}}$
- Channel 2: Parameter  $8010:0C_{\text{hex}}$
- Channel 3: Parameter  $8020:0C_{\text{hex}}$
- Channel 4: Parameter  $8030:0C_{\text{hex}}$

The possible values for these parameters are described below.

#### Value 0 "intern"

In the factory setting, all parameters  $80n0:0C_{\text{hex}}$  are set to "intern". With this setting, the cold junction temperature is measured individually at each channel.

A Pt1000 measuring resistor must also be connected to each channel to which a thermocouple is connected. See [Connection example 1 \[▶ 41\]](#).

#### Value 1 "none"

No cold junction compensation is performed.

#### Value 2 "external process data (1/100°C)"

This setting is intended for a situation where the cold junction temperature is measured with a separate measuring device, for example.

Enable the process data  $0x1600$  to  $0x1603$  in the Process Data tab. You can transfer the externally measured cold junction temperatures to the box via the process data objects "TC Outputs Channel  $n$ ".

#### Value 3 "by coldjunction temp. of channel 1"

With this setting, the cold junction temperature of channel 1 is used for cold junction compensation of the other channels. This saves the costs of a separate Pt1000 resistor for each channel. See [Connection example 2 \[▶ 42\]](#).

However, large measuring errors can occur with this setting. The setting is only recommended if the temperature difference between the cold junction of a channel and the cold junction of channel 1 is constant.

Example: Enabling the cold junction of channel 1 for channel 2

1. Make sure that the temperature difference between the cold junctions of the channels is as constant as possible.
2. Set the parameter  $8010:0C_{\text{hex}}$  "Coldjunction Compensation" to the value "by coldjunction temp. of channel 1".
3. Determine the constant temperature difference between the cold junctions of channel 1 and channel 2:  

$$T_{\text{delta}} = T_{V1} - T_{V2}$$
 If the cold junction of channel 1 is warmer than that of channel 2, the value  $T_{\text{delta}}$  is positive.
4. Enter the temperature offset in parameter  $8010:1C_{\text{hex}}$  "Coldjunction temperature offset from channel 1". The unit is 1/100 °C.  
 Example: for a temperature difference of 0.5 °C enter the value 50 here.

The procedure is the same for channels 3 and 4. The corresponding parameters are:

- Channel 3
  - $8020:0C_{\text{hex}}$  „Coldjunction Compensation“
  - $8020:1C_{\text{hex}}$  „Coldjunction temperature offset from channel 1“
- Channel 4

- 8030:0C<sub>hex</sub> „Coldjunction Compensation“
- 8030:1C<sub>hex</sub> „Coldjunction temperature offset from channel 1“

## 6.5.2 Presentation, index 0x80n0:02

Index 0x80n0:02 “Presentation” offers the possibility to change the method of representation of the measured value.

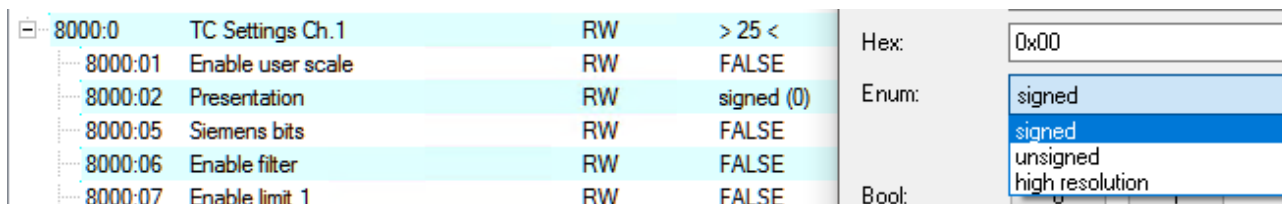

Fig. 16: Index 0x8000:02, selection of the representation

Three value representations are possible in the 16bit PDO:

- **Signed Integer (default setting):**

The measured value with resolution 1 bit = 1/10°C is displayed signed in two's complement. Maximum representation range for 16 bit = -32768 ... +32767, corresponding theoretically to -3276.8°C ... +3276.7°C (in reality the measured value is limited by the set transformation).

Example:

- 1000 0000 0000 0000<sub>bin</sub> = 0x8000<sub>hex</sub> = - 32768<sub>dec</sub>
- 1111 1111 1111 1110<sub>bin</sub> = 0xFFFFE<sub>hex</sub> = - 2<sub>dec</sub>
- 1111 1111 1111 1111<sub>bin</sub> = 0xFFFF<sub>hex</sub> = - 1<sub>dec</sub>
- 0000 0000 0000 0001<sub>bin</sub> = 0x0001<sub>hex</sub> = +1<sub>dec</sub>
- 0000 0000 0000 0010<sub>bin</sub> = 0x0002<sub>hex</sub> = +2<sub>dec</sub>
- 0111 1111 1111 1111<sub>bin</sub> = 0x7FFF<sub>hex</sub> = +32767<sub>dec</sub>

```

K -270...1372°C
J -210...1200°C
L -50...900°C
E -270...1000°C
T -270...400°C
N -270...1300°C
U -50...600°C
B 200...1820°C
R -50...1768°C
S -50...1768°C
C 0...2320°C

```

Fig. 17: Selection options transformation

- **High resolution:**

The measured value with resolution 1 bit = 1/100°C is displayed signed in two's complement, see there. Maximum representation range for 16-bit = -32768 ... +32767, corresponding theoretically to -327.68°C ... +327.67°C (in reality the measured value is limited by the set transformation).

The achievable accuracy is not increased by the finer representation! However, the additional decimal place can be useful for control tasks, where the internal ADC resolution limits the resolution: for example, real measured value changes of 60 mK can be read for type K:



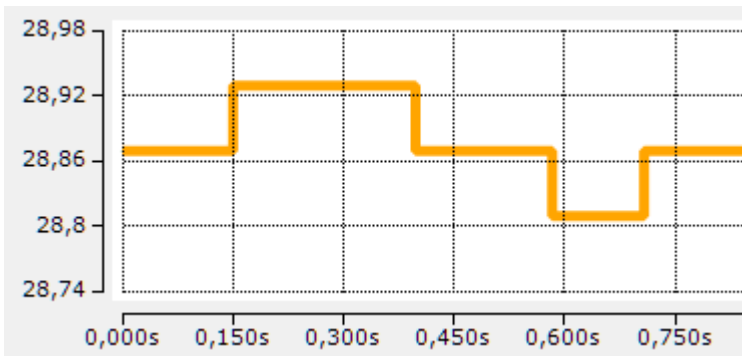

Fig. 18: Representation of measured value change thermocouple type K

Measured value	Output (hexadecimal)	Output (signed integer, decimal)	Corresponds in 1/10°C	Corresponds in 1/100°C
-200.0°C	0xF830	-2000	-200°C	-20°C
-100.0°C	0xFC18	-1000	-100°C	-10°C
-0.1°C	0xFFFF	-1	-0.1°C	-0.01°C
0.0°C	0x0000	0	0°C	0°C
0.1°C	0x0001	1	0.1°C	0.01°C
100.0°C	0x03E8	1000	100°C	10°C
200.0°C	0x07D0	2000	200°C	20°C
500.0°C	0x1388	5000	500°C	50°C
850.0°C	0x2134	8500	850°C	85°C
1000.0°C	0x2170	10000	1000°C	10°C

Table: Output of process data and measured value

• **Absolute value with MSB as sign:**

The measured value with resolution 1 bit = 1/10°C is output signed in the signed amount representation.

Maximum representation range with 16 bit = -32768 ... +32767, corresponding theoretically to -3276.8°C ... +3276.7°C (in reality the measured value is limited by the set transformation)

Example:

- 1111 1111 1111 1111<sub>bin</sub> = 0xFFFF<sub>hex</sub> = - 32767<sub>dec</sub>
- 1000 0000 0000 0010<sub>bin</sub> = 0x8002<sub>hex</sub> = - 2<sub>dec</sub>
- 1000 0000 0000 0001<sub>bin</sub> = 0x8001<sub>hex</sub> = - 1<sub>dec</sub>
- 0000 0000 0000 0001<sub>bin</sub> = 0x0001<sub>hex</sub> = +1<sub>dec</sub>
- 0000 0000 0000 0010<sub>bin</sub> = 0x0002<sub>hex</sub> = +2<sub>dec</sub>
- 0111 1111 1111 1111<sub>bin</sub> = 0x7FFF<sub>hex</sub> = +32767<sub>dec</sub>

### 6.5.3 Siemens bits, index 0x80n0:05

If the bit in index 0x80n0:05 is set, status displays are shown for the lowest 3 bits. In the error case "overrange" or "underrange", bit 0 is set.

### 6.5.4 Underrange, Overage

**Under- and overshoot of the measuring range (underrange index 0x60n0:01, overrange index 0x60n0:02)**

- $U_k > U_{k_{\max}}$ : Index 0x60n0:02 and index 0x60n0:07 (overrange and error bit) are set. The linearization of the characteristic curve is continued with the coefficients of the overrange limit up to the limit stop of the A/D converter or to the maximum value of 0x7FFF.
- $U_k < U_{k_{\min}}$ : Index 0x60n0:01 and index 0x60n0:07 (underrange and error bit) are set. The linearization of the characteristic curve is continued with the coefficients of the underrange limit up to the limit stop of the A/D converter or to the minimum value of 0x8000.

For overrange or underrange the red error LED is switched on.

### 6.5.5 Filter

Each analog input has a digital filter. The filter is a notch filter.

The filter is always active; it cannot be disabled. None of the "Enable Filter" parameters have any effect: 0x8000:06, 0x8010:06, 0x8020:06, 0x8030:06.

#### Configuring the filter

You can set the filter frequency in the parameter 0x8000:15 "Filter Settings". This parameter affects all channels. The "Filter Settings" parameters of the other channels have no effect: 0x8010:15, 0x8020:15, 0x8030:15.

#### Influence on the conversion time

The higher the filter frequency, the shorter the conversion time.

### 6.5.6 Limit 1 and Limit 2

**Limit 1 and limit 2, index 0x80n0:13, index 0x80n0:14**

A temperature range can be set that is limited by the values in the indices 0x80n0:13 and 0x80n0:14. If the limit values are overshoot, the bits in indices 0x80n0:07 and 0x80n0:08 are set.

The temperature value is entered with a resolution of 0.1 °C.

#### Example:

Limit 1= 30 °C  
Value index 0x80n0:13 = 300

## 6.5.7 Calibration

### Vendor calibration, index 0x80n0:0B

The vendor calibration is enabled via index 0x80n0:0B. Parameterization takes place via the indices

- 0x80nF:01  
Thermocouple offset (vendor calibration)
- 0x80nF:02  
Thermocouple gain (vendor calibration)
- 0x80nF:03  
Reference point offset [Pt1000] (vendor calibration)
- 0x80nF:04  
Reference point gain [Pt1000] (vendor calibration)

#### ● Vendor and user calibration



User calibration (index 0x80n0:0A) should only be performed instead of the vendor calibration (index 0x80n0:0B), but this is generally only necessary in exceptional cases.

### User calibration , index 0x80n0:0A

User calibration is enabled via index 0x80n0:0A. Parameterization takes place via the indices

- 0x80n0:17  
Thermocouple offset (index 0x80nF:01, user calibration)
- 0x80n0:18  
Thermocouple gain (index 0x80nF:02, user calibration)

### User scaling, index 0x80n0:01

The user scaling is enabled via index 0x80n0:01. Parameterization takes place via the indices

- 0x80n0:11  
User scaling offset

The offset describes a vertical shift of the characteristic curve by a linear amount.

At a resolution of  $0.1^\circ$ , 1 digit<sub>(dec)</sub> corresponds to an increase in measured value by  $0.1^\circ$

At a resolution of  $0.01^\circ$ , 1 digit<sub>(dec)</sub> corresponds to an increase in measured value by  $0.01$

- 0x80n0:12  
User scaling gain

The default value of 65536<sub>(dec)</sub> corresponds to gain = 1.

The new gain value for 2-point user calibration after offset calibration is determined as follows:

$$\text{Gain}_{\text{new}} = \text{reference temperature} / \text{measured value} \times 65536_{(\text{dec})}$$

### Calculation of process data

*The concept "calibration", which has historical roots at Beckhoff, is used here even if it has nothing to do with the deviation statements of a calibration certificate. Actually, this is a description of the vendor or customer calibration data/adjustment data used by the device during operation in order to maintain the assured measuring accuracy.*

The box constantly records measured values and saves the raw values from its A/D converter in the ADC raw value objects 0x80nE:01, 0x80nE:02. After each recording of the analog signal, the correction calculation takes place with the vendor and user calibration data as well as the user scaling, if these are activated (see following picture).

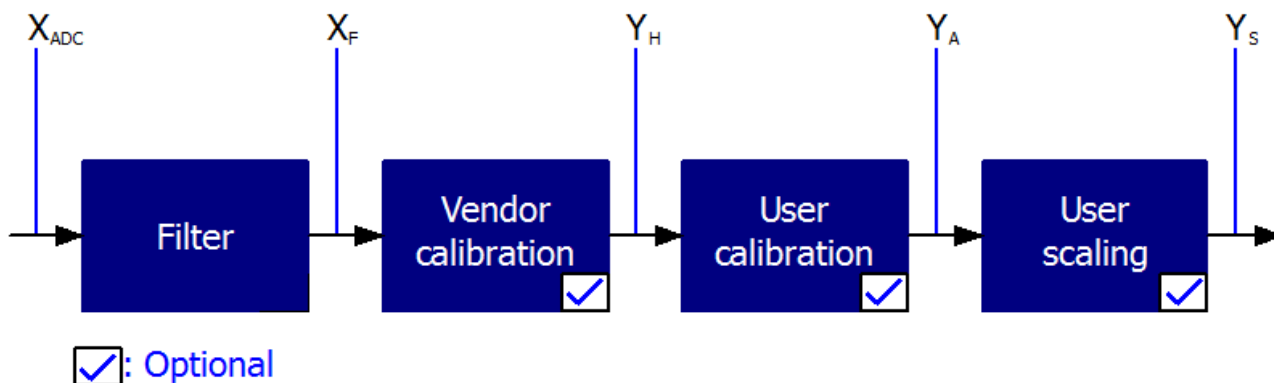

Fig. 19: Calculation of process data

Calculation	Designation
$X_{ADC}$	Output of the A/D converter
$X_F$	Output value after the filter
$Y_H = (X_{ADC} - B_H) \times A_H \times 2^{-14}$	Measured value after vendor calibration,
$Y_A = (Y_H - B_A) \times A_A \times 2^{-14}$	Measured value after vendor and user calibration
$Y_S = Y_A \times A_S \times 2^{-16} + B_S$	Measured value following user scaling

Table 1: Legend

Name	Designation	Index
$X_{ADC}$	Output value of the A/D converter	0x80nE:01
$X_F$	Output value after the filter	-
$B_H$	Vendor calibration offset (not changeable)	0x80nF:01
$A_H$	Vendor calibration gain (not changeable)	0x80nF:02
$B_A$	User calibration offset (can be activated via index 0x80n0:0A)	0x80n0:17
$A_A$	User calibration gain (can be activated via index 0x80n0:0A)	0x80n0:18
$B_S$	User scaling offset (can be activated via index 0x80n0:01)	0x80n0:11
$A_S$	User scaling gain (can be activated via index 0x80n0:01)	0x80n0:12
$Y_S$	Process data for controller	-

**i Measurement result**

The accuracy of the result may be reduced if the measured value is smaller than 32767 / 4 due to one or more multiplications.

## 6.6 EP3314 - object overview

### **i** EtherCAT XML Device Description

The display matches that of the CoE objects from the EtherCAT XML Device Description. We recommend downloading the latest XML file from the download area of the Beckhoff website and installing it according to installation instructions.

Index (hex)	Name	Flags	Default value	
<a href="#">1000 [▶ 98]</a>	Device type	RO	0x014A1389 (21631881 <sub>dec</sub> )	
<a href="#">1008 [▶ 98]</a>	Device name	RO	EP3314-0002	
<a href="#">1009 [▶ 98]</a>	Hardware version	RO	00	
<a href="#">100A [▶ 98]</a>	Software version	RO	01	
<a href="#">1011:0 [▶ 92]</a>	<b>Subindex</b>	Restore default parameters	RO	0x01 (1 <sub>dec</sub> )
	1011:01	SubIndex 001	RW	0x00000000 (0 <sub>dec</sub> )
<a href="#">1018:0 [▶ 98]</a>	<b>Subindex</b>	Identity	RO	0x04 (4 <sub>dec</sub> )
	1018:01	Vendor ID	RO	0x00000002 (2 <sub>dec</sub> )
	1018:02	Product code	RO	0x0CF24052 (217202770 <sub>dec</sub> )
	1018:03	Revision	RO	0x00100002 (1048578 <sub>dec</sub> )
	1018:04	Serial number	RO	0x00000000 (0 <sub>dec</sub> )
<a href="#">10F0:0 [▶ 98]</a>	<b>Subindex</b>	Backup parameter handling	RO	0x01 (1 <sub>dec</sub> )
	10F0:01	Checksum	RO	0x00000000 (0 <sub>dec</sub> )
<a href="#">1600:0 [▶ 98]</a>	<b>Subindex</b>	TC RxPDO-Map Outputs Ch.1	RO	0x01 (1 <sub>dec</sub> )
	1600:01	SubIndex 001	RO	0x7000:11, 16
<a href="#">1601:0 [▶ 99]</a>	<b>Subindex</b>	TC RxPDO-Map Outputs Ch.2	RO	0x01 (1 <sub>dec</sub> )
	1601:01	SubIndex 001	RO	0x7010:11, 16
<a href="#">1602:0 [▶ 99]</a>	<b>Subindex</b>	TC RxPDO-Map Outputs Ch.3	RO	0x01 (1 <sub>dec</sub> )
	1602:01	SubIndex 001	RO	0x7020:11, 16
<a href="#">1603:0 [▶ 99]</a>	<b>Subindex</b>	TC RxPDO-Map Outputs Ch.4	RO	0x01 (1 <sub>dec</sub> )
	1603:01	SubIndex 001	RO	0x7030:11, 16
<a href="#">1A00:0 [▶ 99]</a>	<b>Subindex</b>	TC TxPDO-Map TCInputs Ch.1	RO	0x0A (10 <sub>dec</sub> )
	1A00:01	SubIndex 001	RO	0x6000:01, 1
	1A00:02	SubIndex 002	RO	0x6000:02, 1
	1A00:03	SubIndex 003	RO	0x6000:03, 2
	1A00:04	SubIndex 004	RO	0x6000:05, 2
	1A00:05	SubIndex 005	RO	0x6000:07, 1
	1A00:06	SubIndex 006	RO	0x0000:00, 6
	1A00:07	SubIndex 007	RO	0x6000:0E, 1
	1A00:08	SubIndex 008	RO	0x1800:07, 1
	1A00:09	SubIndex 009	RO	0x1800:09, 1
	1A00:0A	SubIndex 010	RO	0x6000:11, 16

Index (hex)		Name	Flags	Default value
1A01:0 [▶ 100]	<b>Subindex</b>	TC TxPDO-Map TCInputs Ch.2	RO	0x0A (10 <sub>dec</sub> )
	1A01:01	SubIndex 001	RO	0x6010:01, 1
	1A01:02	SubIndex 002	RO	0x6010:02, 1
	1A01:03	SubIndex 003	RO	0x6010:03, 2
	1A01:04	SubIndex 004	RO	0x6010:05, 2
	1A01:05	SubIndex 005	RO	0x6010:07, 1
	1A01:06	SubIndex 006	RO	0x0000:00, 6
	1A01:07	SubIndex 007	RO	0x6010:0E, 1
	1A01:08	SubIndex 008	RO	0x1801:07, 1
	1A01:09	SubIndex 009	RO	0x1801:09, 1
	1A01:0A	SubIndex 010	RO	0x6010:11, 16
1A02:0 [▶ 100]	<b>Subindex</b>	TC TxPDO-Map TCInputs Ch.3	RO	0x0A (10 <sub>dec</sub> )
	1A02:01	SubIndex 001	RO	0x6020:01, 1
	1A02:02	SubIndex 002	RO	0x6020:02, 1
	1A02:03	SubIndex 003	RO	0x6020:03, 2
	1A02:04	SubIndex 004	RO	0x6020:05, 2
	1A02:05	SubIndex 005	RO	0x6020:07, 1
	1A02:06	SubIndex 006	RO	0x0000:00, 6
	1A02:07	SubIndex 007	RO	0x6020:0E, 1
	1A02:08	SubIndex 008	RO	0x1802:07, 1
	1A02:09	SubIndex 009	RO	0x1802:09, 1
	1A02:0A	SubIndex 010	RO	0x6020:11, 16
1A03:0 [▶ 101]	<b>Subindex</b>	TC TxPDO-Map TCInputs Ch.4	RO	0x0A (10 <sub>dec</sub> )
	1A03:01	SubIndex 001	RO	0x6030:01, 1
	1A03:02	SubIndex 002	RO	0x6030:02, 1
	1A03:03	SubIndex 003	RO	0x6030:03, 2
	1A03:04	SubIndex 004	RO	0x6030:05, 2
	1A03:05	SubIndex 005	RO	0x6030:07, 1
	1A03:06	SubIndex 006	RO	0x0000:00, 6
	1A03:07	SubIndex 007	RO	0x6030:0E, 1
	1A03:08	SubIndex 008	RO	0x1803:07, 1
	1A03:09	SubIndex 009	RO	0x1803:09, 1
	1A03:0A	SubIndex 010	RO	0x6030:11, 16
1C00:0 [▶ 101]	<b>Subindex</b>	Sync manager type	RO	0x04 (4 <sub>dec</sub> )
	1C00:01	SubIndex 001	RO	0x01 (1 <sub>dec</sub> )
	1C00:02	SubIndex 002	RO	0x02 (2 <sub>dec</sub> )
	1C00:03	SubIndex 003	RO	0x03 (3 <sub>dec</sub> )
	1C00:04	SubIndex 004	RO	0x04 (4 <sub>dec</sub> )

Index (hex)	Name	Flags	Default value
1C12:0 [▶ 101]	<b>Subindex</b>	RxPDO assign	RW 0x00 (0 <sub>dec</sub> )
	1C12:01	SubIndex 001	RW 0x0000 (0 <sub>dec</sub> )
	1C12:02	SubIndex 002	RW 0x0000 (0 <sub>dec</sub> )
	1C12:03	SubIndex 003	RW 0x0000 (0 <sub>dec</sub> )
	1C12:04	SubIndex 004	RW 0x0000 (0 <sub>dec</sub> )
1C13:0 [▶ 101]	<b>Subindex</b>	TxPDO assign	RW 0x04 (4 <sub>dec</sub> )
	1C13:01	SubIndex 001	RW 0x1A00 (6656 <sub>dec</sub> )
	1C13:02	SubIndex 002	RW 0x1A01 (6657 <sub>dec</sub> )
	1C13:03	SubIndex 003	RW 0x1A02 (6658 <sub>dec</sub> )
	1C13:04	SubIndex 004	RW 0x1A03 (6659 <sub>dec</sub> )
1C32:0 [▶ 102]	<b>Subindex</b>	SM output parameter	RO 0x20 (32 <sub>dec</sub> )
	1C32:01	Sync mode	RW 0x0000 (0 <sub>dec</sub> )
	1C32:02	Cycle time	RW 0x000F4240 (1000000 <sub>dec</sub> )
	1C32:03	Shift time	RO 0x00000000 (0 <sub>dec</sub> )
	1C32:04	Sync modes supported	RO 0xC007 (49159 <sub>dec</sub> )
	1C32:05	Minimum cycle time	RO 0x00002710 (10000 <sub>dec</sub> )
	1C32:06	Calc and copy time	RO 0x00000000 (0 <sub>dec</sub> )
	1C32:07	Minimum delay time	RO 0x00000000 (0 <sub>dec</sub> )
	1C32:08	Command	RW 0x0000 (0 <sub>dec</sub> )
	1C32:09	Maximum Delay time	RO 0x00000000 (0 <sub>dec</sub> )
	1C32:0B	SM event missed counter	RO 0x0000 (0 <sub>dec</sub> )
	1C32:0C	Cycle exceeded counter	RO 0x0000 (0 <sub>dec</sub> )
	1C32:0D	Shift too short counter	RO 0x0000 (0 <sub>dec</sub> )
	1C32:20	Sync error	RO 0x00 (0 <sub>dec</sub> )
1C33:0 [▶ 103]	<b>Subindex</b>	SM input parameter	RO 0x20 (32 <sub>dec</sub> )
	1C33:01	Sync mode	RW 0x0000 (0 <sub>dec</sub> )
	1C33:02	Cycle time	RW 0x000F4240 (1000000 <sub>dec</sub> )
	1C33:03	Shift time	RO 0x00000000 (0 <sub>dec</sub> )
	1C33:04	Sync modes supported	RO 0xC007 (49159 <sub>dec</sub> )
	1C33:05	Minimum cycle time	RO 0x00002710 (10000 <sub>dec</sub> )
	1C33:06	Calc and copy time	RO 0x00000000 (0 <sub>dec</sub> )
	1C33:07	Minimum delay time	RO 0x00000000 (0 <sub>dec</sub> )
	1C33:08	Command	RW 0x0000 (0 <sub>dec</sub> )
	1C33:09	Maximum Delay time	RO 0x00000000 (0 <sub>dec</sub> )
	1C33:0B	SM event missed counter	RO 0x0000 (0 <sub>dec</sub> )
	1C33:0C	Cycle exceeded counter	RO 0x0000 (0 <sub>dec</sub> )
	1C33:0D	Shift too short counter	RO 0x0000 (0 <sub>dec</sub> )
	1C33:20	Sync error	RO 0x00 (0 <sub>dec</sub> )
6000:0 [▶ 104]	<b>Subindex</b>	TC Inputs Ch.1	RO 0x11 (17 <sub>dec</sub> )
	6000:01	Underrange	RO 0x00 (0 <sub>dec</sub> )
	6000:02	Overrange	RO 0x00 (0 <sub>dec</sub> )
	6000:03	Limit 1	RO 0x00 (0 <sub>dec</sub> )
	6000:05	Limit 2	RO 0x00 (0 <sub>dec</sub> )
	6000:07	Error	RO 0x00 (0 <sub>dec</sub> )
	6000:0E	Sync error	RO 0x00 (0 <sub>dec</sub> )
	6000:0F	TxPDO State	RO 0x00 (0 <sub>dec</sub> )
	6000:10	TxPDO Toggle	RO 0x00 (0 <sub>dec</sub> )
	6000:11	Value	RO 0x0000 (0 <sub>dec</sub> )

Index (hex)		Name	Flags	Default value
6010:0 [▶ 104]	<b>Subindex</b>	TC Inputs Ch.2	RO	0x11 (17 <sub>dec</sub> )
	6010:01	Underrange	RO	0x00 (0 <sub>dec</sub> )
	6010:02	Overrange	RO	0x00 (0 <sub>dec</sub> )
	6010:03	Limit 1	RO	0x00 (0 <sub>dec</sub> )
	6010:05	Limit 2	RO	0x00 (0 <sub>dec</sub> )
	6010:07	Error	RO	0x00 (0 <sub>dec</sub> )
	6010:0E	Sync error	RO	0x00 (0 <sub>dec</sub> )
	6010:0F	TxPDO State	RO	0x00 (0 <sub>dec</sub> )
	6010:10	TxPDO Toggle	RO	0x00 (0 <sub>dec</sub> )
6010:11	Value	RO	0x0000 (0 <sub>dec</sub> )	
6020:0 [▶ 105]	<b>Subindex</b>	TC Inputs Ch.3	RO	0x11 (17 <sub>dec</sub> )
	6020:01	Underrange	RO	0x00 (0 <sub>dec</sub> )
	6020:02	Overrange	RO	0x00 (0 <sub>dec</sub> )
	6020:03	Limit 1	RO	0x00 (0 <sub>dec</sub> )
	6020:05	Limit 2	RO	0x00 (0 <sub>dec</sub> )
	6020:07	Error	RO	0x00 (0 <sub>dec</sub> )
	6020:0E	Sync error	RO	0x00 (0 <sub>dec</sub> )
	6020:0F	TxPDO State	RO	0x00 (0 <sub>dec</sub> )
	6020:10	TxPDO Toggle	RO	0x00 (0 <sub>dec</sub> )
6020:11	Value	RO	0x0000 (0 <sub>dec</sub> )	
6030:0 [▶ 105]	<b>Subindex</b>	TC Inputs Ch.4	RO	0x11 (17 <sub>dec</sub> )
	6030:01	Underrange	RO	0x00 (0 <sub>dec</sub> )
	6030:02	Overrange	RO	0x00 (0 <sub>dec</sub> )
	6030:03	Limit 1	RO	0x00 (0 <sub>dec</sub> )
	6030:05	Limit 2	RO	0x00 (0 <sub>dec</sub> )
	6030:07	Error	RO	0x00 (0 <sub>dec</sub> )
	6030:0E	Sync error	RO	0x00 (0 <sub>dec</sub> )
	6030:0F	TxPDO State	RO	0x00 (0 <sub>dec</sub> )
	6030:10	TxPDO Toggle	RO	0x00 (0 <sub>dec</sub> )
6030:11	Value	RO	0x0000 (0 <sub>dec</sub> )	
7000:0 [▶ 106]	<b>Subindex</b>	TC Outputs Ch.1	RO	0x11 (17 <sub>dec</sub> )
7000:11	CJCompensation	RO	0x0000 (0 <sub>dec</sub> )	
7010:0 [▶ 106]	<b>Subindex</b>	TC Outputs Ch.2	RO	0x11 (17 <sub>dec</sub> )
7010:11	CJCompensation	RO	0x0000 (0 <sub>dec</sub> )	
7020:0 [▶ 106]	<b>Subindex</b>	TC Outputs Ch.3	RO	0x11 (17 <sub>dec</sub> )
7020:11	CJCompensation	RO	0x0000 (0 <sub>dec</sub> )	
7030:0 [▶ 106]	<b>Subindex</b>	TC Outputs Ch.4	RO	0x11 (17 <sub>dec</sub> )
7030:11	CJCompensation	RO	0x0000 (0 <sub>dec</sub> )	



Index (hex)	Name	Flags	Default value
8000:0 [▶ 93]	<b>Subindex</b> TC Settings Ch.1	RW	0x1B (27 <sub>dec</sub> )
8000:01	Enable user scale	RW	0x00 (0 <sub>dec</sub> )
8000:02	Presentation	RW	0x00 (0 <sub>dec</sub> )
8000:05	Siemens bits	RW	0x00 (0 <sub>dec</sub> )
8000:06	Enable filter	RW	0x00 (0 <sub>dec</sub> )
8000:07	Enable limit 1	RW	0x00 (0 <sub>dec</sub> )
8000:08	Enable limit 2	RW	0x00 (0 <sub>dec</sub> )
8000:0A	Enable user calibration	RW	0x00 (0 <sub>dec</sub> )
8000:0B	Enable vendor calibration	RW	0x01 (1 <sub>dec</sub> )
8000:0C	Coldjunction compensation	RW	0x00 (0 <sub>dec</sub> )
8000:0E	Swap limit bits	RW	0x00 (0 <sub>dec</sub> )
8000:11	User scale offset	RW	0x0000 (0 <sub>dec</sub> )
8000:12	User scale gain	RW	0x00010000 (65536 <sub>dec</sub> )
8000:13	Limit 1	RW	0x0000 (0 <sub>dec</sub> )
8000:14	Limit 2	RW	0x0000 (0 <sub>dec</sub> )
8000:15	Filter settings	RW	0x0000 (0 <sub>dec</sub> )
8000:16	Calibration interval	RW	0x0000 (0 <sub>dec</sub> )
8000:17	User calibration offset	RW	0x0000 (0 <sub>dec</sub> )
8000:18	User calibration gain	RW	0x4000 (16384 <sub>dec</sub> )
8000:19	Sensor type	RW	0x0000 (0 <sub>dec</sub> )
8000:1B	Wire calibration 1/32 Ohm	RW	0x0000 (0 <sub>dec</sub> )
800E:0 [▶ 106]	<b>Subindex</b> TC Internal data Ch.1	RO	0x05 (5 <sub>dec</sub> )
800E:01	ADC raw value TC	RO	0x00000000 (0 <sub>dec</sub> )
800E:02	ADC raw value PT1000	RO	0x00000000 (0 <sub>dec</sub> )
800E:03	CJ temperature	RO	0x0000 (0 <sub>dec</sub> )
800E:04	CJ voltage	RO	0x0000 (0 <sub>dec</sub> )
800E:05	CJ resistor	RO	0x0000 (0 <sub>dec</sub> )
800F:0 [▶ 106]	<b>Subindex</b> TC Vendor data Ch.1	RW	0x04 (4 <sub>dec</sub> )
800F:01	Calibration offset TC	RW	0x0000 (0 <sub>dec</sub> )
800F:02	Calibration gain TC	RW	0x4000 (16384 <sub>dec</sub> )
800F:03	Calibration offset CJ	RW	0x0000 (0 <sub>dec</sub> )
800F:04	Calibration gain CJ	RW	0x4000 (16384 <sub>dec</sub> )
8010:0 [▶ 94]	<b>Subindex</b> TC Settings Ch.2	RW	0x1B (27 <sub>dec</sub> )
8010:01	Enable user scale	RW	0x00 (0 <sub>dec</sub> )
8010:02	Presentation	RW	0x00 (0 <sub>dec</sub> )
8010:05	Siemens bits	RW	0x00 (0 <sub>dec</sub> )
8010:06	Enable filter	RW	0x00 (0 <sub>dec</sub> )
8010:07	Enable limit 1	RW	0x00 (0 <sub>dec</sub> )
8010:08	Enable limit 2	RW	0x00 (0 <sub>dec</sub> )
8010:0A	Enable user calibration	RW	0x00 (0 <sub>dec</sub> )
8010:0B	Enable vendor calibration	RW	0x01 (1 <sub>dec</sub> )
8010:0C	Coldjunction compensation	RW	0x00 (0 <sub>dec</sub> )
8010:0E	Swap limit bits	RW	0x00 (0 <sub>dec</sub> )
8010:11	User scale offset	RW	0x0000 (0 <sub>dec</sub> )
8010:12	User scale gain	RW	0x00010000 (65536 <sub>dec</sub> )
8010:13	Limit 1	RW	0x0000 (0 <sub>dec</sub> )
8010:14	Limit 2	RW	0x0000 (0 <sub>dec</sub> )
8010:15	Filter settings	RW	0x0000 (0 <sub>dec</sub> )
8010:16	Calibration interval	RW	0x0000 (0 <sub>dec</sub> )
8010:17	User calibration offset	RW	0x0000 (0 <sub>dec</sub> )
8010:18	User calibration gain	RW	0x4000 (16384 <sub>dec</sub> )
8010:19	Sensor type	RW	0x0000 (0 <sub>dec</sub> )
8010:1B	Wire calibration 1/32 Ohm	RW	0x0000 (0 <sub>dec</sub> )

Index (hex)		Name	Flags	Default value
801E:0 [▶ 107]	<b>Subindex</b>	TC Internal data Ch.2	RO	0x05 (5 <sub>dec</sub> )
	801E:01	ADC raw value TC	RO	0x00000000 (0 <sub>dec</sub> )
	801E:02	ADC raw value PT1000	RO	0x00000000 (0 <sub>dec</sub> )
	801E:03	CJ temperature	RO	0x0000 (0 <sub>dec</sub> )
	801E:04	CJ voltage	RO	0x0000 (0 <sub>dec</sub> )
	801E:05	CJ resistor	RO	0x0000 (0 <sub>dec</sub> )
801F:0 [▶ 107]	<b>Subindex</b>	TC Vendor data Ch.2	RW	0x04 (4 <sub>dec</sub> )
	801F:01	Calibration offset TC	RW	0x0000 (0 <sub>dec</sub> )
	801F:02	Calibration gain TC	RW	0x4000 (16384 <sub>dec</sub> )
	801F:03	Calibration offset CJ	RW	0x0000 (0 <sub>dec</sub> )
	801F:04	Calibration gain CJ	RW	0x4000 (16384 <sub>dec</sub> )
8020:0 [▶ 95]	<b>Subindex</b>	TC Settings Ch.3	RW	0x1B (27 <sub>dec</sub> )
	8020:01	Enable user scale	RW	0x00 (0 <sub>dec</sub> )
	8020:02	Presentation	RW	0x00 (0 <sub>dec</sub> )
	8020:05	Siemens bits	RW	0x00 (0 <sub>dec</sub> )
	8020:06	Enable filter	RW	0x00 (0 <sub>dec</sub> )
	8020:07	Enable limit 1	RW	0x00 (0 <sub>dec</sub> )
	8020:08	Enable limit 2	RW	0x00 (0 <sub>dec</sub> )
	8020:0A	Enable user calibration	RW	0x00 (0 <sub>dec</sub> )
	8020:0B	Enable vendor calibration	RW	0x01 (1 <sub>dec</sub> )
	8020:0C	Coldjunction compensation	RW	0x00 (0 <sub>dec</sub> )
	8020:0E	Swap limit bits	RW	0x00 (0 <sub>dec</sub> )
	8020:11	User scale offset	RW	0x0000 (0 <sub>dec</sub> )
	8020:12	User scale gain	RW	0x00010000 (65536 <sub>dec</sub> )
	8020:13	Limit 1	RW	0x0000 (0 <sub>dec</sub> )
	8020:14	Limit 2	RW	0x0000 (0 <sub>dec</sub> )
	8020:15	Filter settings	RW	0x0000 (0 <sub>dec</sub> )
	8020:16	Calibration interval	RW	0x0000 (0 <sub>dec</sub> )
	8020:17	User calibration offset	RW	0x0000 (0 <sub>dec</sub> )
	8020:18	User calibration gain	RW	0x4000 (16384 <sub>dec</sub> )
	8020:19	Sensor type	RW	0x0000 (0 <sub>dec</sub> )
	8020:1B	Wire calibration 1/32 Ohm	RW	0x0000 (0 <sub>dec</sub> )
802E:0 [▶ 107]	<b>Subindex</b>	TC Internal data Ch.3	RO	0x05 (5 <sub>dec</sub> )
	802E:01	ADC raw value TC	RO	0x00000000 (0 <sub>dec</sub> )
	802E:02	ADC raw value PT1000	RO	0x00000000 (0 <sub>dec</sub> )
	802E:03	CJ temperature	RO	0x0000 (0 <sub>dec</sub> )
	802E:04	CJ voltage	RO	0x0000 (0 <sub>dec</sub> )
	802E:05	CJ resistor	RO	0x0000 (0 <sub>dec</sub> )
802F:0 [▶ 107]	<b>Subindex</b>	TC Vendor data Ch.3	RW	0x04 (4 <sub>dec</sub> )
	802F:01	Calibration offset TC	RW	0x0000 (0 <sub>dec</sub> )
	802F:02	Calibration gain TC	RW	0x4000 (16384 <sub>dec</sub> )
	802F:03	Calibration offset CJ	RW	0x0000 (0 <sub>dec</sub> )
	802F:04	Calibration gain CJ	RW	0x4000 (16384 <sub>dec</sub> )

Index (hex)	Name	Flags	Default value
8030:0 [▶ 97]	<b>Subindex</b> TC Settings Ch.4	RW	0x1B (27 <sub>dec</sub> )
	8030:01 Enable user scale	RW	0x00 (0 <sub>dec</sub> )
	8030:02 Presentation	RW	0x00 (0 <sub>dec</sub> )
	8030:05 Siemens bits	RW	0x00 (0 <sub>dec</sub> )
	8030:06 Enable filter	RW	0x00 (0 <sub>dec</sub> )
	8030:07 Enable limit 1	RW	0x00 (0 <sub>dec</sub> )
	8030:08 Enable limit 2	RW	0x00 (0 <sub>dec</sub> )
	8030:0A Enable user calibration	RW	0x00 (0 <sub>dec</sub> )
	8030:0B Enable vendor calibration	RW	0x01 (1 <sub>dec</sub> )
	8030:0C Coldjunction compensation	RW	0x00 (0 <sub>dec</sub> )
	8030:0E Swap limit bits	RW	0x00 (0 <sub>dec</sub> )
	8030:11 User scale offset	RW	0x0000 (0 <sub>dec</sub> )
	8030:12 User scale gain	RW	0x00010000 (65536 <sub>dec</sub> )
	8030:13 Limit 1	RW	0x0000 (0 <sub>dec</sub> )
	8030:14 Limit 2	RW	0x0000 (0 <sub>dec</sub> )
	8030:15 Filter settings	RW	0x0000 (0 <sub>dec</sub> )
	8030:16 Calibration interval	RW	0x0000 (0 <sub>dec</sub> )
	8030:17 User calibration offset	RW	0x0000 (0 <sub>dec</sub> )
	8030:18 User calibration gain	RW	0x4000 (16384 <sub>dec</sub> )
	8030:19 Sensor type	RW	0x0000 (0 <sub>dec</sub> )
	8030:1B Wire calibration 1/32 Ohm	RW	0x0000 (0 <sub>dec</sub> )
803E:0 [▶ 107]	<b>Subindex</b> TC Internal data Ch.4	RO	0x05 (5 <sub>dec</sub> )
	803E:01 ADC raw value TC	RO	0x00000000 (0 <sub>dec</sub> )
	803E:02 ADC raw value PT1000	RO	0x00000000 (0 <sub>dec</sub> )
	803E:03 CJ temperature	RO	0x0000 (0 <sub>dec</sub> )
	803E:04 CJ voltage	RO	0x0000 (0 <sub>dec</sub> )
	803E:05 CJ resistor	RO	0x0000 (0 <sub>dec</sub> )
803F:0 [▶ 108]	<b>Subindex</b> TC Vendor data Ch.4	RW	0x04 (4 <sub>dec</sub> )
	803F:01 Calibration offset TC	RW	0x0000 (0 <sub>dec</sub> )
	803F:02 Calibration gain TC	RW	0x4000 (16384 <sub>dec</sub> )
	803F:03 Calibration offset CJ	RW	0x0000 (0 <sub>dec</sub> )
	803F:04 Calibration gain CJ	RW	0x4000 (16384 <sub>dec</sub> )
F000:0 [▶ 108]	<b>Subindex</b> Modular device profile	RO	0x02 (2 <sub>dec</sub> )
	F000:01 Module index distance	RO	0x0010 (16 <sub>dec</sub> )
	F000:02 Maximum number of modules	RO	0x0004 (4 <sub>dec</sub> )
F008 [▶ 108]	Code word	RW	0x00000000 (0 <sub>dec</sub> )
F010:0 [▶ 108]	<b>Subindex</b> Module list	RW	0x04 (4 <sub>dec</sub> )
	F010:01 SubIndex 001	RW	0x0000014A (330 <sub>dec</sub> )
	F010:02 SubIndex 002	RW	0x0000014A (330 <sub>dec</sub> )
	F010:03 SubIndex 003	RW	0x0000014A (330 <sub>dec</sub> )
	F010:04 SubIndex 004	RW	0x0000014A (330 <sub>dec</sub> )
F080:0 [▶ 108]	<b>Subindex</b> Channel Enable	RO	0x04 (4 <sub>dec</sub> )
	F080:01 SubIndex 001	RW	0xFF (255 <sub>dec</sub> )
	F080:02 SubIndex 002	RW	0xFF (255 <sub>dec</sub> )
	F080:03 SubIndex 003	RW	0xFF (255 <sub>dec</sub> )
	F080:04 SubIndex 004	RW	0xFF (255 <sub>dec</sub> )

**Key**

Flags:

RO (Read Only): this object can be read only

RW (Read/Write): this object can be read and written to

## 6.7 EP3314 - object description and parameterization

### ● Parameterization

You can parameterize the box via the "CoE - Online" tab in TwinCAT.

### ● EtherCAT XML Device Description

The presentation matches that of the EtherCAT XML Device Description.

Recommendation: download the latest XML file from <https://www.beckhoff.com/> and install it according to the installation instructions.

### Introduction

The CoE overview contains objects for different intended applications:

- Objects required for parameterization during commissioning
- Objects intended for regular operation [▶ 98], e.g. through ADS access
- Objects for indicating internal settings [▶ 92] (may be fixed)
- Further profile-specific objects [▶ 104] indicating inputs, outputs and status information

The following section first describes the objects required for normal operation, followed by a complete overview of missing objects.

### 6.7.1 Objects to be parameterized during commissioning

#### Index 1011: Restore default parameters

Index (hex)	Name	Meaning	Data type	Flags	Default
1011:0	Restore default parameters	Restore default parameters	UINT8	RO	0x01 (1 <sub>dec</sub> )
1011:01	SubIndex 001	If this object is set to "0x64616F6C" in the set value dialog, all backup objects are reset to their delivery state.	UINT32	RW	0x00000000 (0 <sub>dec</sub> )

**Index 8000: TC Settings Ch.1**

Index (hex)	Name	Meaning	Data type	Flags	Default	
8000:0	TC Settings Ch.1	Maximum subindex	UINT8	RO	0x1B (27 <sub>dec</sub> )	
8000:01	Enable user scale	Activates user scaling	BOOLEAN	RW	0x00 (0 <sub>dec</sub> )	
8000:02	Presentation	Presentation of the measured value		BIT3	RW	0x00 (0 <sub>dec</sub> )
		0	Signed, in two's complement			
		1	Most significant bit as sign			
		2	High-resolution (1/100 °C steps)			
8000:05	Siemens bits	The S5 bits are displayed in the three low-order bits	BOOLEAN	RW	0x00 (0 <sub>dec</sub> )	
8000:06	Enable filter	This parameter is without effect. The filter is always enabled.	BOOLEAN	RW	0x00 (0 <sub>dec</sub> )	
8000:07	Enable limit 1	Activates limit check for limit 1	BOOLEAN	RW	0x00 (0 <sub>dec</sub> )	
8000:08	Enable limit 2	Activates limit check for limit 2	BOOLEAN	RW	0x00 (0 <sub>dec</sub> )	
8000:0A	Enable user calibration	Activates user calibration	BOOLEAN	RW	0x00 (0 <sub>dec</sub> )	
8000:0B	Enable vendor calibration	Activates vendor calibration	BOOLEAN	RW	0x01 (1 <sub>dec</sub> )	
8000:0C	Cold junction compensation	Cold junction compensation		BIT2	RW	0x00 (0 <sub>dec</sub> )
		0	Cold junction compensation takes place via the Pt1000 in the plug connector.			
		1	Cold junction compensation is not active.			
		2	Cold junction compensation takes place via the process data.			
		3	Same as value 0.			
8000:0E	Swap limit bits	Swaps the two limit bits, in order to achieve compatibility with older hardware versions.	BOOLEAN	RW	0x00 (0 <sub>dec</sub> )	
8000:11	User scale offset	User scaling: Offset	INT16	RW	0x0000 (0 <sub>dec</sub> )	
8000:12	User scale gain	User scaling: Gain	INT32	RW	0x00010000 (65536 <sub>dec</sub> )	
8000:13	Limit 1	Value for limit 1	INT16	RW	0x0000 (0 <sub>dec</sub> )	
8000:14	Limit 2	Value for limit 2	INT16	RW	0x0000 (0 <sub>dec</sub> )	
8000:15	Filter settings	Filter settings (Ch1. applies to all channels)		UINT16	RW	0x0000 (0 <sub>dec</sub> )
		0	50 Hz			
		1	60 Hz			
		2	100 Hz			
		3	500 Hz			
		4	1 kHz,			
		5	2 kHz			
		6	3.75 kHz			
		7	7.5 kHz			
		8	15 kHz			
		9	30 kHz			
		10	5 Hz			
		11	10 Hz			
8000:16	Calibration interval	reserved	UINT16	RW	0x0000 (0 <sub>dec</sub> )	
8000:17	User calibration offset	User calibration: Offset	INT16	RW	0x0000 (0 <sub>dec</sub> )	
8000:18	User calibration gain	User calibration: Gain	UINT16	RW	0x4000 (16384 <sub>dec</sub> )	

## Index 8000: TC Settings Ch.1

Index (hex)	Name	Meaning	Data type	Flags	Default	
8000:19	Sensor type	Thermocouple	UINT16	RW	0x0000 (0 <sub>dec</sub> )	
		0				Type K -200 °C to 1370 °C
		1				Type J -100°C to 1200°C
		2				Type L 0°C to 900°C
		3				Type E -100°C to 1000°C
		4				Type T -200°C to 400°C
		5				Type N -100°C to 1300°C
		6				Type U 0°C to 600°C
		7				Type B 600°C to 1800°C
		8				Type R 0°C to 1767°C
		9				Type S 0°C to 1760°C
		10				Type C 0°C to 2320°C
		100				± 30 mV (1 µV resolution)
101	± 60 mV (2 µV resolution)					
102	± 75 mV (4 µV resolution)					
8000:1B	Wire calibration 1/32 ohm	Only for 2-wire measurements: contains the resistance of the supply line for the temperature sensor (in 1/32 ohm).	INT16	RW	0x0000 (0 <sub>dec</sub> )	

## Index 8010: TC Settings Ch.2

Index (hex)	Name	Meaning	Data type	Flags	Default	
8010:0	TC Settings Ch.2	Maximum subindex	UINT8	RO	0x1B (27 <sub>dec</sub> )	
8010:01	Enable user scale	Activates user scaling	BOOLEAN	RW	0x00 (0 <sub>dec</sub> )	
8010:02	Presentation	Presentation of the measured value	BIT3	RW	0x00 (0 <sub>dec</sub> )	
		0				Signed, in two's complement
		1				Most significant bit as sign
2	High-resolution (1/100 °C steps)					
8010:05	Siemens bits	The S5 bits are displayed in the three low-order bits	BOOLEAN	RW	0x00 (0 <sub>dec</sub> )	
8010:06	Enable filter	This parameter is without effect. The filter is always enabled.	BOOLEAN	RW	0x00 (0 <sub>dec</sub> )	
8010:07	Enable limit 1	Activates limit check for limit 1	BOOLEAN	RW	0x00 (0 <sub>dec</sub> )	
8010:08	Enable limit 2	Activates limit check for limit 2	BOOLEAN	RW	0x00 (0 <sub>dec</sub> )	
8010:0A	Enable user calibration	Activates user calibration	BOOLEAN	RW	0x00 (0 <sub>dec</sub> )	
8010:0B	Enable vendor calibration	Activates vendor calibration	BOOLEAN	RW	0x01 (1 <sub>dec</sub> )	
8010:0C	Cold junction compensation	Cold junction compensation	BIT2	RW	0x00 (0 <sub>dec</sub> )	
		0				Cold junction compensation takes place via the Pt1000 in the plug connector.
		1				Cold junction compensation is not active.
		2				Cold junction compensation takes place via the process data.
3	Cold junction compensation takes place via the Pt1000 in the plug connector of channel 1.					
8010:0E	Swap limit bits	Swaps the two limit bits, in order to achieve compatibility with older hardware versions.	BOOLEAN	RW	0x00 (0 <sub>dec</sub> )	
8010:11	User scale offset	User scaling: Offset	INT16	RW	0x0000 (0 <sub>dec</sub> )	
8010:12	User scale gain	User scaling: Gain	INT32	RW	0x00010000 (65536 <sub>dec</sub> )	
8010:13	Limit 1	Value for limit 1	INT16	RW	0x0000 (0 <sub>dec</sub> )	
8010:14	Limit 2	Value for limit 2	INT16	RW	0x0000 (0 <sub>dec</sub> )	

**Index 8010: TC Settings Ch.2**

Index (hex)	Name	Meaning	Data type	Flags	Default	
8010:15	Filter settings	This parameter is without effect. The respective parameter of channel 1 applies to all channels: 0x8000:15 "Filter settings" [► 93].	UINT16	RW	0x0000 (0 <sub>dec</sub> )	
8010:16	Calibration interval	reserved	UINT16	RW	0x0000 (0 <sub>dec</sub> )	
8010:17	User calibration offset	User calibration: Offset	INT16	RW	0x0000 (0 <sub>dec</sub> )	
8010:18	User calibration gain	User calibration: Gain	UINT16	RW	0x4000 (16384 <sub>dec</sub> )	
8010:19	Sensor type	Thermocouple	UINT16	RW	0x0000 (0 <sub>dec</sub> )	
		0				Type K -200 °C to 1370 °C
		1				Type J -100°C to 1200°C
		2				Type L 0°C to 900°C
		3				Type E -100°C to 1000°C
		4				Type T -200°C to 400°C
		5				Type N -100°C to 1300°C
		6				Type U 0°C to 600°C
		7				Type B 600°C to 1800°C
		8				Type R 0°C to 1767°C
		9				Type S 0°C to 1760°C
		10				Type C 0°C to 2320°C
		100				± 30 mV (1 µV resolution)
101	± 60 mV (2 µV resolution)					
102	± 75 mV (4 µV resolution)					
8010:1B	Wire calibration 1/32 Ohm	Only for 2-wire measurements: contains the resistance of the supply line for the temperature sensor (in 1/32 ohm).	INT16	RW	0x0000 (0 <sub>dec</sub> )	

**Index 8020: TC Settings Ch.3**

Index (hex)	Name	Meaning	Data type	Flags	Default	
8020:0	TC Settings Ch.3	Maximum subindex	UINT8	RO	0x1B (27 <sub>dec</sub> )	
8020:01	Enable user scale	Activates user scaling	BOOLEAN	RW	0x00 (0 <sub>dec</sub> )	
8020:02	Presentation	Presentation of the measured value	BIT3	RW	0x00 (0 <sub>dec</sub> )	
		0				Signed, in two's complement
		1				Most significant bit as sign
8020:05	Siemens bits	The S5 bits are displayed in the three low-order bits	BOOLEAN	RW	0x00 (0 <sub>dec</sub> )	
8020:06	Enable filter	This parameter is without effect. The filter is always enabled.	BOOLEAN	RW	0x00 (0 <sub>dec</sub> )	
8020:07	Enable limit 1	Activates limit check for limit 1	BOOLEAN	RW	0x00 (0 <sub>dec</sub> )	
8020:08	Enable limit 2	Activates limit check for limit 2	BOOLEAN	RW	0x00 (0 <sub>dec</sub> )	
8020:0A	Enable user calibration	Activates user calibration	BOOLEAN	RW	0x00 (0 <sub>dec</sub> )	
8020:0B	Enable vendor calibration	Activates vendor calibration	BOOLEAN	RW	0x01 (1 <sub>dec</sub> )	

## Index 8020: TC Settings Ch.3

Index (hex)	Name	Meaning	Data type	Flags	Default
8020:0C	Cold junction compensation	Cold junction compensation	BIT2	RW	0x00 (0 <sub>dec</sub> )
		0 Cold junction compensation takes place via the Pt1000 in the plug connector.			
		1 Cold junction compensation is not active.			
		2 Cold junction compensation takes place via the process data.			
		3 Cold junction compensation takes place via the Pt1000 in the plug connector of channel 1.			
8020:0E	Swap limit bits	Swaps the two limit bits, in order to achieve compatibility with older hardware versions.	BOOLEAN	RW	0x00 (0 <sub>dec</sub> )
8020:11	User scale offset	User scaling: Offset	INT16	RW	0x0000 (0 <sub>dec</sub> )
8020:12	User scale gain	User scaling: Gain	INT32	RW	0x00010000 (65536 <sub>dec</sub> )
8020:13	Limit 1	Value for limit 1	INT16	RW	0x0000 (0 <sub>dec</sub> )
8020:14	Limit 2	Value for limit 2	INT16	RW	0x0000 (0 <sub>dec</sub> )
8020:15	Filter settings	This parameter is without effect. The respective parameter of channel 1 applies to all channels: <a href="#">0x8000:15 "Filter settings" [► 93]</a> .	UINT16	RW	0x0000 (0 <sub>dec</sub> )
8020:16	Calibration interval	reserved	UINT16	RW	0x0000 (0 <sub>dec</sub> )
8020:17	User calibration offset	User calibration: Offset	INT16	RW	0x0000 (0 <sub>dec</sub> )
8020:18	User calibration gain	User calibration: Gain	UINT16	RW	0x4000 (16384 <sub>dec</sub> )
8020:19	Sensor type	Thermocouple	UINT16	RW	0x0000 (0 <sub>dec</sub> )
		0 Type K -200 °C to 1370 °C			
		1 Type J -100°C to 1200°C			
		2 Type L 0°C to 900°C			
		3 Type E -100°C to 1000°C			
		4 Type T -200°C to 400°C			
		5 Type N -100°C to 1300°C			
		6 Type U 0°C to 600°C			
		7 Type B 600°C to 1800°C			
		8 Type R 0°C to 1767°C			
		9 Type S 0°C to 1760°C			
		10 Type C 0°C to 2320°C			
		100 ± 30 mV (1 µV resolution)			
		101 ± 60 mV (2 µV resolution)			
102 ± 75 mV (4 µV resolution)					
8020:1B	Wire calibration 1/32 ohm	Only for 2-wire measurements: contains the resistance of the supply line for the temperature sensor (in 1/32 ohm).	INT16	RW	0x0000 (0 <sub>dec</sub> )



**Index 8030: TC Settings Ch.4**

Index (hex)	Name	Meaning	Data type	Flags	Default
8030:0	TC Settings Ch.4	Maximum subindex	UINT8	RO	0x1B (27 <sub>dec</sub> )
8030:01	Enable user scale	Activates user scaling	BOOLEAN	RW	0x00 (0 <sub>dec</sub> )
8030:02	Presentation	Presentation of the measured value	BIT3	RW	0x00 (0 <sub>dec</sub> )
		0 Signed, in two's complement			
		1 Most significant bit as sign			
		2 High-resolution (1/100 °C steps)			
8030:05	Siemens bits	The S5 bits are displayed in the three low-order bits	BOOLEAN	RW	0x00 (0 <sub>dec</sub> )
8030:06	Enable filter	This parameter is without effect. The filter is always enabled.	BOOLEAN	RW	0x00 (0 <sub>dec</sub> )
8030:07	Enable limit 1	Activates limit check for limit 1	BOOLEAN	RW	0x00 (0 <sub>dec</sub> )
8030:08	Enable limit 2	Activates limit check for limit 2	BOOLEAN	RW	0x00 (0 <sub>dec</sub> )
8030:0A	Enable user calibration	Activates user calibration	BOOLEAN	RW	0x00 (0 <sub>dec</sub> )
8030:0B	Enable vendor calibration	Activates vendor calibration	BOOLEAN	RW	0x01 (1 <sub>dec</sub> )
8030:0C	Cold junction compensation	Cold junction compensation	BIT2	RW	0x00 (0 <sub>dec</sub> )
		0 Cold junction compensation takes place via the Pt1000 in the plug connector.			
		1 Cold junction compensation is not active.			
		2 Cold junction compensation takes place via the process data.			
		3 Cold junction compensation takes place via the Pt1000 in the plug connector of channel 1.			
8030:0E	Swap limit bits	Swaps the two limit bits, in order to achieve compatibility with older hardware versions.	BOOLEAN	RW	0x00 (0 <sub>dec</sub> )
8030:11	User scale offset	User scaling: Offset	INT16	RW	0x0000 (0 <sub>dec</sub> )
8030:12	User scale gain	User scaling: Gain	INT32	RW	0x00010000 (65536 <sub>dec</sub> )
8030:13	Limit 1	Value for limit 1	INT16	RW	0x0000 (0 <sub>dec</sub> )
8030:14	Limit 2	Value for limit 2	INT16	RW	0x0000 (0 <sub>dec</sub> )
8030:15	Filter settings	This parameter is without effect. The respective parameter of channel 1 applies to all channels: <a href="#">0x8000:15 "Filter settings" [► 93]</a> .	UINT16	RW	0x0000 (0 <sub>dec</sub> )
8030:16	Calibration interval	reserved	UINT16	RW	0x0000 (0 <sub>dec</sub> )
8030:17	User calibration offset	User calibration: Offset	INT16	RW	0x0000 (0 <sub>dec</sub> )
8030:18	User calibration gain	User calibration: Gain	UINT16	RW	0x4000 (16384 <sub>dec</sub> )

**Index 8030: TC Settings Ch.4**

Index (hex)	Name	Meaning	Data type	Flags	Default
8030:19	Sensor type	Thermocouple	UINT16	RW	0x0000 (0 <sub>dec</sub> )
		0 Type K -200 °C to 1370 °C			
		1 Type J -100°C to 1200°C			
		2 Type L 0°C to 900°C			
		3 Type E -100°C to 1000°C			
		4 Type T -200°C to 400°C			
		5 Type N -100°C to 1300°C			
		6 Type U 0°C to 600°C			
		7 Type B 600°C to 1800°C			
		8 Type R 0°C to 1767°C			
		9 Type S 0°C to 1760°C			
		10 Type C 0°C to 2320°C			
		100 ± 30 mV (1 µV resolution)			
101 ± 60 mV (2 µV resolution)					
102 ± 75 mV (4 µV resolution)					
8030:1B	Wire calibration 1/32 ohm	Only for 2-wire measurements: contains the resistance of the supply line for the temperature sensor (in 1/32 ohm).	INT16	RW	0x0000 (0 <sub>dec</sub> )

## 6.7.2 Objects for regular operation

The EP3314 has no such objects.

## 6.7.3 Standard objects (0x1000-0x1FFF)

The standard objects have the same meaning for all EtherCAT slaves.

### Index 1000: Device type

Index (hex)	Name	Meaning	Data type	Flags	Default
1000:0	Device type	Device type of the EtherCAT slave: The Low-Word contains the CoE profile used (5001). The High-Word contains the module profile according to the modular device profile.	UINT32	RO	0x014A1389 (21631881 <sub>dec</sub> )

### Index 1008: Device name

Index (hex)	Name	Meaning	Data type	Flags	Default
1008:0	Device name	Device name of the EtherCAT slave	STRING	RO	EP3314-0002

### Index 1009: Hardware version

Index (hex)	Name	Meaning	Data type	Flags	Default
1009:0	Hardware version	Hardware version of the EtherCAT slave	STRING	RO	00

### Index 100A: Software version

Index (hex)	Name	Meaning	Data type	Flags	Default
100A:0	Software version	Firmware version of the EtherCAT slave	STRING	RO	01

### Index 1018: Identity

Index (hex)	Name	Meaning	Data type	Flags	Default
1018:0	Identity	Information for identifying the slave	UINT8	RO	0x04 (4 <sub>dec</sub> )
1018:01	Vendor ID	Vendor ID of the EtherCAT slave	UINT32	RO	0x00000002 (2 <sub>dec</sub> )
1018:02	Product code	Product code of the EtherCAT slave	UINT32	RO	0x0CF24052 (217202770 <sub>dec</sub> )
1018:03	Revision	Revision number of the EtherCAT slave; the low word (bit 0-15) indicates the special terminal number, the high word (bit 16-31) refers to the device description	UINT32	RO	0x00100002 (1048578 <sub>dec</sub> )
1018:04	Serial number	Serial number of the EtherCAT slave; the low byte (bit 0-7) of the low word contains the year of production, the high byte (bit 8-15) of the low word contains the week of production, the high word (bit 16-31) is 0	UINT32	RO	0x00000000 (0 <sub>dec</sub> )

### Index 10F0: Backup parameter handling

Index (hex)	Name	Meaning	Data type	Flags	Default
10F0:0	Backup parameter handling	Information for standardized loading and saving of backup entries	UINT8	RO	0x01 (1 <sub>dec</sub> )
10F0:01	Checksum	Checksum across all backup entries of the EtherCAT slave	UINT32	RO	0x00000000 (0 <sub>dec</sub> )

### Index 1600: TC RxPDO-Map Outputs Ch.1

Index (hex)	Name	Meaning	Data type	Flags	Default
1600:0	TC RxPDO-Map Outputs Ch.1	PDO Mapping RxPDO 1	UINT8	RO	0x01 (1 <sub>dec</sub> )
1600:01	SubIndex 001	1. PDO Mapping entry (object 0x7000 (TC Outputs Ch.1), entry 0x11 (CJCompensation))	UINT32	RO	0x7000:11, 16

**Index 1601: TC RxPDO-Map Outputs Ch.2**

Index (hex)	Name	Meaning	Data type	Flags	Default
1601:0	TC RxPDO-Map Outputs Ch.2	PDO Mapping RxPDO 2	UINT8	RO	0x01 (1 <sub>dec</sub> )
1601:01	SubIndex 001	1. PDO Mapping entry (object 0x7010 (TC Outputs Ch.2), entry 0x11 (CJCompensation))	UINT32	RO	0x7010:11, 16

**Index 1602: TC RxPDO-Map Outputs Ch.3**

Index (hex)	Name	Meaning	Data type	Flags	Default
1602:0	TC RxPDO-Map Outputs Ch.3	PDO Mapping RxPDO 3	UINT8	RO	0x01 (1 <sub>dec</sub> )
1602:01	SubIndex 001	1. PDO Mapping entry (object 0x7020 (TC Outputs Ch.3), entry 0x11 (CJCompensation))	UINT32	RO	0x7020:11, 16

**Index 1603: TC RxPDO-Map Outputs Ch.4**

Index (hex)	Name	Meaning	Data type	Flags	Default
1603:0	TC RxPDO-Map Outputs Ch.4	PDO Mapping RxPDO 4	UINT8	RO	0x01 (1 <sub>dec</sub> )
1603:01	SubIndex 001	1. PDO Mapping entry (object 0x7030 (TC Outputs Ch.4), entry 0x11 (CJCompensation))	UINT32	RO	0x7030:11, 16

**Index 1A00: TC TxPDO-Map TCInputs Ch.1**

Index (hex)	Name	Meaning	Data type	Flags	Default
1A00:0	TC TxPDO-Map TCInputs Ch.1	PDO Mapping TxPDO 1	UINT8	RO	0x0A (10 <sub>dec</sub> )
1A00:01	SubIndex 001	1. PDO Mapping entry (object 0x6000 (TC Inputs Ch.1), entry 0x01 (Underrange))	UINT32	RO	0x6000:01, 1
1A00:02	SubIndex 002	2. PDO Mapping entry (object 0x6000 (TC Inputs Ch.1), entry 0x02 (Overrange))	UINT32	RO	0x6000:02, 1
1A00:03	SubIndex 003	3. PDO Mapping entry (object 0x6000 (TC Inputs Ch.1), entry 0x03 (Limit 1))	UINT32	RO	0x6000:03, 2
1A00:04	SubIndex 004	4. PDO Mapping entry (object 0x6000 (TC Inputs Ch.1), entry 0x05 (Limit 2))	UINT32	RO	0x6000:05, 2
1A00:05	SubIndex 005	5. PDO Mapping entry (object 0x6000 (TC Inputs Ch.1), entry 0x07 (Error))	UINT32	RO	0x6000:07, 1
1A00:06	SubIndex 006	6. PDO Mapping entry (6 bits align)	UINT32	RO	0x0000:00, 6
1A00:07	SubIndex 007	7. PDO Mapping entry (object 0x6000 (TC Inputs Ch.1), entry 0x0E (Sync error))	UINT32	RO	0x6000:0E, 1
1A00:08	SubIndex 008	8. PDO Mapping entry (object 0x1800, entry 0x07)	UINT32	RO	0x1800:07, 1
1A00:09	SubIndex 009	9. PDO Mapping entry (object 0x1800, entry 0x09)	UINT32	RO	0x1800:09, 1
1A00:0A	SubIndex 010	10. PDO Mapping entry (object 0x6000 (TC Inputs Ch.1), entry 0x11 (Value))	UINT32	RO	0x6000:11, 16

**Index 1A01: TC TxPDO-Map TCInputs Ch.2**

Index (hex)	Name	Meaning	Data type	Flags	Default
1A01:0	TC TxPDO-Map TCInputs Ch.2	PDO Mapping TxPDO 2	UINT8	RO	0x0A (10 <sub>dec</sub> )
1A01:01	SubIndex 001	1. PDO Mapping entry (object 0x6010 (TC Inputs Ch.2), entry 0x01 (Underrange))	UINT32	RO	0x6010:01, 1
1A01:02	SubIndex 002	2. PDO Mapping entry (object 0x6010 (TC Inputs Ch.2), entry 0x02 (Overrange))	UINT32	RO	0x6010:02, 1
1A01:03	SubIndex 003	3. PDO Mapping entry (object 0x6010 (TC Inputs Ch.2), entry 0x03 (Limit 1))	UINT32	RO	0x6010:03, 2
1A01:04	SubIndex 004	4. PDO Mapping entry (object 0x6010 (TC Inputs Ch.2), entry 0x05 (Limit 2))	UINT32	RO	0x6010:05, 2
1A01:05	SubIndex 005	5. PDO Mapping entry (object 0x6010 (TC Inputs Ch.2), entry 0x07 (Error))	UINT32	RO	0x6010:07, 1
1A01:06	SubIndex 006	6. PDO Mapping entry (6 bits align)	UINT32	RO	0x0000:00, 6
1A01:07	SubIndex 007	7. PDO Mapping entry (object 0x6010 (TC Inputs Ch.2), entry 0x0E (Sync error))	UINT32	RO	0x6010:0E, 1
1A01:08	SubIndex 008	8. PDO Mapping entry (object 0x1801, entry 0x07)	UINT32	RO	0x1801:07, 1
1A01:09	SubIndex 009	9. PDO Mapping entry (object 0x1801, entry 0x09)	UINT32	RO	0x1801:09, 1
1A01:0A	SubIndex 010	10. PDO Mapping entry (object 0x6010 (TC Inputs Ch.2), entry 0x11 (Value))	UINT32	RO	0x6010:11, 16

**Index 1A02: TC TxPDO-Map TCInputs Ch.3**

Index (hex)	Name	Meaning	Data type	Flags	Default
1A02:0	TC TxPDO-Map TCInputs Ch.3	PDO Mapping TxPDO 3	UINT8	RO	0x0A (10 <sub>dec</sub> )
1A02:01	SubIndex 001	1. PDO Mapping entry (object 0x6020 (TC Inputs Ch.3), entry 0x01 (Underrange))	UINT32	RO	0x6020:01, 1
1A02:02	SubIndex 002	2. PDO Mapping entry (object 0x6020 (TC Inputs Ch.3), entry 0x02 (Overrange))	UINT32	RO	0x6020:02, 1
1A02:03	SubIndex 003	3. PDO Mapping entry (object 0x6020 (TC Inputs Ch.3), entry 0x03 (Limit 1))	UINT32	RO	0x6020:03, 2
1A02:04	SubIndex 004	4. PDO Mapping entry (object 0x6020 (TC Inputs Ch.3), entry 0x05 (Limit 2))	UINT32	RO	0x6020:05, 2
1A02:05	SubIndex 005	5. PDO Mapping entry (object 0x6020 (TC Inputs Ch.3), entry 0x07 (Error))	UINT32	RO	0x6020:07, 1
1A02:06	SubIndex 006	6. PDO Mapping entry (6 bits align)	UINT32	RO	0x0000:00, 6
1A02:07	SubIndex 007	7. PDO Mapping entry (object 0x6020 (TC Inputs Ch.3), entry 0x0E (Sync error))	UINT32	RO	0x6020:0E, 1
1A02:08	SubIndex 008	8. PDO Mapping entry (object 0x1802, entry 0x07)	UINT32	RO	0x1802:07, 1
1A02:09	SubIndex 009	9. PDO Mapping entry (object 0x1802, entry 0x09)	UINT32	RO	0x1802:09, 1
1A02:0A	SubIndex 010	10. PDO Mapping entry (object 0x6020 (TC Inputs Ch.3), entry 0x11 (Value))	UINT32	RO	0x6020:11, 16

**Index 1A03: TC TxPDO-Map TCInputs Ch.4**

Index (hex)	Name	Meaning	Data type	Flags	Default
1A03:0	TC TxPDO-Map TCInputs Ch.4	PDO Mapping TxPDO 4	UINT8	RO	0x0A (10 <sub>dec</sub> )
1A03:01	SubIndex 001	1. PDO Mapping entry (object 0x6030 (TC Inputs Ch.4), entry 0x01 (Underrange))	UINT32	RO	0x6030:01, 1
1A03:02	SubIndex 002	2. PDO Mapping entry (object 0x6030 (TC Inputs Ch.4), entry 0x02 (Overrange))	UINT32	RO	0x6030:02, 1
1A03:03	SubIndex 003	3. PDO Mapping entry (object 0x6030 (TC Inputs Ch.4), entry 0x03 (Limit 1))	UINT32	RO	0x6030:03, 2
1A03:04	SubIndex 004	4. PDO Mapping entry (object 0x6030 (TC Inputs Ch.4), entry 0x05 (Limit 2))	UINT32	RO	0x6030:05, 2
1A03:05	SubIndex 005	5. PDO Mapping entry (object 0x6030 (TC Inputs Ch.4), entry 0x07 (Error))	UINT32	RO	0x6030:07, 1
1A03:06	SubIndex 006	6. PDO Mapping entry (6 bits align)	UINT32	RO	0x0000:00, 6
1A03:07	SubIndex 007	7. PDO Mapping entry (object 0x6030 (TC Inputs Ch.4), entry 0x0E (Sync error))	UINT32	RO	0x6030:0E, 1
1A03:08	SubIndex 008	8. PDO Mapping entry (object 0x1803, entry 0x07)	UINT32	RO	0x1803:07, 1
1A03:09	SubIndex 009	9. PDO Mapping entry (object 0x1803, entry 0x09)	UINT32	RO	0x1803:09, 1
1A03:0A	SubIndex 010	10. PDO Mapping entry (object 0x6030 (TC Inputs Ch.4), entry 0x11 (Value))	UINT32	RO	0x6030:11, 16

**Index 1C00: Sync manager type**

Index (hex)	Name	Meaning	Data type	Flags	Default
1C00:0	Sync manager type	Using the sync managers	UINT8	RO	0x04 (4 <sub>dec</sub> )
1C00:01	SubIndex 001	Sync-Manager Type Channel 1: Mailbox Write	UINT8	RO	0x01 (1 <sub>dec</sub> )
1C00:02	SubIndex 002	Sync-Manager Type Channel 2: Mailbox Read	UINT8	RO	0x02 (2 <sub>dec</sub> )
1C00:03	SubIndex 003	Sync-Manager Type Channel 3: Process Data Write (Outputs)	UINT8	RO	0x03 (3 <sub>dec</sub> )
1C00:04	SubIndex 004	Sync-Manager Type Channel 4: Process Data Read (Inputs)	UINT8	RO	0x04 (4 <sub>dec</sub> )

**Index 1C12: RxPDO assign**

Index (hex)	Name	Meaning	Data type	Flags	Default
1C12:0	RxPDO assign	PDO Assign Outputs	UINT8	RW	0x00 (0 <sub>dec</sub> )
1C12:01	Subindex 001	1. allocated RxPDO (contains the index of the associated RxPDO mapping object)	UINT16	RW	0x0000 (0 <sub>dec</sub> )
1C12:02	Subindex 002	2. allocated RxPDO (contains the index of the associated RxPDO mapping object)	UINT16	RW	0x0000 (0 <sub>dec</sub> )
1C12:03	Subindex 003	3. allocated RxPDO (contains the index of the associated RxPDO mapping object)	UINT16	RW	0x0000 (0 <sub>dec</sub> )
1C12:04	Subindex 004	4. allocated RxPDO (contains the index of the associated RxPDO mapping object)	UINT16	RW	0x0000 (0 <sub>dec</sub> )

**Index 1C13: TxPDO assign**

Index (hex)	Name	Meaning	Data type	Flags	Default
1C13:0	TxPDO assign	PDO Assign Inputs	UINT8	RW	0x04 (4 <sub>dec</sub> )
1C13:01	Subindex 001	1. allocated TxPDO (contains the index of the associated TxPDO mapping object)	UINT16	RW	0x1A00 (6656 <sub>dec</sub> )
1C13:02	Subindex 002	2. allocated TxPDO (contains the index of the associated TxPDO mapping object)	UINT16	RW	0x1A01 (6657 <sub>dec</sub> )
1C13:03	Subindex 003	3. allocated TxPDO (contains the index of the associated TxPDO mapping object)	UINT16	RW	0x1A02 (6658 <sub>dec</sub> )
1C13:04	Subindex 004	4. allocated TxPDO (contains the index of the associated TxPDO mapping object)	UINT16	RW	0x1A03 (6659 <sub>dec</sub> )

## Index 1C32: SM output parameter

Index (hex)	Name	Meaning	Data type	Flags	Default
1C32:0	SM output parameter	Synchronization parameters for the outputs	UINT8	RO	0x20 (32 <sub>dec</sub> )
1C32:01	Sync mode	Current synchronization mode: <ul style="list-style-type: none"> <li>0: Free Run</li> <li>1: Synchronous with SM 2 event</li> <li>2: DC-Mode - Synchronous with SYNC0 Event</li> <li>3: DC-Mode - Synchronous with SYNC1 event</li> </ul>	UINT16	RW	0x0000 (0 <sub>dec</sub> )
1C32:02	Cycle time	Cycle time (in ns): <ul style="list-style-type: none"> <li>Free Run: Cycle time of the local timer</li> <li>Synchronous with SM 2 event: Master cycle time</li> <li>DC mode: SYNC0/SYNC1 Cycle Time</li> </ul>	UINT32	RW	0x000F4240 (1000000 <sub>dec</sub> )
1C32:03	Shift time	Time between SYNC0 event and output of the outputs (in ns, DC mode only)	UINT32	RO	0x00000000 (0 <sub>dec</sub> )
1C32:04	Sync modes supported	Supported synchronization modes: <ul style="list-style-type: none"> <li>Bit 0 = 1: free run is supported</li> <li>Bit 1 = 1: Synchronous with SM 2 event is supported</li> <li>Bit 2-3 = 01: DC mode is supported</li> <li>Bit 4-5 = 10: Output shift with SYNC1 event (only DC mode)</li> <li>Bit 14 = 1: dynamic times (measurement through writing of 0x1C32:08 [▶ 102])</li> </ul>	UINT16	RO	0xC007 (49159 <sub>dec</sub> )
1C32:05	Minimum cycle time	Minimum cycle time (in ns)	UINT32	RO	0x00002710 (10000 <sub>dec</sub> )
1C32:06	Calc and copy time	Minimum time between SYNC0 and SYNC1 event (in ns, DC mode only)	UINT32	RO	0x00000000 (0 <sub>dec</sub> )
1C32:07	Minimum delay time		UINT32	RO	0x00000000 (0 <sub>dec</sub> )
1C32:08	Command	<ul style="list-style-type: none"> <li>0: Measurement of the local cycle time is stopped</li> <li>1: Measurement of the local cycle time is started</li> </ul> <p>The entries 0x1C32:03 [▶ 102], 0x1C32:05 [▶ 102], 0x1C32:06 [▶ 102], 0x1C32:09 [▶ 102], 0x1C33:03 [▶ 103], 0x1C33:06 [▶ 102], 0x1C33:09 [▶ 103] are updated with the maximum measured values. For a subsequent measurement the measured values are reset</p>	UINT16	RW	0x0000 (0 <sub>dec</sub> )
1C32:09	Maximum Delay time	Time between SYNC1 event and output of the outputs (in ns, DC mode only)	UINT32	RO	0x00000000 (0 <sub>dec</sub> )
1C32:0B	SM event missed counter	Number of missed SM events in OPERATIONAL (DC mode only)	UINT16	RO	0x0000 (0 <sub>dec</sub> )
1C32:0C	Cycle exceeded counter	Number of occasions the cycle time was exceeded in OPERATIONAL (cycle was not completed in time or the next cycle began too early)	UINT16	RO	0x0000 (0 <sub>dec</sub> )
1C32:0D	Shift too short counter	Number of occasions that the interval between SYNC0 and SYNC1 event was too short (DC mode only)	UINT16	RO	0x0000 (0 <sub>dec</sub> )
1C32:20	Sync error	The synchronization was not correct in the last cycle (outputs were output too late; DC mode only)	BOOLEAN	RO	0x00 (0 <sub>dec</sub> )

**Index 1C33: SM input parameter**

Index (hex)	Name	Meaning	Data type	Flags	Default
1C33:0	SM input parameter	Synchronization parameters for the inputs	UINT8	RO	0x20 (32 <sub>dec</sub> )
1C33:01	Sync mode	Current synchronization mode: <ul style="list-style-type: none"> <li>• 0: Free Run</li> <li>• 1: Synchronous with SM 3 Event (no outputs available)</li> <li>• 2: DC - Synchronous with SYNC0 Event</li> <li>• 3: DC - Synchron with SYNC1 Event</li> <li>• 34: Synchron with SM 2 Event (outputs available)</li> </ul>	UINT16	RW	0x0000 (0 <sub>dec</sub> )
1C33:02	Cycle time	as <a href="#">0x1C32:02</a> [ <a href="#">102</a> ]	UINT32	RW	0x000F4240 (1000000 <sub>dec</sub> )
1C33:03	Shift time	Time between SYNC0 event and reading of the inputs (in ns, only DC mode)	UINT32	RO	0x00000000 (0 <sub>dec</sub> )
1C33:04	Sync modes supported	Supported synchronization modes: <ul style="list-style-type: none"> <li>• Bit 0: free run is supported</li> <li>• Bit 1: Synchron with SM 2 Event is supported (outputs available)</li> <li>• Bit 1: Synchron with SM 3 Event is supported (no outputs available)</li> <li>• Bit 2-3 = 01: DC mode is supported</li> <li>• Bit 4-5 = 01: input shift through local event (outputs available)</li> <li>• Bit 4-5 = 10: input shift with SYNC1 event (no outputs available)</li> <li>• Bit 14 = 1: dynamic times (measurement through writing of <a href="#">0x1C32:08</a> [<a href="#">102</a>] or <a href="#">0x1C33:08</a> [<a href="#">103</a>])</li> </ul>	UINT16	RO	0xC007 (49159 <sub>dec</sub> )
1C33:05	Minimum cycle time	as <a href="#">0x1C32:05</a> [ <a href="#">102</a> ]	UINT32	RO	0x00002710 (10000 <sub>dec</sub> )
1C33:06	Calc and copy time	Time between reading of the inputs and availability of the inputs for the master (in ns, only DC mode)	UINT32	RO	0x00000000 (0 <sub>dec</sub> )
1C33:07	Minimum delay time		UINT32	RO	0x00000000 (0 <sub>dec</sub> )
1C33:08	Command	as <a href="#">0x1C32:08</a> [ <a href="#">102</a> ]	UINT16	RW	0x0000 (0 <sub>dec</sub> )
1C33:09	Maximum Delay time	Time between SYNC1 event and reading of the inputs (in ns, only DC mode)	UINT32	RO	0x00000000 (0 <sub>dec</sub> )
1C33:0B	SM event missed counter	as <a href="#">0x1C32:11</a> [ <a href="#">102</a> ]	UINT16	RO	0x0000 (0 <sub>dec</sub> )
1C33:0C	Cycle exceeded counter	as <a href="#">0x1C32:12</a> [ <a href="#">102</a> ]	UINT16	RO	0x0000 (0 <sub>dec</sub> )
1C33:0D	Shift too short counter	as <a href="#">0x1C32:13</a> [ <a href="#">102</a> ]	UINT16	RO	0x0000 (0 <sub>dec</sub> )
1C33:20	Sync error	as <a href="#">0x1C32:32</a> [ <a href="#">102</a> ]	BOOLEAN	RO	0x00 (0 <sub>dec</sub> )



## 6.7.4 Profile-specific objects (0x6000-0xFFFF)

The profile-specific objects have the same meaning for all EtherCAT slaves that support the profile 5001.

### Index 6000: TC Inputs Ch.1

Index (hex)	Name	Meaning	Data type	Flags	Default
6000:0	TC Inputs Ch.1	Maximum subindex	UINT8	RO	0x11 (17 <sub>dec</sub> )
6000:01	Underrange	Is set if the value falls below the operating range of the sensor or the process record contains the lowest possible value.	BOOLEAN	RO	0x00 (0 <sub>dec</sub> )
6000:02	Overrange	Is set if the value exceeds the operating range of the sensor or the process record contains the highest possible value.	BOOLEAN	RO	0x00 (0 <sub>dec</sub> )
6000:03	Limit 1	Only when limit check is active	BIT2	RO	0x00 (0 <sub>dec</sub> )
		1 Value below set limit			
		2 Set limit exceeded			
		3 Set limit reached			
6000:05	Limit 2	Only when limit check is active	BIT2	RO	0x00 (0 <sub>dec</sub> )
		1 Value below set limit			
		2 Set limit exceeded			
		3 Set limit reached			
6000:07	Error	The error bit is set if the process data is invalid (cable break, overrange, underrange)	BOOLEAN	RO	0x00 (0 <sub>dec</sub> )
6000:0E	Sync error	Only in DC: bit is set if the slave is not able to operate synchronous with master, because it cannot keep up with the cycle time.	BOOLEAN	RO	0x00 (0 <sub>dec</sub> )
6000:0F	TxPDO State	Validity of the data of the associated TxPDO	BOOLEAN	RO	0x00 (0 <sub>dec</sub> )
		0 valid			
		1 invalid			
6000:10	TxPDO Toggle	TxPDO toggle is toggled by the slave when the data of the associated TxPDO is updated.	BOOLEAN	RO	0x00 (0 <sub>dec</sub> )
6000:11	Value	Analog input value (resolution in 1/10 °C)	INT16	RO	0x0000 (0 <sub>dec</sub> )

### Index 6010: TC Inputs Ch.2

Index (hex)	Name	Meaning	Data type	Flags	Default
6010:0	TC Inputs Ch.2	Maximum subindex	UINT8	RO	0x11 (17 <sub>dec</sub> )
6010:01	Underrange	Is set if the value falls below the operating range of the sensor or the process record contains the lowest possible value.	BOOLEAN	RO	0x00 (0 <sub>dec</sub> )
6010:02	Overrange	Is set if the value exceeds the operating range of the sensor or the process record contains the highest possible value.	BOOLEAN	RO	0x00 (0 <sub>dec</sub> )
6010:03	Limit 1	Only when limit check is active	BIT2	RO	0x00 (0 <sub>dec</sub> )
		1 Value below set limit			
		2 Set limit exceeded			
		3 Set limit reached			
6010:05	Limit 2	Only when limit check is active	BIT2	RO	0x00 (0 <sub>dec</sub> )
		1 Value below set limit			
		2 Set limit exceeded			
		3 Set limit reached			
6010:07	Error	The error bit is set if the process data is invalid (cable break, overrange, underrange)	BOOLEAN	RO	0x00 (0 <sub>dec</sub> )
6010:0E	Sync error	Only in DC: bit is set if the slave is not able to operate synchronous with master, because it cannot keep up with the cycle time.	BOOLEAN	RO	0x00 (0 <sub>dec</sub> )
6010:0F	TxPDO State	Validity of the data of the associated TxPDO	BOOLEAN	RO	0x00 (0 <sub>dec</sub> )
		0 valid			
		1 invalid			
6010:10	TxPDO Toggle	TxPDO toggle is toggled by the slave when the data of the associated TxPDO is updated.	BOOLEAN	RO	0x00 (0 <sub>dec</sub> )
6010:11	Value	Analog input value (resolution in 1/10 °C)	INT16	RO	0x0000 (0 <sub>dec</sub> )



**Index 6020: TC Inputs Ch.3**

Index (hex)	Name	Meaning	Data type	Flags	Default	
6020:0	TC Inputs Ch.3	Maximum subindex	UINT8	RO	0x11 (17 <sub>dec</sub> )	
6020:01	Underrange	Is set if the value falls below the operating range of the sensor or the process record contains the lowest possible value.	BOOLEAN	RO	0x00 (0 <sub>dec</sub> )	
6020:02	Overrange	Is set if the value exceeds the operating range of the sensor or the process record contains the highest possible value.	BOOLEAN	RO	0x00 (0 <sub>dec</sub> )	
6020:03	Limit 1	Only when limit check is active	BIT2	RO	0x00 (0 <sub>dec</sub> )	
		1				Value below set limit
		2				Set limit exceeded
		3				Set limit reached
6020:05	Limit 2	Only when limit check is active	BIT2	RO	0x00 (0 <sub>dec</sub> )	
		1				Value below set limit
		2				Set limit exceeded
		3				Set limit reached
6020:07	Error	The error bit is set if the process data is invalid (cable break, overrange, underrange)	BOOLEAN	RO	0x00 (0 <sub>dec</sub> )	
6020:0E	Sync error	Only in DC: bit is set if the slave is not able to operate synchronous with master, because it cannot keep up with the cycle time.	BOOLEAN	RO	0x00 (0 <sub>dec</sub> )	
6020:0F	TxPDO State	Validity of the data of the associated TxPDO	BOOLEAN	RO	0x00 (0 <sub>dec</sub> )	
		0				valid
		1				invalid
6020:10	TxPDO Toggle	TxPDO toggle is toggled by the slave when the data of the associated TxPDO is updated.	BOOLEAN	RO	0x00 (0 <sub>dec</sub> )	
6020:11	Value	Analog input value (resolution in 1/10°C)	INT16	RO	0x0000 (0 <sub>dec</sub> )	

**Index 6030: TC Inputs Ch.4**

Index (hex)	Name	Meaning	Data type	Flags	Default	
6030:0	TC Inputs Ch.4	Maximum subindex	UINT8	RO	0x11 (17 <sub>dec</sub> )	
6030:01	Underrange	Is set if the value falls below the operating range of the sensor or the process record contains the lowest possible value.	BOOLEAN	RO	0x00 (0 <sub>dec</sub> )	
6030:02	Overrange	Is set if the value exceeds the operating range of the sensor or the process record contains the highest possible value.	BOOLEAN	RO	0x00 (0 <sub>dec</sub> )	
6030:03	Limit 1	Only when limit check is active	BIT2	RO	0x00 (0 <sub>dec</sub> )	
		1				Value below set limit
		2				Set limit reached
		3				Set limit exceeded
6030:05	Limit 2	Only when limit check is active	BIT2	RO	0x00 (0 <sub>dec</sub> )	
		1				Value below set limit
		2				Set limit reached
		3				Set limit exceeded
6030:07	Error	The error bit is set if the process data is invalid (cable break, overrange, underrange)	BOOLEAN	RO	0x00 (0 <sub>dec</sub> )	
6030:0E	Sync error	Only in DC: bit is set if the slave is not able to operate synchronous with master, because it cannot keep up with the cycle time.	BOOLEAN	RO	0x00 (0 <sub>dec</sub> )	
6030:0F	TxPDO State	Validity of the data of the associated TxPDO	BOOLEAN	RO	0x00 (0 <sub>dec</sub> )	
		0				valid
		1				invalid
6030:10	TxPDO Toggle	TxPDO toggle is toggled by the slave when the data of the associated TxPDO is updated.	BOOLEAN	RO	0x00 (0 <sub>dec</sub> )	
6030:11	Value	Analog input value (resolution in 1/10°C)	INT16	RO	0x0000 (0 <sub>dec</sub> )	

**Index 7000: TC Outputs Ch.1**

Index (hex)	Name	Meaning	Data type	Flags	Default
7000:0	TC Outputs Ch.1	Maximum subindex	UINT8	RO	0x11 (17 <sub>dec</sub> )
7000:11	CJCompensation	Temperature of the cold junction (resolution in 1/10°C) (index 0x8000:0C [▶ 93], comparison via the process data)	INT16	RO	0x0000 (0 <sub>dec</sub> )

**Index 7010: TC Outputs Ch.2**

Index (hex)	Name	Meaning	Data type	Flags	Default
7010:0	TC Outputs Ch.2	Maximum subindex	UINT8	RO	0x11 (17 <sub>dec</sub> )
7010:11	CJCompensation	Temperature of the cold junction (resolution in 1/10°C) (index 0x8000:0C [▶ 94], comparison via the process data)	INT16	RO	0x0000 (0 <sub>dec</sub> )

**Index 7020: TC Outputs Ch.3**

Index (hex)	Name	Meaning	Data type	Flags	Default
7020:0	TC Outputs Ch.3	Maximum subindex	UINT8	RO	0x11 (17 <sub>dec</sub> )
7020:11	CJCompensation	Temperature of the cold junction (resolution in 1/10°C) (index 0x8020:0C [▶ 95], comparison via the process data)	INT16	RO	0x0000 (0 <sub>dec</sub> )

**Index 7030: TC Outputs Ch.4**

Index (hex)	Name	Meaning	Data type	Flags	Default
7030:0	TC Outputs Ch.4	Maximum subindex	UINT8	RO	0x11 (17 <sub>dec</sub> )
7030:11	CJCompensation	Temperature of the cold junction (resolution in 1/10°C) (index 0x8030:0C [▶ 97], comparison via the process data)	INT16	RO	0x0000 (0 <sub>dec</sub> )

**Index 800E: TC Internal data Ch.1**

Index (hex)	Name	Meaning	Data type	Flags	Default
800E:0	TC Internal data Ch.1	Maximum subindex	UINT8	RO	0x05 (5 <sub>dec</sub> )
800E:01	ADC raw value TC	Raw value of the analog/digital converter for the thermocouple	INT32	RO	0x00000000 (0 <sub>dec</sub> )
800E:02	ADC raw value PT1000	Raw value of the analog/digital converter for the Pt1000	INT32	RO	0x00000000 (0 <sub>dec</sub> )
800E:03	CJ temperature	Cold junction temperature (resolution 1/100 °C)	INT16	RO	0x0000 (0 <sub>dec</sub> )
800E:04	CJ voltage	Cold junction voltage (resolution 1 µV)	INT16	RO	0x0000 (0 <sub>dec</sub> )
800E:05	CJ resistor	Cold junction resistance for Pt1000 temperature sensor (resolution 1/10 ohm)	UINT16	RO	0x0000 (0 <sub>dec</sub> )

**Index 800F: TC Vendor data Ch.1**

Index (hex)	Name	Meaning	Data type	Flags	Default
800F:0	TC Vendor data Ch.1	Maximum subindex	UINT8	RO	0x04 (4 <sub>dec</sub> )
800F:01	Calibration offset TC	Manufacturer calibration for thermocouple: Offset	INT16	RW	0x0000 (0 <sub>dec</sub> )
800F:02	Calibration gain TC	Manufacturer calibration for thermocouple: Gain	UINT16	RW	0x4000 (16384 <sub>dec</sub> )
800F:03	Calibration offset CJ	Manufacturer calibration for cold junction (Pt1000): Offset	INT16	RW	0x0000 (0 <sub>dec</sub> )
800F:04	Calibration gain CJ	Manufacturer calibration for cold junction (Pt1000): Gain	UINT16	RW	0x4000 (16384 <sub>dec</sub> )

**Index 801E: TC Internal data Ch.2**

Index (hex)	Name	Meaning	Data type	Flags	Default
801E:0	TC Internal data Ch.2	Maximum subindex	UINT8	RO	0x05 (5 <sub>dec</sub> )
801E:01	ADC raw value TC	Raw value of the analog/digital converter for the thermocouple	INT32	RO	0x00000000 (0 <sub>dec</sub> )
801E:02	ADC raw value PT1000	Raw value of the analog/digital converter for the Pt1000	INT32	RO	0x00000000 (0 <sub>dec</sub> )
801E:03	CJ temperature	Cold junction temperature (resolution 1/100 °C)	INT16	RO	0x0000 (0 <sub>dec</sub> )
801E:04	CJ voltage	Cold junction voltage (resolution 1 µV)	INT16	RO	0x0000 (0 <sub>dec</sub> )
801E:05	CJ resistor	Cold junction resistance for Pt1000 temperature sensor (resolution 1/10 ohm)	UINT16	RO	0x0000 (0 <sub>dec</sub> )

**Index 801F: TC Vendor data Ch.2**

Index (hex)	Name	Meaning	Data type	Flags	Default
801F:0	TC Vendor data Ch.2	Maximum subindex	UINT8	RO	0x04 (4 <sub>dec</sub> )
801F:01	Calibration offset TC	Manufacturer calibration for thermocouple: Offset	INT16	RW	0x0000 (0 <sub>dec</sub> )
801F:02	Calibration gain TC	Manufacturer calibration for thermocouple: Gain	UINT16	RW	0x4000 (16384 <sub>dec</sub> )
801F:03	Calibration offset CJ	Manufacturer calibration for cold junction (Pt1000): Offset	INT16	RW	0x0000 (0 <sub>dec</sub> )
801F:04	Calibration gain CJ	Manufacturer calibration for cold junction (Pt1000): Gain	UINT16	RW	0x4000 (16384 <sub>dec</sub> )

**Index 802E: TC Internal data Ch.3**

Index (hex)	Name	Meaning	Data type	Flags	Default
802E:0	TC Internal data Ch.3	Maximum subindex	UINT8	RO	0x05 (5 <sub>dec</sub> )
802E:01	ADC raw value TC	Raw value of the analog/digital converter for the thermocouple	INT32	RO	0x00000000 (0 <sub>dec</sub> )
802E:02	ADC raw value PT1000	Raw value of the analog/digital converter for the Pt1000	INT32	RO	0x00000000 (0 <sub>dec</sub> )
802E:03	CJ temperature	Cold junction temperature (resolution 1/100 °C)	INT16	RO	0x0000 (0 <sub>dec</sub> )
802E:04	CJ voltage	Cold junction voltage (resolution 1 µV)	INT16	RO	0x0000 (0 <sub>dec</sub> )
802E:05	CJ resistor	Cold junction resistance for Pt1000 temperature sensor (resolution 1/10 ohm)	UINT16	RO	0x0000 (0 <sub>dec</sub> )

**Index 802F: TC Vendor data Ch.3**

Index (hex)	Name	Meaning	Data type	Flags	Default
802F:0	TC Vendor data Ch.3	Maximum subindex	UINT8	RO	0x04 (4 <sub>dec</sub> )
802F:01	Calibration offset TC	Manufacturer calibration for thermocouple: Offset	INT16	RW	0x0000 (0 <sub>dec</sub> )
802F:02	Calibration gain TC	Manufacturer calibration for thermocouple: Gain	UINT16	RW	0x4000 (16384 <sub>dec</sub> )
802F:03	Calibration offset CJ	Manufacturer calibration for cold junction (Pt1000): Offset	INT16	RW	0x0000 (0 <sub>dec</sub> )
802F:04	Calibration gain CJ	Manufacturer calibration for cold junction (Pt1000): Gain	UINT16	RW	0x4000 (16384 <sub>dec</sub> )

**Index 803E: TC Internal data Ch.4**

Index (hex)	Name	Meaning	Data type	Flags	Default
803E:0	TC Internal data Ch.4	Maximum subindex	UINT8	RO	0x05 (5 <sub>dec</sub> )
803E:01	ADC raw value TC	Raw value of the analog/digital converter for the thermocouple	INT32	RO	0x00000000 (0 <sub>dec</sub> )
803E:02	ADC raw value PT1000	Raw value of the analog/digital converter for the Pt1000	INT32	RO	0x00000000 (0 <sub>dec</sub> )
803E:03	CJ temperature	Cold junction temperature (resolution 1/100 °C)	INT16	RO	0x0000 (0 <sub>dec</sub> )
803E:04	CJ voltage	Cold junction voltage (resolution 1 µV)	INT16	RO	0x0000 (0 <sub>dec</sub> )
803E:05	CJ resistor	Cold junction resistance for Pt1000 temperature sensor (resolution 1/10 ohm)	UINT16	RO	0x0000 (0 <sub>dec</sub> )

**Index 803F: TC Vendor data Ch.4**

Index (hex)	Name	Meaning	Data type	Flags	Default
803F:0	TC Vendor data Ch.4	Maximum subindex	UINT8	RO	0x04 (4 <sub>dec</sub> )
803F:01	Calibration offset TC	Manufacturer calibration for thermocouple: Offset	INT16	RW	0x0000 (0 <sub>dec</sub> )
803F:02	Calibration gain TC	Manufacturer calibration for thermocouple: Gain	UINT16	RW	0x4000 (16384 <sub>dec</sub> )
803F:03	Calibration offset CJ	Manufacturer calibration for cold junction (Pt1000): Offset	INT16	RW	0x0000 (0 <sub>dec</sub> )
803F:04	Calibration gain CJ	Manufacturer calibration for cold junction (Pt1000): Gain	UINT16	RW	0x4000 (16384 <sub>dec</sub> )

**Index F000: Modular device profile**

Index (hex)	Name	Meaning	Data type	Flags	Default
F000:0	Modular device profile	Maximum subindex	UINT8	RO	0x02 (2 <sub>dec</sub> )
F000:01	Module index distance	Index spacing for the objects of the individual channels	UINT16	RO	0x0010 (16 <sub>dec</sub> )
F000:02	Maximum number of modules	Number of channels	UINT16	RO	0x0004 (4 <sub>dec</sub> )

**Index F008: Code word**

Index (hex)	Name	Meaning	Data type	Flags	Default
F008:0	Code word	reserved	UINT32	RW	0x00000000 (0 <sub>dec</sub> )

**Index F010: Module list**

Index (hex)	Name	Meaning	Data type	Flags	Default
F010:0	Module list	Maximum subindex	UINT8	RW	0x04 (4 <sub>dec</sub> )
F010:01	SubIndex 001		UINT32	RW	0x0000014A (330 <sub>dec</sub> )
F010:02	SubIndex 002		UINT32	RW	0x0000014A (330 <sub>dec</sub> )
F010:03	SubIndex 003		UINT32	RW	0x0000014A (330 <sub>dec</sub> )
F010:04	SubIndex 004		UINT32	RW	0x0000014A (330 <sub>dec</sub> )

**Index F080: Channel Enable**

Index (hex)	Name	Meaning	Data type	Flags	Default	
F080:0	Channel Enable	Maximum subindex	UINT8	RO	0x04 (4 <sub>dec</sub> )	
F080:01	SubIndex 001	0	Channel 1 disabled	(from hardware version 01 deactivated channels are not measured, and the green LED R for these channels goes out)	RW	0x01 (1 <sub>dec</sub> )
		1	Channel 1 enabled			
F080:02	SubIndex 002	0	Channel 2 disabled		RW	0x01 (1 <sub>dec</sub> )
		1	Channel 2 enabled			
F080:03	SubIndex 003	0	Channel 3 disabled		RW	0x01 (1 <sub>dec</sub> )
		1	Channel 3 enabled			
F080:04	SubIndex 004	0	Channel 4 disabled		RW	0x01 (1 <sub>dec</sub> )
		1	Channel 5 enabled			

## 6.8 Restoring the delivery state

To restore the delivery state for backup objects in ELxxxx terminals / EPxxxx- and EPPxxxx box modules, the CoE object *Restore default parameters, SubIndex 001* can be selected in the TwinCAT System Manager (Config mode).

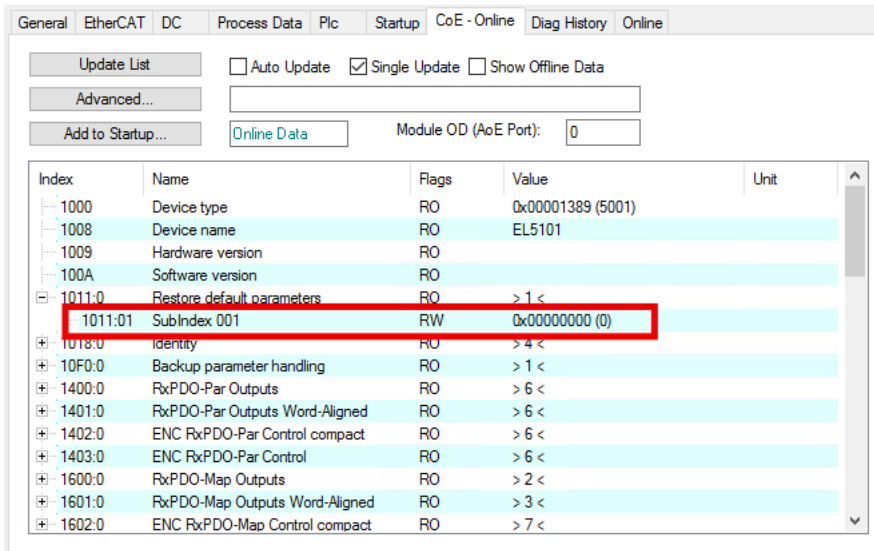

Fig. 20: Selecting the Restore default parameters PDO

Double-click on *SubIndex 001* to enter the Set Value dialog. Enter the value **1684107116** in field *Dec* or the value **0x64616F6C** in field *Hex* and confirm with OK.

All backup objects are reset to the delivery state.

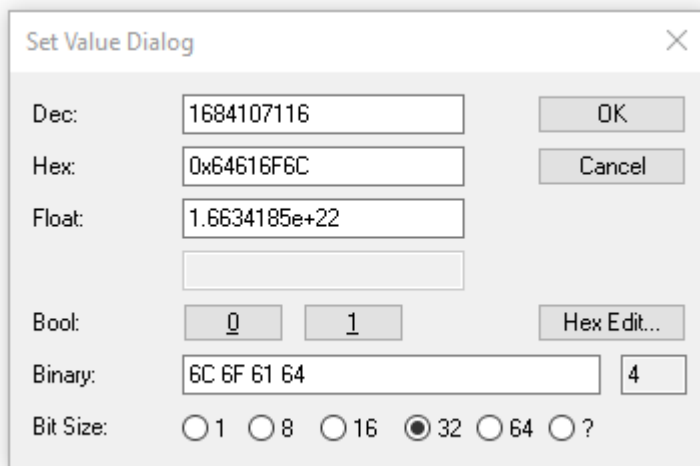

Fig. 21: Entering a restore value in the Set Value dialog

### **i** Alternative restore value

In some older terminals / boxes the backup objects can be switched with an alternative restore value:

Decimal value: 1819238756

Hexadecimal value: 0x6C6F6164

An incorrect entry for the restore value has no effect.

## 6.9 Decommissioning

**⚠ WARNING****Risk of electric shock!**

Bring the bus system into a safe, de-energized state before starting disassembly of the devices!

## 7 Appendix

### 7.1 General operating conditions

#### Protection rating according to IP code

The degrees of protection are defined and divided into different classes in the IEC 60529 standard (EN 60529). Degrees of protection are designated by the letters "IP" and two numerals: **IPxy**

- Numeral x: Dust protection and contact protection
- Numeral y: Protection against water

x	Meaning
0	Not protected
1	Protected against access to dangerous parts with the back of the hand. Protected against solid foreign objects of 50 mm Ø
2	Protected against access to dangerous parts with a finger. Protected against solid foreign objects of 12.5 mm Ø
3	Protected against access to dangerous parts with a tool. Protected against solid foreign objects of 2.5 mm Ø
4	Protected against access to dangerous parts with a wire. Protected against solid foreign objects of 1 mm Ø
5	Protection against access to dangerous parts with a wire. Dust-protected. Ingress of dust is not prevented completely, although the quantity of dust able to penetrate is limited to such an extent that the proper function of the device and safety are not impaired
6	Protection against access to dangerous parts with a wire. Dust-tight. No ingress of dust

y	Meaning
0	Not protected
1	Protection against vertically falling water drops
2	Protection against vertically falling water drops when enclosure tilted up to 15°
3	Protection against spraying water. Water sprayed at an angle of up to 60° on either side of the vertical shall have no harmful effects
4	Protection against splashing water. Water splashed against the enclosure from any direction shall have no harmful effects
5	Protection against water jets.
6	Protection against powerful water jets.
7	Protected against the effects of temporary immersion in water. Ingress of water in quantities causing harmful effects shall not be possible when the enclosure is immersed in water at a depth of 1 m for 30 minutes

#### Chemical resistance

The resistance refers to the housing of the IP67 modules and the metal parts used. In the table below you will find some typical resistances.

Type	Resistance
Water vapor	unstable at temperatures > 100 °C
Sodium hydroxide solution (ph value > 12)	stable at room temperature unstable > 40 °C
Acetic acid	unstable
Argon (technically pure)	stable

#### Key

- resistant: Lifetime several months
- non inherently resistant: Lifetime several weeks
- not resistant: Lifetime several hours resp. early decomposition

## 7.2 Accessories

### Mounting

Ordering information	Description	Link
ZS5300-0011	Mounting rail	<a href="#">Website</a>

### Cables and connectors

A complete overview of pre-assembled cables for fieldbus components can be found [here](#).

Ordering information	Description	Link
ZK1090-3xxx-xxxx	EtherCAT cable M8, green	<a href="#">Website</a>
ZK1093-3xxx-xxxx	EtherCAT cable M8, yellow	<a href="#">Website</a>
ZK2000-7xxx-0xxx	Sensor cable M12, 4-pin + shield	<a href="#">Website</a>
ZK2020-3xxx-xxxx	Power cable M8, 4-pin	<a href="#">Website</a>
ZS2000-3712	Sensor plug M12 with thermocouple compensation	<a href="#">Website</a>

### Labeling material, protective caps

Ordering information	Description
ZS5000-0010	Protective cap for M8 sockets, IP67 (50 pieces)
ZS5000-0020	Protective cap for M12 sockets, IP67 (50 pcs.)
ZS5100-0000	Inscription labels, unprinted, 4 strips of 10
ZS5000-xxxx	Printed inscription labels on enquiry

### Tools

Ordering information	Description
ZB8801-0000	Torque wrench for plugs, 0.4...1.0 Nm
ZB8801-0001	Torque cable key for M8 / wrench size 9 for ZB8801-0000
ZB8801-0002	Torque cable key for M12 / wrench size 13 for ZB8801-0000
ZB8801-0003	Torque cable key for M12 field assembly / wrench size 18 for ZB8801-0000



#### Further accessories

Further accessories can be found in the price list for fieldbus components from Beckhoff and online at <https://www.beckhoff.com>.



## 7.3 Version identification of EtherCAT devices

### 7.3.1 General notes on marking

#### Designation

A Beckhoff EtherCAT device has a 14-digit designation, made up of

- family key
- type
- version
- revision

Example	Family	Type	Version	Revision
EL3314-0000-0016	EL terminal 12 mm, non-pluggable connection level	3314 4-channel thermocouple terminal	0000 basic type	0016
ES3602-0010-0017	ES terminal 12 mm, pluggable connection level	3602 2-channel voltage measurement	0010 high-precision version	0017
CU2008-0000-0000	CU device	2008 8-port fast ethernet switch	0000 basic type	0000

#### Notes

- The elements mentioned above result in the **technical designation**. EL3314-0000-0016 is used in the example below.
- EL3314-0000 is the order identifier, in the case of “-0000” usually abbreviated to EL3314. “-0016” is the EtherCAT revision.
- The **order identifier** is made up of
  - family key (EL, EP, CU, ES, KL, CX, etc.)
  - type (3314)
  - version (-0000)
- The **revision** -0016 shows the technical progress, such as the extension of features with regard to the EtherCAT communication, and is managed by Beckhoff.  
 In principle, a device with a higher revision can replace a device with a lower revision, unless specified otherwise, e.g. in the documentation.  
 Associated and synonymous with each revision there is usually a description (ESI, EtherCAT Slave Information) in the form of an XML file, which is available for download from the Beckhoff web site.  
 From 2014/01 the revision is shown on the outside of the IP20 terminals, see Fig. “EL5021 EL terminal, standard IP20 IO device with batch number and revision ID (since 2014/01)”.
- The type, version and revision are read as decimal numbers, even if they are technically saved in hexadecimal.

### 7.3.2 Version identification of IP67 modules

The serial number/ data code for Beckhoff IO devices is usually the 8-digit number printed on the device or on a sticker. The serial number indicates the configuration in delivery state and therefore refers to a whole production batch, without distinguishing the individual modules of a batch.

Structure of the serial number: **KK YY FF HH**

KK - week of production (CW, calendar week)

YY - year of production

FF - firmware version

HH - hardware version

Example with serial number 12 06 3A 02:

12 - production week 12

06 - production year 2006

3A - firmware version 3A

02 - hardware version 02

Exceptions can occur in the **IP67 area**, where the following syntax can be used (see respective device documentation):

Syntax: D ww yy x y z u

D - prefix designation

ww - calendar week

yy - year

x - firmware version of the bus PCB

y - hardware version of the bus PCB

z - firmware version of the I/O PCB

u - hardware version of the I/O PCB

Example: D.22081501 calendar week 22 of the year 2008 firmware version of bus PCB: 1 hardware version of bus PCB: 5 firmware version of I/O PCB: 0 (no firmware necessary for this PCB) hardware version of I/O PCB: 1

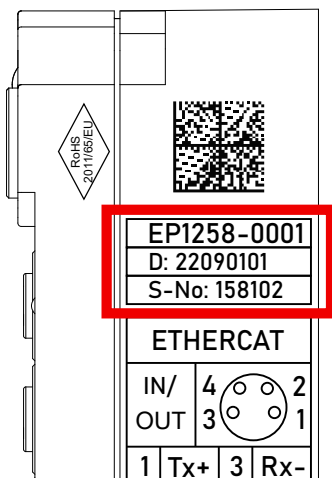

Fig. 22: EP1258-00001 IP67 EtherCAT Box with batch number/DateCode 22090101 and unique serial number 158102

### 7.3.3 Beckhoff Identification Code (BIC)

The Beckhoff Identification Code (BIC) is increasingly being applied to Beckhoff products to uniquely identify the product. The BIC is represented as a Data Matrix Code (DMC, code scheme ECC200), the content is based on the ANSI standard MH10.8.2-2016.

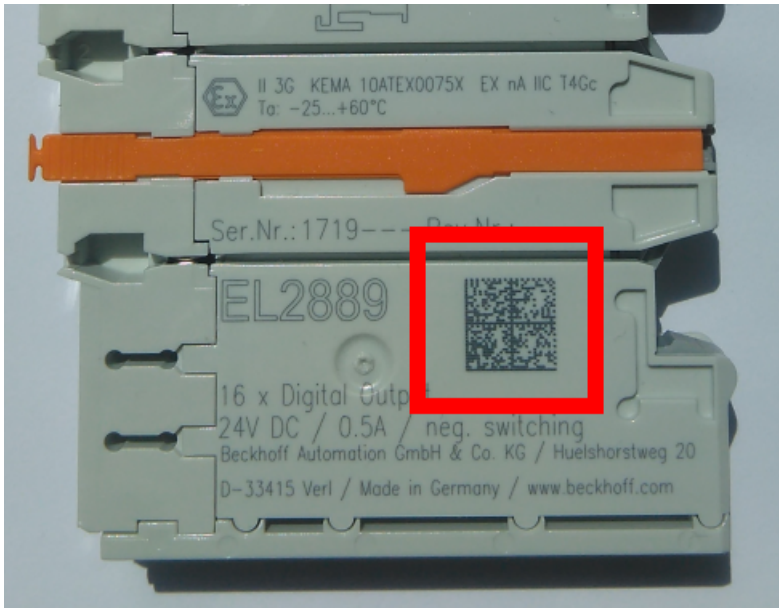

Fig. 23: BIC as data matrix code (DMC, code scheme ECC200)

The BIC will be introduced step by step across all product groups.

Depending on the product, it can be found in the following places:

- on the packaging unit
- directly on the product (if space suffices)
- on the packaging unit and the product

The BIC is machine-readable and contains information that can also be used by the customer for handling and product management.

Each piece of information can be uniquely identified using the so-called data identifier (ANSI MH10.8.2-2016). The data identifier is followed by a character string. Both together have a maximum length according to the table below. If the information is shorter, spaces are added to it.

Following information is possible, positions 1 to 4 are always present, the other according to need of production:

Position	Type of information	Explanation	Data identifier	Number of digits incl. data identifier	Example
1	Beckhoff order number	<b>Beckhoff order number</b>	1P	8	<b>1P</b> 072222
2	Beckhoff Traceability Number (BTN)	<b>Unique serial number, see note below</b>	SBTN	12	<b>S</b> BTNk4p562d7
3	Article description	<b>Beckhoff article description, e.g. EL1008</b>	1K	32	<b>1K</b> EL1809
4	Quantity	<b>Quantity in packaging unit, e.g. 1, 10, etc.</b>	Q	6	<b>Q</b> 1
5	Batch number	Optional: Year and week of production	2P	14	<b>2P</b> 401503180016
6	ID/serial number	Optional: Present-day serial number system, e.g. with safety products	51S	12	<b>51S</b> 678294
7	Variant number	Optional: Product variant number on the basis of standard products	30P	32	<b>30P</b> F971, 2*K183
...					

Further types of information and data identifiers are used by Beckhoff and serve internal processes.

### Structure of the BIC

Example of composite information from positions 1 to 4 and with the above given example value on position 6. The data identifiers are highlighted in bold font:

**1P**072222**S**BTNk4p562d7**1K**EL1809 **Q**1 **51S**678294

Accordingly as DMC:



Fig. 24: Example DMC **1P**072222**S**BTNk4p562d7**1K**EL1809 **Q**1 **51S**678294

### BTN

An important component of the BIC is the Beckhoff Traceability Number (BTN, position 2). The BTN is a unique serial number consisting of eight characters that will replace all other serial number systems at Beckhoff in the long term (e.g. batch designations on IO components, previous serial number range for safety products, etc.). The BTN will also be introduced step by step, so it may happen that the BTN is not yet coded in the BIC.

### NOTICE

This information has been carefully prepared. However, the procedure described is constantly being further developed. We reserve the right to revise and change procedures and documentation at any time and without prior notice. No claims for changes can be made from the information, illustrations and descriptions in this information.

### 7.3.4 Electronic access to the BIC (eBIC)

#### Electronic BIC (eBIC)

The Beckhoff Identification Code (BIC) is applied to the outside of Beckhoff products in a visible place. If possible, it should also be electronically readable.

Decisive for the electronic readout is the interface via which the product can be electronically addressed.

#### K-bus devices (IP20, IP67)

Currently, no electronic storage and readout is planned for these devices.

#### EtherCAT devices (IP20, IP67)

All Beckhoff EtherCAT devices have a so-called ESI-EEPROM, which contains the EtherCAT identity with the revision number. Stored in it is the EtherCAT slave information, also colloquially known as ESI/XML configuration file for the EtherCAT master. See the corresponding chapter in the EtherCAT system manual ([Link](#)) for the relationships.

The eBIC is also stored in the ESI-EEPROM. The eBIC was introduced into the Beckhoff I/O production (terminals, box modules) from 2020; widespread implementation is expected in 2021.

The user can electronically access the eBIC (if existent) as follows:

- With all EtherCAT devices, the EtherCAT master (TwinCAT) can read the eBIC from the ESI-EEPROM
  - From TwinCAT 3.1 build 4024.11, the eBIC can be displayed in the online view.
  - To do this, check the checkbox "Show Beckhoff Identification Code (BIC)" under EtherCAT → Advanced Settings → Diagnostics:

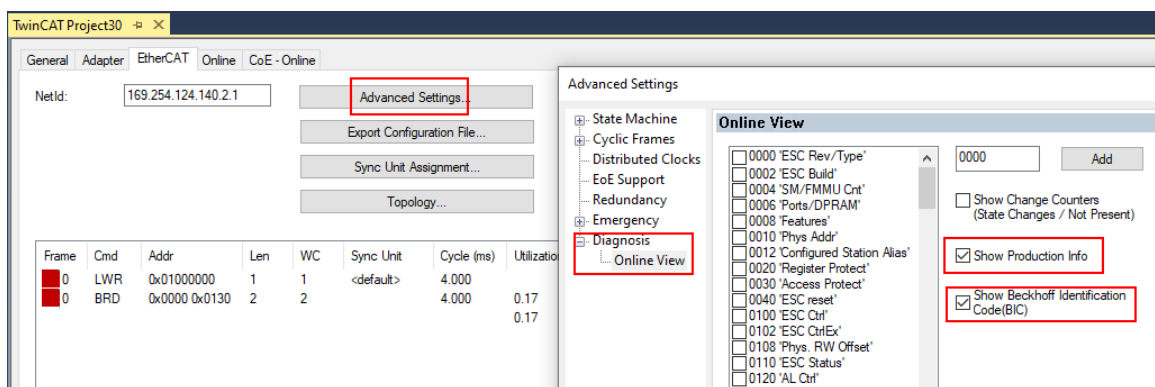

- The BTN and its contents are then displayed:

No	Addr	Name	State	CRC	Fw	Hw	Production Data	ItemNo	BTN	Description	Quantity	BatchNo	SerialNo
1	1001	Term 1 (EK1100)	OP	0.0	0	0	---						
2	1002	Term 2 (EL1018)	OP	0.0	0	0	2020 KW36 Fr	072222	k4p562d7	EL1809	1		678294
3	1003	Term 3 (EL3204)	OP	0.0	7	6	2012 KW24 Sa						
4	1004	Term 4 (EL2004)	OP	0.0	0	0	---	072223	k4p562d7	EL2004	1		678295
5	1005	Term 5 (EL1008)	OP	0.0	0	0	---						
6	1006	Term 6 (EL2008)	OP	0.0	0	12	2014 KW14 Mo						
7	1007	Term 7 (EK1110)	OP	0	1	8	2012 KW25 Mo						

- Note: as can be seen in the illustration, the production data HW version, FW version and production date, which have been programmed since 2012, can also be displayed with "Show Production Info".
- Access from the PLC: From TwinCAT 3.1. build 4024.24 the functions *FB\_EcReadBIC* and *FB\_EcReadBTN* are available in the Tc2\_EtherCAT Library from v3.3.19.0 for reading into the PLC..
- In the case of EtherCAT devices with CoE directory, the object 0x10E2:01 can additionally be used to display the device's own eBIC; the PLC can also simply access the information here:

- The device must be in PREOP/SAFEOP/OP for access:

Index	Name	Flags	Value
1000	Device type	RO	0x015E1389 (22942601)
1008	Device name	RO	ELM3704-0000
1009	Hardware version	RO	00
100A	Software version	RO	01
100B	Bootloader version	RO	J0.1.27.0
1011:0	Restore default parameters	RO	> 1 <
1018:0	Identity	RO	> 4 <
10E2:0	Manufacturer-specific Identification C...	RO	> 1 <
10E2:01	SubIndex 001	RO	1P158442SBTN0008jckp1KELM3704 Q1 2P482001000016
10F0:0	Backup parameter handling	RO	> 1 <
10F3:0	Diagnosis History	RO	> 21 <
10F8	Actual Time Stamp	RO	0x170bfb277e

- The object 0x10E2 will be introduced into stock products in the course of a necessary firmware revision.
- From TwinCAT 3.1. build 4024.24 the functions *FB\_EcCoEReadBIC* and *FB\_EcCoEReadBTN* are available in the *Tc2\_EtherCAT Library* from v3.3.19.0 for reading into the PLC.
- For processing the BIC/BTN data in the PLC, the following auxiliary functions are available in *Tc2\_Uilities* from TwinCAT 3.1 build 4024.24 onwards
  - *F\_SplitBIC*: The function splits the Beckhoff Identification Code (BIC) *sBICValue* into its components based on known identifiers and returns the recognized partial strings in a structure *ST\_SplitBIC* as return value.
  - *BIC\_TO\_BTN*: The function extracts the BTN from the BIC and returns it as a value.
- Note: in the case of electronic further processing, the BTN is to be handled as a string(8); the identifier "SBTN" is not part of the BTN.
- Technical background  
The new BIC information is additionally written as a category in the ESI-EEPROM during the device production. The structure of the ESI content is largely dictated by the ETG specifications, therefore the additional vendor-specific content is stored with the help of a category according to ETG.2010. ID 03 indicates to all EtherCAT masters that they must not overwrite these data in case of an update or restore the data after an ESI update.  
The structure follows the content of the BIC, see there. This results in a memory requirement of approx. 50..200 bytes in the EEPROM.
- Special cases
  - If multiple, hierarchically arranged ESCs are installed in a device, only the top-level ESC carries the eBIC Information.
  - If multiple, non-hierarchically arranged ESCs are installed in a device, all ESCs carry the eBIC Information.
  - If the device consists of several sub-devices with their own identity, but only the top-level device is accessible via EtherCAT, the eBIC of the top-level device is located in the CoE object directory 0x10E2:01 and the eBICs of the sub-devices follow in 0x10E2:nn.

### PROFIBUS, PROFINET, DeviceNet devices etc.

Currently, no electronic storage and readout is planned for these devices.

## 7.4 Support and Service

Beckhoff and their partners around the world offer comprehensive support and service, making available fast and competent assistance with all questions related to Beckhoff products and system solutions.

### Beckhoff's branch offices and representatives

Please contact your Beckhoff branch office or representative for local support and service on Beckhoff products!

The addresses of Beckhoff's branch offices and representatives round the world can be found on her internet pages: [www.beckhoff.com](http://www.beckhoff.com)

You will also find further documentation for Beckhoff components there.

### Support

The Beckhoff Support offers you comprehensive technical assistance, helping you not only with the application of individual Beckhoff products, but also with other, wide-ranging services:

- support
- design, programming and commissioning of complex automation systems
- and extensive training program for Beckhoff system components

Hotline: +49 5246 963 157  
e-mail: [support@beckhoff.com](mailto:support@beckhoff.com)  
web: [www.beckhoff.com/support](http://www.beckhoff.com/support)

### Service

The Beckhoff Service Center supports you in all matters of after-sales service:

- on-site service
- repair service
- spare parts service
- hotline service

Hotline: +49 5246 963 460  
e-mail: [service@beckhoff.com](mailto:service@beckhoff.com)  
web: [www.beckhoff.com/service](http://www.beckhoff.com/service)

### Headquarters Germany

Beckhoff Automation GmbH & Co. KG

Hülshorstweg 20  
33415 Verl  
Germany

Phone: +49 5246 963 0  
e-mail: [info@beckhoff.com](mailto:info@beckhoff.com)  
web: [www.beckhoff.com](http://www.beckhoff.com)





Beckhoff Automation GmbH & Co. KG  
Hülshorstweg 20  
33415 Verl  
Germany  
Phone: +49 5246 9630  
[info@beckhoff.com](mailto:info@beckhoff.com)  
[www.beckhoff.com](http://www.beckhoff.com)