

Documentation | EN

KL6771/KS6771

MP-Bus Master Terminals

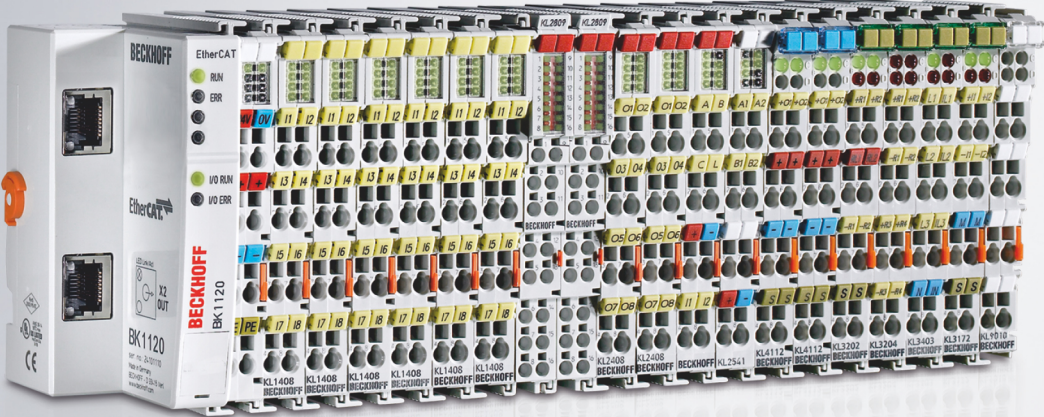

Table of contents

1 Foreword	5
1.1 Notes on the documentation	5
1.2 Safety instructions	6
1.3 Documentation Issue Status	7
2 Product overview	8
2.1 KL6771/KS6771 - Introduction	8
2.2 Technical Data	9
2.3 Basic Function Principles	10
2.4 MP-Bus	11
2.4.1 Introduction	11
2.4.2 Topology	11
3 Mounting and wiring	12
3.1 Instructions for ESD protection	12
3.2 Installation on mounting rails.....	13
3.3 Disposal	15
3.4 Installation instructions for enhanced mechanical load capacity.....	16
3.5 Connection	17
3.5.1 Connection system.....	17
3.5.2 Wiring.....	18
3.5.3 Contact assignment	20
3.5.4 Diagnostic LEDs.....	21
3.5.5 MP-Bus cabling.....	22
3.6 ATEX - Special conditions (standard temperature range).....	24
3.7 Continuative documentation for ATEX and IECEx.....	25
4 Programming	26
4.1 TwinCAT libraries.....	26
5 Appendix	27
5.1 Beckhoff Identification Code (BIC).....	27
5.2 Support and Service.....	29

1 Foreword

1.1 Notes on the documentation

Intended audience

This description is only intended for the use of trained specialists in control and automation engineering who are familiar with the applicable national standards.

It is essential that the documentation and the following notes and explanations are followed when installing and commissioning these components.

It is the duty of the technical personnel to use the documentation published at the respective time of each installation and commissioning.

The responsible staff must ensure that the application or use of the products described satisfy all the requirements for safety, including all the relevant laws, regulations, guidelines and standards.

Disclaimer

The documentation has been prepared with care. The products described are, however, constantly under development.

We reserve the right to revise and change the documentation at any time and without prior announcement.

No claims for the modification of products that have already been supplied may be made on the basis of the data, diagrams and descriptions in this documentation.

Trademarks

Beckhoff®, TwinCAT®, TwinCAT/BSD®, TC/BSD®, EtherCAT®, EtherCAT G®, EtherCAT G10®, EtherCAT P®, Safety over EtherCAT®, TwinSAFE®, XFC®, XTS® and XPlanar® are registered trademarks of and licensed by Beckhoff Automation GmbH. Other designations used in this publication may be trademarks whose use by third parties for their own purposes could violate the rights of the owners.

Patent Pending

The EtherCAT Technology is covered, including but not limited to the following patent applications and patents: EP1590927, EP1789857, EP1456722, EP2137893, DE102015105702 with corresponding applications or registrations in various other countries.

The logo for EtherCAT, featuring the word "EtherCAT" in a bold, black, sans-serif font. A red arrow points from the top of the "A" towards the right, ending above the "T". A registered trademark symbol (®) is located to the right of the "T".

EtherCAT® is registered trademark and patented technology, licensed by Beckhoff Automation GmbH, Germany.

Copyright

© Beckhoff Automation GmbH & Co. KG, Germany.

The reproduction, distribution and utilization of this document as well as the communication of its contents to others without express authorization are prohibited.

Offenders will be held liable for the payment of damages. All rights reserved in the event of the grant of a patent, utility model or design.

1.2 Safety instructions

Safety regulations

Please note the following safety instructions and explanations!
Product-specific safety instructions can be found on following pages or in the areas mounting, wiring, commissioning etc.

Exclusion of liability

All the components are supplied in particular hardware and software configurations appropriate for the application. Modifications to hardware or software configurations other than those described in the documentation are not permitted, and nullify the liability of Beckhoff Automation GmbH & Co. KG.

Personnel qualification

This description is only intended for trained specialists in control, automation and drive engineering who are familiar with the applicable national standards.

Description of instructions

In this documentation the following instructions are used.
These instructions must be read carefully and followed without fail!

DANGER

Serious risk of injury!

Failure to follow this safety instruction directly endangers the life and health of persons.

WARNING

Risk of injury!

Failure to follow this safety instruction endangers the life and health of persons.

CAUTION

Personal injuries!

Failure to follow this safety instruction can lead to injuries to persons.

NOTE

Damage to environment/equipment or data loss

Failure to follow this instruction can lead to environmental damage, equipment damage or data loss.



Tip or pointer

This symbol indicates information that contributes to better understanding.

1.3 Documentation Issue Status

Version	Comment
2.1.0	<ul style="list-style-type: none"> • Chapter <i>Technical data</i> updated • Ex markings added to technical data • Chapter <i>Instructions for ESD protection</i> added • Chapter <i>Disposal</i> added • Chapter <i>Beckhoff Identification Code (BIC)</i> added • Document structure updated • Links to TwinCAT libraries updated • New title page
2.0.0	<ul style="list-style-type: none"> • Migration • Chapter <i>MP-bus wiring</i> updated
1.4.0	<ul style="list-style-type: none"> • Chapter <i>MP-bus wiring</i> updated • Foreword updated • Technical data updated
1.3.0	<ul style="list-style-type: none"> • <i>MP-bus wiring</i> chapter updated: From firmware version B3, the MP-bus master terminal can also be used in cablings with 24 V_{AC}. • Chapter <i>TwinCAT libraries</i> revised.
1.2.0	<ul style="list-style-type: none"> • Programming description moved to the Beckhoff Information System [► 26] • TwinCAT library TcMPBus (formerly TcKL6771) updated to version 1.8.0 • ATEX notes added
1.1.0	<ul style="list-style-type: none"> • UST-3 implemented • TwinCAT library TcKL6771 updated to version 1.005.000 • Installation notes updated
1.0.1	Sample programs updated
1.0.0	First release

Firmware and hardware versions

Documentation Version	KL6771, KS6771	
	Firmware	Hardware
2.1.0	B3	07
2.0.0	B3	06
1.4.0	B3	06
1.3.0	B3	05
1.2.0	B2	02
1.1.0	B2	01
1.0.1	B1	00
1.0.0	B1	00

The firmware and hardware versions (delivery state) of the terminal can be found in the serial number printed on the side.

Syntax of the serial number

Structure of the serial number: WW YY FF HH

WW - week of production (calendar week)

YY - year of production

FF - firmware version

HH - hardware version

Example with serial number 33 06 B1 00:

33 - week of production 33

06 - year of production 2006

B1 - firmware version B1

00 - hardware version 00

2 Product overview

2.1 KL6771/KS6771 - Introduction

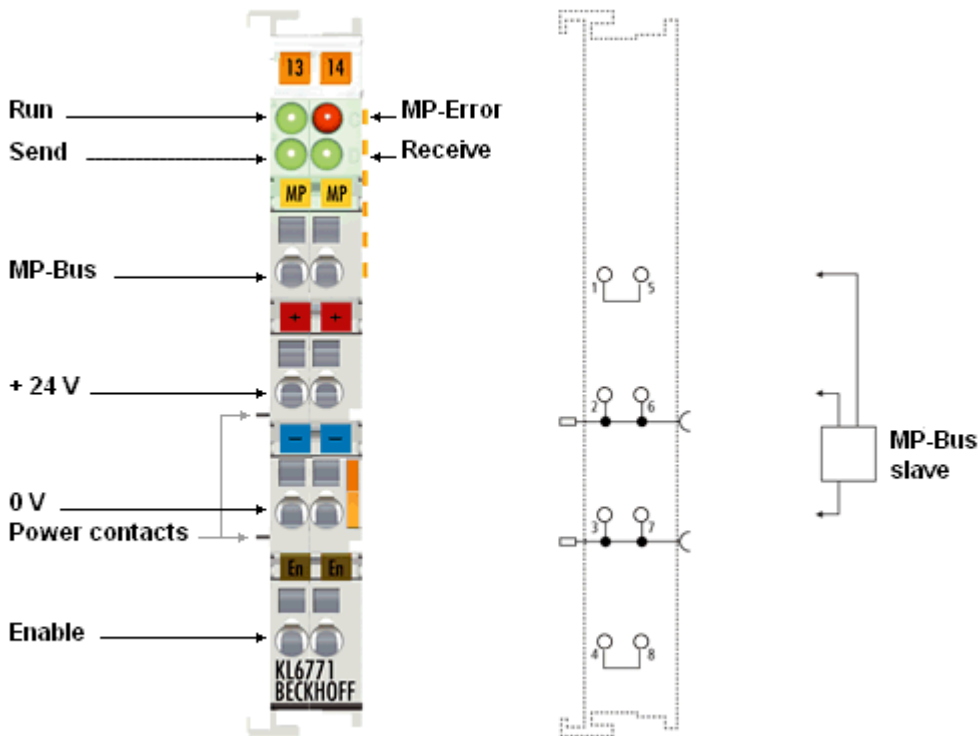

Fig. 1: KL6771 - MP-bus master terminal

The KL6771/KS6771 MP-bus master terminal enables direct connection of MP-bus slaves. The MP-Bus was developed by Belimo for connecting valves, throttle valves, air valves, fire dampers, and for window ventilation systems. Up to 16 field devices, 8 drives and 8 sensors can be connected to the KL6771/KS6771. Process data exchange is fieldbus-independent. The Bus Terminal is configured and commissioned via TwinCAT function blocks. Status LEDs directly indicate the bus status. Several KL6771/KS6771 Bus Terminals can be connected to the same Bus Coupler or Bus Terminal Controller.

2.2 Technical Data

Technical Data	KL6771	KS6771
Master channels	1	
Transmission standard	MP-bus standard	
Number of slaves	max. 16 (8 actuators and 8 sensors)	
Data transfer rate	1200 baud	
Electrical isolation	500 V (K-bus / MP-bus)	
Power supply for the electronics	via the K-bus and through the power contacts	
Current consumption from the K-bus	typically 55 mA	
Current consumption from power contacts	typically 10 mA + current consumption of the connected MP-bus slaves	
Output process image	12 bytes data	
Process image of the inputs	12 bytes data	
Weight	approx. 85 g	
Dimensions (W x H x D)	approx. 12 mm x 100 mm x 70 mm	
Mounting [▶ 13]	on 35 mm mounting rail conforms to EN 60715	
Pluggable wiring	no	yes
Permissible ambient temperature range during operation	0°C ... + 55°C	
Permissible ambient temperature range during storage	-25 °C ... + 85 °C	
Permissible relative air humidity	95 %, no condensation	
Enhanced mechanical load capacity	yes, see also installation instructions ▶ 16 for terminals with enhanced mechanical load capacity	
Vibration / shock resistance	conforms to EN 60068-2-6 / EN 60068-2-27	
EMC immunity / emission	conforms to EN 61000-6-2 / EN 61000-6-4	
Protection class	IP20	
Installation position	variable	
Pluggable wiring	no	yes
Approvals/markings*	CE, UKCA, cULus, EAC, ATEX ▶ 24	

*) Real applicable approvals/markings see type plate on the side (product marking).

Ex marking

Standard	Marking
ATEX	II 3 G Ex nA IIC T4 Gc

2.3 Basic Function Principles

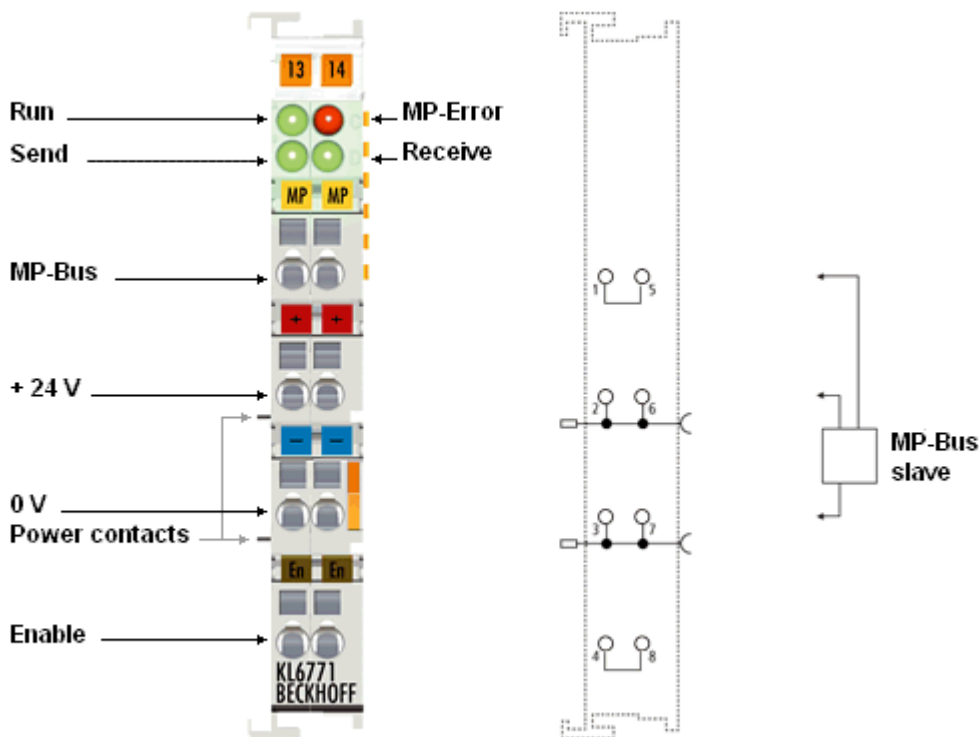

Fig. 2: Basic Function Principles

Operation of the MP-bus Bus Terminal requires function blocks that are available for [download](#) [► 26].

The following drives and sensors are supported:

- VAVs (e.g. NMV-D2M)
- FLS window opener
- Flap and positioning actuators (e.g. NM24-MFT2, NV23-MFT2)
- Fire dampers (e.g. BF24TL-T-ST)
- PTH sensors

There is a function block that carries out communication with the device for each of these drives or sensors.

The MP-Bus slave is addressed through an addressing block. The slaves can be addressed manually or automatically.

Software required for use of the KL6771

TwinCAT PLC has a corresponding library for addressing the KL6771 from within the application.

● Required TwinCAT library

i TwinCAT supports the KL6771 with its own library. If the KL6771 is to be used with an external controller, a Bus Terminal controller (BC or BX) is required on which the MP-Bus library can run. Operation of the KL6771 on a PC or CX without TwinCAT PLC is not supported!

2.4 MP-Bus

2.4.1 Introduction

MP-bus = multi-point bus

The MP-Bus (Multi-Point) is a simple sensor/actuator bus, which is used for certain sub-systems of the building automation system. The MP-Bus serves to control HVAC actuators for flaps, control valves and volume flow regulators from the Belimo product range. Up to eight different devices from HVAC systems can be connected to an MP-Bus master using 3-wire technology. Additionally, a sensor can be connected to each of these eight devices; the sensor is addressed by the MP-Bus. An additional range of products with an MP-Bus connection is the FLS window ventilation system by Belimo (see Belimo documentation for the connection of the Belimo drives).

The MP-Bus was developed by Belimo for connecting valves, throttle valves, air valves, fire dampers, and for window ventilation systems.

2.4.2 Topology

There are no restrictions in terms of the topological configuration of the MP-bus strands: Star, ring, tree or mixed topologies are possible. The length of the entire bus strand depends on the selected cable cross-section and the type as well as the number of connected drives! The documentation from the Belimo company contains further information.

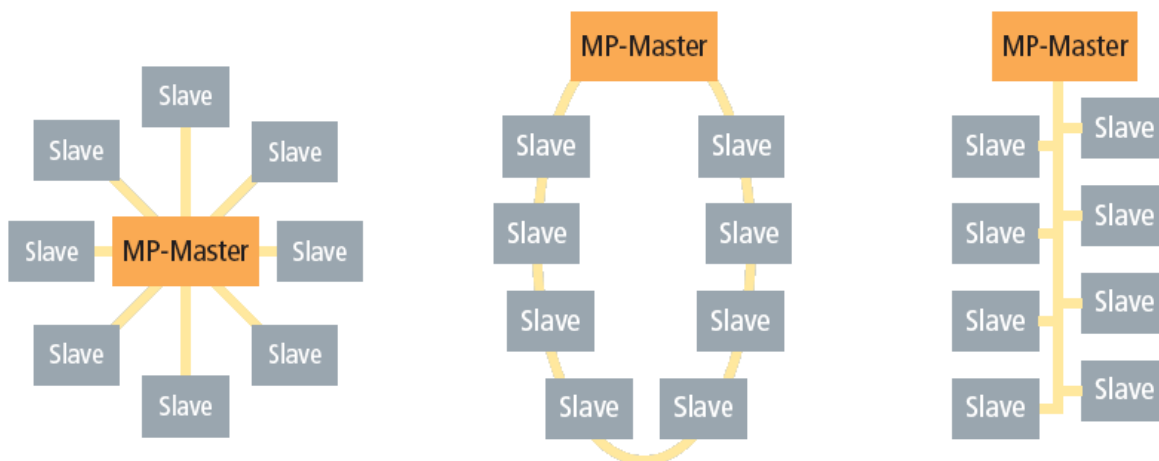

Fig. 3: MP-bus topologies

3 Mounting and wiring

3.1 Instructions for ESD protection

NOTE

Destruction of the devices by electrostatic discharge possible!

The devices contain components at risk from electrostatic discharge caused by improper handling.

- Please ensure you are electrostatically discharged and avoid touching the contacts of the device directly.
- Avoid contact with highly insulating materials (synthetic fibers, plastic film etc.).
- Surroundings (working place, packaging and personnel) should be grounded probably, when handling with the devices.
- Each assembly must be terminated at the right hand end with a KL9010 bus end terminal, to ensure the protection class and ESD protection.

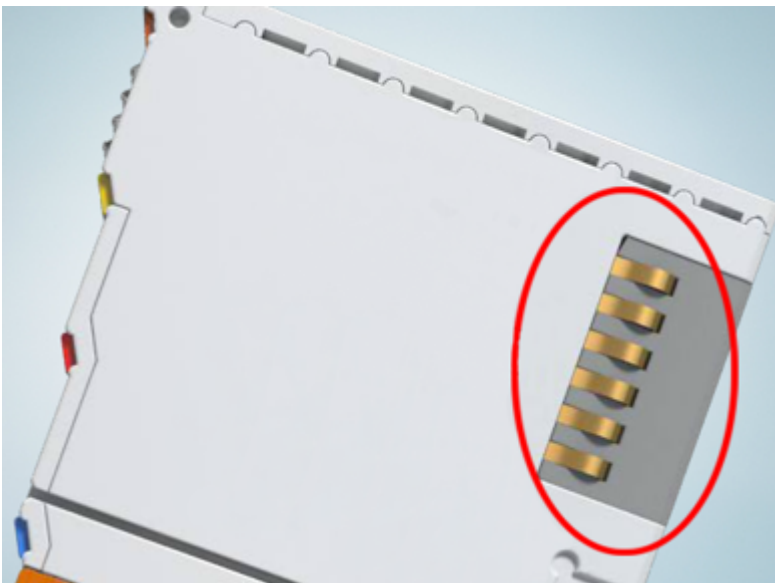

Fig. 4: Spring contacts of the Beckhoff I/O components

3.2 Installation on mounting rails

⚠ WARNING

Risk of electric shock and damage of device!

Bring the bus terminal system into a safe, powered down state before starting installation, disassembly or wiring of the bus terminals!

Assembly

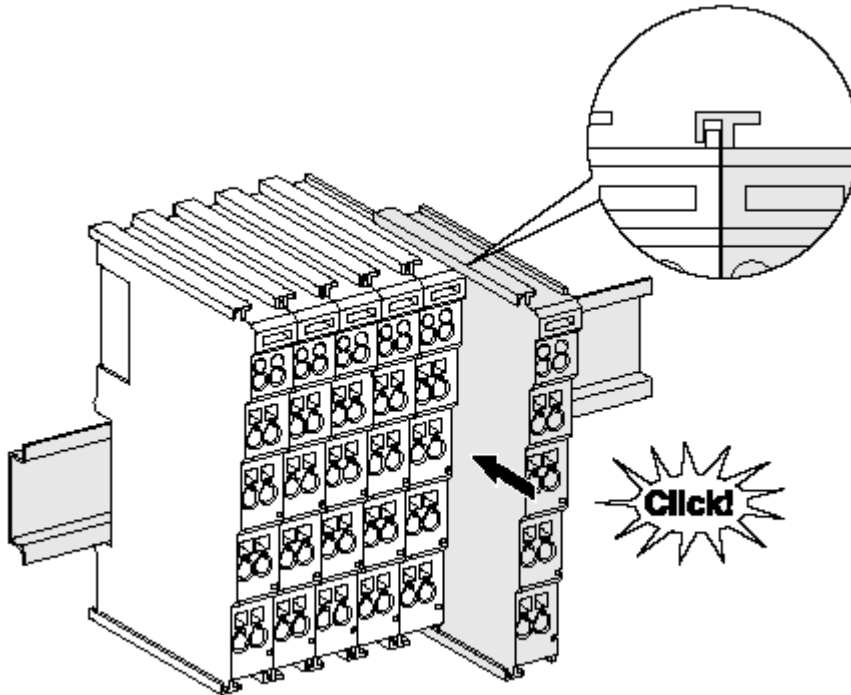

Fig. 5: Attaching on mounting rail

The bus coupler and bus terminals are attached to commercially available 35 mm mounting rails (DIN rails according to EN 60715) by applying slight pressure:

1. First attach the fieldbus coupler to the mounting rail.
2. The bus terminals are now attached on the right-hand side of the fieldbus coupler. Join the components with tongue and groove and push the terminals against the mounting rail, until the lock clicks onto the mounting rail.

If the terminals are clipped onto the mounting rail first and then pushed together without tongue and groove, the connection will not be operational! When correctly assembled, no significant gap should be visible between the housings.

i Fixing of mounting rails

The locking mechanism of the terminals and couplers extends to the profile of the mounting rail. At the installation, the locking mechanism of the components must not come into conflict with the fixing bolts of the mounting rail. To mount the mounting rails with a height of 7.5 mm under the terminals and couplers, you should use flat mounting connections (e.g. countersunk screws or blind rivets).

Disassembly

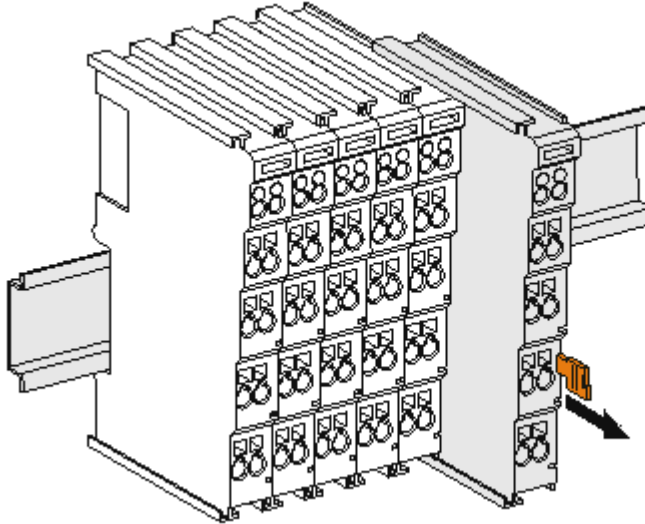

Fig. 6: Disassembling of terminal

Each terminal is secured by a lock on the mounting rail, which must be released for disassembly:

1. Pull the terminal by its orange-colored lugs approximately 1 cm away from the mounting rail. In doing so for this terminal the mounting rail lock is released automatically and you can pull the terminal out of the bus terminal block easily without excessive force.
2. Grasp the released terminal with thumb and index finger simultaneous at the upper and lower grooved housing surfaces and pull the terminal out of the bus terminal block.

Connections within a bus terminal block

The electric connections between the Bus Coupler and the Bus Terminals are automatically realized by joining the components:

- The six spring contacts of the K-Bus/E-Bus deal with the transfer of the data and the supply of the Bus Terminal electronics.
- The power contacts deal with the supply for the field electronics and thus represent a supply rail within the bus terminal block. The power contacts are supplied via terminals on the Bus Coupler (up to 24 V) or for higher voltages via power feed terminals.

● Power Contacts

i During the design of a bus terminal block, the pin assignment of the individual Bus Terminals must be taken account of, since some types (e.g. analog Bus Terminals or digital 4-channel Bus Terminals) do not or not fully loop through the power contacts. Power Feed Terminals (KL91xx, KL92xx or EL91xx, EL92xx) interrupt the power contacts and thus represent the start of a new supply rail.

PE power contact

The power contact labeled PE can be used as a protective earth. For safety reasons this contact mates first when plugging together, and can ground short-circuit currents of up to 125 A.

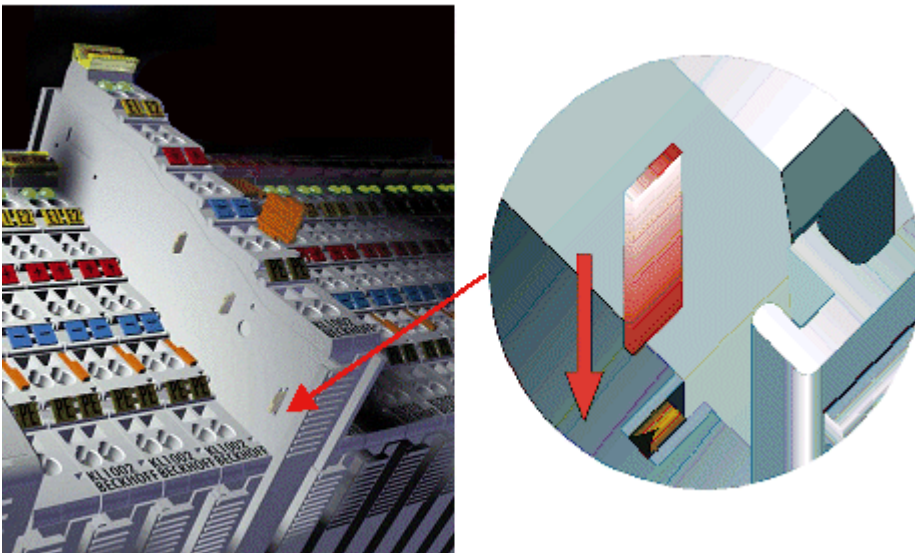

Fig. 7: Power contact on left side

NOTE

Possible damage of the device

Note that, for reasons of electromagnetic compatibility, the PE contacts are capacitatively coupled to the mounting rail. This may lead to incorrect results during insulation testing or to damage on the terminal (e.g. disruptive discharge to the PE line during insulation testing of a consumer with a nominal voltage of 230 V). For insulation testing, disconnect the PE supply line at the Bus Coupler or the Power Feed Terminal! In order to decouple further feed points for testing, these Power Feed Terminals can be released and pulled at least 10 mm from the group of terminals.

⚠ WARNING

Risk of electric shock!

The PE power contact must not be used for other potentials!

3.3 Disposal



Products marked with a crossed-out wheeled bin shall not be discarded with the normal waste stream. The device is considered as waste electrical and electronic equipment. The national regulations for the disposal of waste electrical and electronic equipment must be observed.

3.4 Installation instructions for enhanced mechanical load capacity

⚠ WARNING

Risk of injury through electric shock and damage to the device!

Bring the Bus Terminal system into a safe, de-energized state before starting mounting, disassembly or wiring of the Bus Terminals!

Additional checks

The terminals have undergone the following additional tests:

Verification	Explanation
Vibration	10 frequency runs in 3 axes
	6 Hz < f < 60 Hz displacement 0.35 mm, constant amplitude
	60.1 Hz < f < 500 Hz acceleration 5 g, constant amplitude
Shocks	1000 shocks in each direction, in 3 axes
	25 g, 6 ms

Additional installation instructions

For terminals with enhanced mechanical load capacity, the following additional installation instructions apply:

- The enhanced mechanical load capacity is valid for all permissible installation positions
- Use a mounting rail according to EN 60715 TH35-15
- Fix the terminal segment on both sides of the mounting rail with a mechanical fixture, e.g. an earth terminal or reinforced end clamp
- The maximum total extension of the terminal segment (without coupler) is:
64 terminals (12 mm mounting with) or 32 terminals (24 mm mounting with)
- Avoid deformation, twisting, crushing and bending of the mounting rail during edging and installation of the rail
- The mounting points of the mounting rail must be set at 5 cm intervals
- Use countersunk head screws to fasten the mounting rail
- The free length between the strain relief and the wire connection should be kept as short as possible. A distance of approx. 10 cm should be maintained to the cable duct.

3.5 Connection

3.5.1 Connection system

⚠ WARNING

Risk of electric shock and damage of device!

Bring the bus terminal system into a safe, powered down state before starting installation, disassembly or wiring of the bus terminals!

Overview

The bus terminal system offers different connection options for optimum adaptation to the respective application:

- The terminals of ELxxxx and KLxxxx series with standard wiring include electronics and connection level in a single enclosure.
- The terminals of ESxxxx and KSxxxx series feature a pluggable connection level and enable steady wiring while replacing.
- The High Density Terminals (HD Terminals) include electronics and connection level in a single enclosure and have advanced packaging density.

Standard wiring (ELxxxx / KLxxxx)



Fig. 8: Standard wiring

The terminals of ELxxxx and KLxxxx series have been tried and tested for years. They feature integrated screwless spring force technology for fast and simple assembly.

Pluggable wiring (ESxxxx / KSxxxx)



Fig. 9: Pluggable wiring

The terminals of ESxxxx and KSxxxx series feature a pluggable connection level. The assembly and wiring procedure is the same as for the ELxxxx and KLxxxx series. The pluggable connection level enables the complete wiring to be removed as a plug connector from the top of the housing for servicing. The lower section can be removed from the terminal block by pulling the unlocking tab. Insert the new component and plug in the connector with the wiring. This reduces the installation time and eliminates the risk of wires being mixed up.

The familiar dimensions of the terminal only had to be changed slightly. The new connector adds about 3 mm. The maximum height of the terminal remains unchanged.

A tab for strain relief of the cable simplifies assembly in many applications and prevents tangling of individual connection wires when the connector is removed.

Conductor cross sections between 0.08 mm² and 2.5 mm² can continue to be used with the proven spring force technology.

The overview and nomenclature of the product names for ESxxxx and KSxxxx series has been retained as known from ELxxxx and KLxxxx series.

High Density Terminals (HD Terminals)



Fig. 10: High Density Terminals

The terminals from these series with 16 terminal points are distinguished by a particularly compact design, as the packaging density is twice as large as that of the standard 12 mm bus terminals. Massive conductors and conductors with a wire end sleeve can be inserted directly into the spring loaded terminal point without tools.

● Wiring HD Terminals



The High Density Terminals of the ELx8xx and KLx8xx series doesn't support pluggable wiring.

Ultrasonically “bonded” (ultrasonically welded) conductors

● Ultrasonically “bonded” conductors



It is also possible to connect the Standard and High Density Terminals with ultrasonically “bonded” (ultrasonically welded) conductors. In this case, please note the tables concerning the [wire-size width](#) [► 19]!

3.5.2 Wiring

⚠ WARNING

Risk of electric shock and damage of device!

Bring the bus terminal system into a safe, powered down state before starting installation, disassembly or wiring of the bus terminals!

Terminals for standard wiring ELxxxx/KLxxxx and for pluggable wiring ESxxxx/KSxxxx

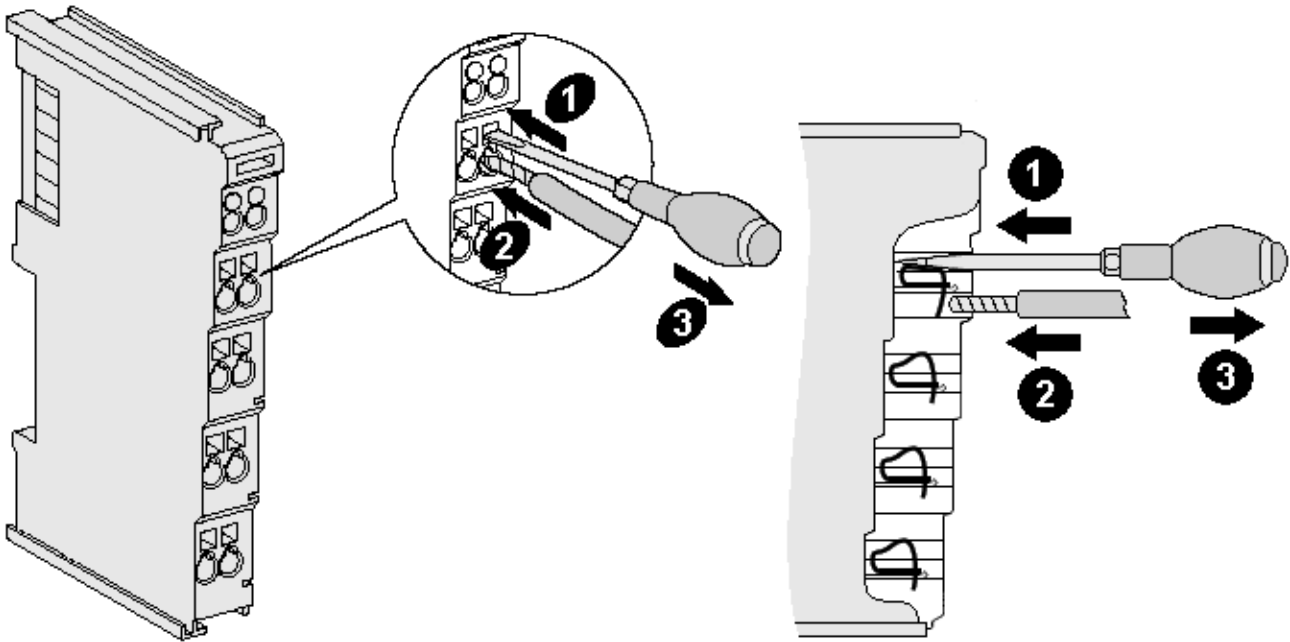

Fig. 11: Connecting a cable on a terminal point

Up to eight terminal points enable the connection of solid or finely stranded cables to the bus terminal. The terminal points are implemented in spring force technology. Connect the cables as follows:

1. Open a terminal point by pushing a screwdriver straight against the stop into the square opening above the terminal point. Do not turn the screwdriver or move it alternately (don't toggle).
2. The wire can now be inserted into the round terminal opening without any force.
3. The terminal point closes automatically when the pressure is released, holding the wire securely and permanently.

See the following table for the suitable wire size width.

Terminal housing	ELxxxx, KLxxxx	ESxxxx, KSxxxx
Wire size width (single core wires)	0.08 ... 2.5 mm ²	0.08 ... 2.5 mm ²
Wire size width (fine-wire conductors)	0.08 ... 2.5 mm ²	0.08 ... 2.5 mm ²
Wire size width (conductors with a wire end sleeve)	0.14 ... 1.5 mm ²	0.14 ... 1.5 mm ²
Wire stripping length	8 ... 9 mm	9 ... 10 mm

High Density Terminals (HD Terminals [▶ 18]) with 16 terminal points

The conductors of the HD Terminals are connected without tools for single-wire conductors using the direct plug-in technique, i.e. after stripping the wire is simply plugged into the terminal point. The cables are released, as usual, using the contact release with the aid of a screwdriver. See the following table for the suitable wire size width.

Terminal housing	High Density Housing
Wire size width (single core wires)	0.08 ... 1.5 mm ²
Wire size width (fine-wire conductors)	0.25 ... 1.5 mm ²
Wire size width (conductors with a wire end sleeve)	0.14 ... 0.75 mm ²
Wire size width (ultrasonically "bonded" conductors)	only 1.5 mm ² (see notice [▶ 18])
Wire stripping length	8 ... 9 mm

3.5.3 Contact assignment

⚠ WARNING

Risk of injury through electric shock and damage to the device!

Bring the Bus Terminals system into a safe, de-energized state before starting mounting, disassembly or wiring of the Bus Terminals!

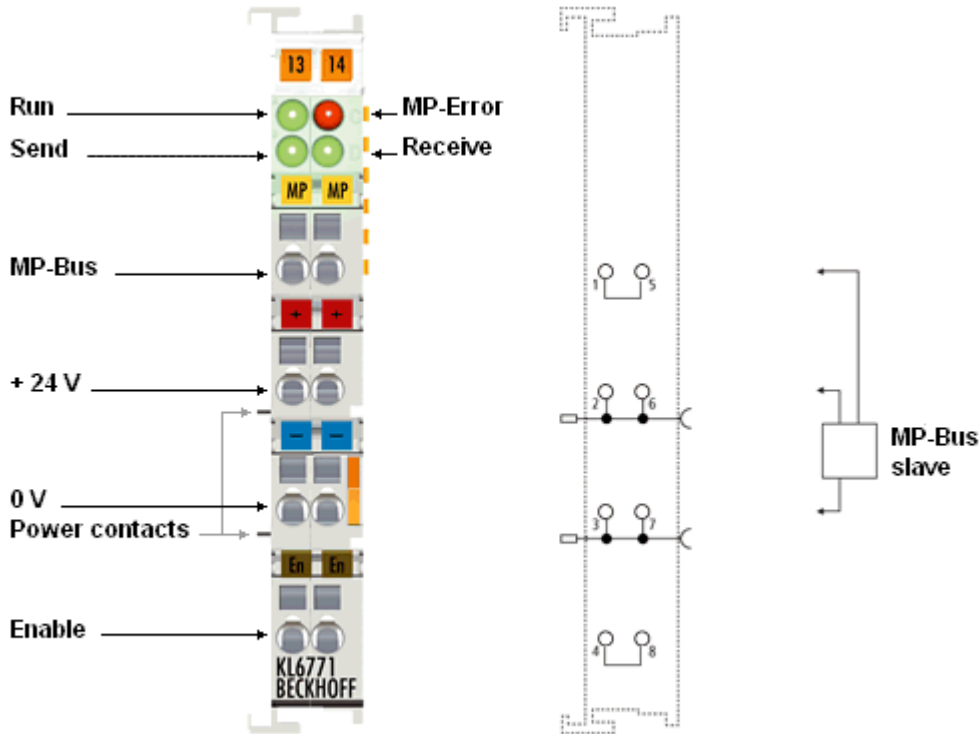

Fig. 12: Contact assignment

Terminal point	No.	Connection for
MP-Bus	1	Cable 5 (white or orange)
+ 24 V _{DC} (+)	2	Cable 2 (red)
0 V (-)	3	Cable 1 (black)
Enable	4	Deactivates the MP-Bus master on the KL6771
MP-Bus	5	Cable 5 (white or orange)
+ 24 V _{DC} (+)	6	Cable 2 (red)
0 V (-)	7	Cable 1 (black)
Enable	8	Deactivates the MP-Bus master on the KL6771

● Enable input

i If 24 V_{DC} is applied to the Enable input, the KL6771 will halt the MP-Bus communication. The higher-level PLC receives a message, and the MP Error LED lights up.

3.5.4 Diagnostic LEDs

The LEDs indicate the operating state of the KL6771.

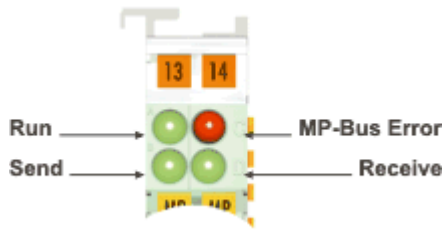

Fig. 13: Diagnostic LEDs

Meaning of the LED display

LED	Color	Channel	State and significance		
			On	off	flashes
K-Bus Run	green	1	Lit, either weakly or strongly: K-bus communication OK	No K-Bus communication	K-Bus communication
MP-Bus Error	red		<ul style="list-style-type: none"> • Enable input is set • PLC program has not started, or MP-Bus function block is not accessing the KL6771 	No error	Error detected
Send	green		Toggles when an MP telegram is sent	-	Data is being sent
Receive	green		Toggles when an MP telegram is received	-	Data is being received

3.5.5 MP-Bus cabling

⚠ WARNING

Risk of injury through electric shock and damage to the device!

Bring the Bus Terminals system into a safe, de-energized state before starting mounting, disassembly or wiring of the Bus Terminals!

Maximum MP-bus length

The maximum cable length is obtained by considering the following points:

- The total of the power figures for all the connected bus devices
- Wire cross-section
- AC (from firmware version B3) or DC

Operation of MP-bus slaves (actuators) with DC power supply

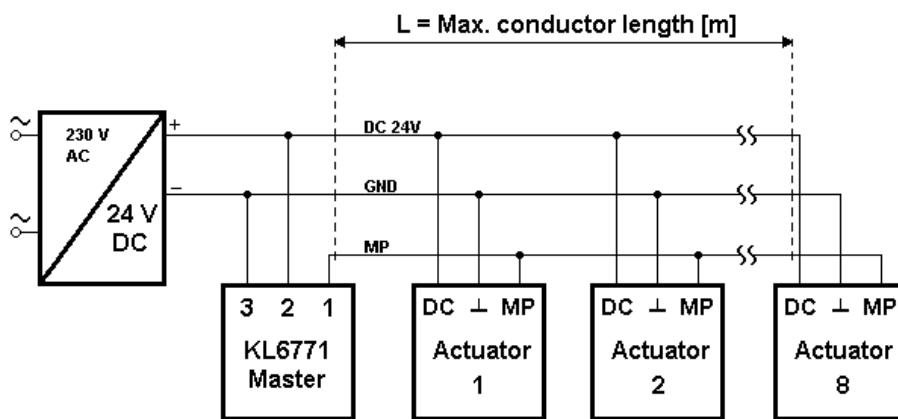

Fig. 14: Operation of MP-bus slaves (actuators) with DC power supply

Operation of MP-bus slaves (actuators) with AC power supply

(from firmware version B3)

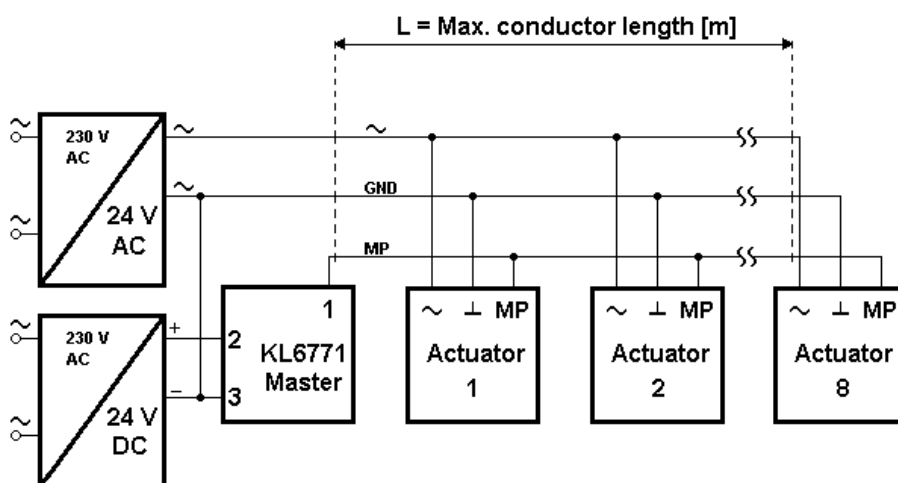

Fig. 15: Operation of MP-bus slaves (actuators) with AC power supply

The upper power supply unit supplies the actuators with AC voltage.

The lower power supply unit supplies the MP-bus master terminal (via the power contacts of the BK, BC, BX or CX).

MP-Bus length in relation to the effective power of all drives

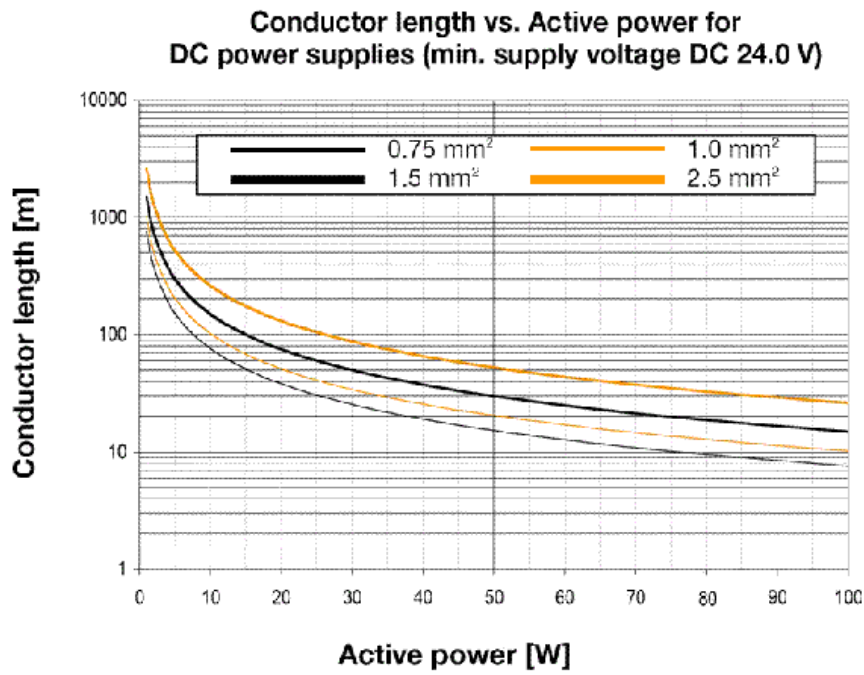

Fig. 16: MP-Bus length in relation to the effective power of all drives

Example with 4 drives

$$W_{total} = 1.3 \text{ W} + 2.5 \text{ W} + 6.0 \text{ W} + 3.0 \text{ W} = 12.8 \text{ W}$$

Wire cross-section in mm ²	Maximum bus length
0.75	60 m
1.00	80 m
1.5	115 m
2.5	200 m

3.6 ATEX - Special conditions (standard temperature range)

⚠ WARNING

Observe the special conditions for the intended use of Beckhoff fieldbus components with standard temperature range in potentially explosive areas (directive 2014/34/EU)!

- The certified components are to be installed in a suitable housing that guarantees a protection class of at least IP54 in accordance with EN 60079-15! The environmental conditions during use are thereby to be taken into account!
- For dust (only the fieldbus components of certificate no. KEMA 10ATEX0075 X Issue 9): The equipment shall be installed in a suitable enclosure providing a degree of protection of IP54 according to EN 60079-31 for group IIIA or IIIB and IP6X for group IIIC, taking into account the environmental conditions under which the equipment is used!
- If the temperatures during rated operation are higher than 70°C at the feed-in points of cables, lines or pipes, or higher than 80°C at the wire branching points, then cables must be selected whose temperature data correspond to the actual measured temperature values!
- Observe the permissible ambient temperature range of 0 to 55°C for the use of Beckhoff fieldbus components standard temperature range in potentially explosive areas!
- Measures must be taken to protect against the rated operating voltage being exceeded by more than 40% due to short-term interference voltages!
- The individual terminals may only be unplugged or removed from the Bus Terminal system if the supply voltage has been switched off or if a non-explosive atmosphere is ensured!
- The connections of the certified components may only be connected or disconnected if the supply voltage has been switched off or if a non-explosive atmosphere is ensured!
- The fuses of the KL92xx/EL92xx power feed terminals may only be exchanged if the supply voltage has been switched off or if a non-explosive atmosphere is ensured!
- Address selectors and ID switches may only be adjusted if the supply voltage has been switched off or if a non-explosive atmosphere is ensured!

Standards

The fundamental health and safety requirements are fulfilled by compliance with the following standards:

- EN 60079-0:2012+A11:2013
- EN 60079-15:2010
- EN 60079-31:2013 (only for certificate no. KEMA 10ATEX0075 X Issue 9)

Marking

The Beckhoff fieldbus components with standard temperature range certified according to the ATEX directive for potentially explosive areas bear one of the following markings:



II 3G KEMA 10ATEX0075 X Ex nA IIC T4 Gc Ta: 0 ... +55°C

II 3D KEMA 10ATEX0075 X Ex tc IIIC T135°C Dc Ta: 0 ... +55°C
(only for fieldbus components of certificate no. KEMA 10ATEX0075 X Issue 9)

or



II 3G KEMA 10ATEX0075 X Ex nA nC IIC T4 Gc Ta: 0 ... +55°C

II 3D KEMA 10ATEX0075 X Ex tc IIIC T135°C Dc Ta: 0 ... +55°C
(only for fieldbus components of certificate no. KEMA 10ATEX0075 X Issue 9)

3.7 Continulative documentation for ATEX and IECEx

NOTE**Continulative documentation about explosion protection according to ATEX and IECEx**

Pay also attention to the continuative documentation

Ex. Protection for Terminal Systems

Notes on the use of the Beckhoff terminal systems in hazardous areas according to ATEX and IECEx,

that is available for [download](#) within the download area of your product on the Beckhoff homepage www.beckhoff.com!

4 Programming

4.1 TwinCAT libraries

Software documentation in the Beckhoff Information System:

TwinCAT 2: [TwinCAT 2 | PLC Lib: TcMPBus](#)

TwinCAT 3: [TwinCAT 3 | PLC Lib: Tc2 MPBus](#)

5 Appendix

5.1 Beckhoff Identification Code (BIC)

The Beckhoff Identification Code (BIC) is increasingly being applied to Beckhoff products to uniquely identify the product. The BIC is represented as a Data Matrix Code (DMC, code scheme ECC200), the content is based on the ANSI standard MH10.8.2-2016.

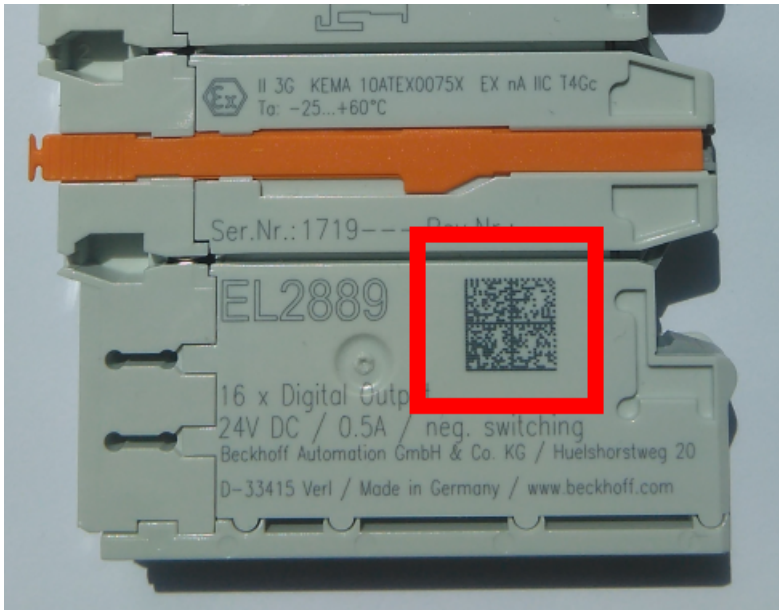

Fig. 17: BIC as data matrix code (DMC, code scheme ECC200)

The BIC will be introduced step by step across all product groups.

Depending on the product, it can be found in the following places:

- on the packaging unit
- directly on the product (if space suffices)
- on the packaging unit and the product

The BIC is machine-readable and contains information that can also be used by the customer for handling and product management.

Each piece of information can be uniquely identified using the so-called data identifier (ANSI MH10.8.2-2016). The data identifier is followed by a character string. Both together have a maximum length according to the table below. If the information is shorter, spaces are added to it.

Following information is possible, positions 1 to 4 are always present, the other according to need of production:

Position	Type of information	Explanation	Data identifier	Number of digits incl. data identifier	Example
1	Beckhoff order number	Beckhoff order number	1P	8	1P 072222
2	Beckhoff Traceability Number (BTN)	Unique serial number, see note below	SBTN	12	S BTNk4p562d7
3	Article description	Beckhoff article description, e.g. EL1008	1K	32	1K EL1809
4	Quantity	Quantity in packaging unit, e.g. 1, 10, etc.	Q	6	Q 1
5	Batch number	Optional: Year and week of production	2P	14	2P 401503180016
6	ID/serial number	Optional: Present-day serial number system, e.g. with safety products	51S	12	51S 678294
7	Variant number	Optional: Product variant number on the basis of standard products	30P	32	30P F971, 2*K183
...					

Further types of information and data identifiers are used by Beckhoff and serve internal processes.

Structure of the BIC

Example of composite information from positions 1 to 4 and with the above given example value on position 6. The data identifiers are highlighted in bold font:

1P072222**S**BTNk4p562d7**1K**EL1809 **Q**1 **51S**678294

Accordingly as DMC:



Fig. 18: Example DMC **1P**072222**S**BTNk4p562d7**1K**EL1809 **Q**1 **51S**678294

BTN

An important component of the BIC is the Beckhoff Traceability Number (BTN, position 2). The BTN is a unique serial number consisting of eight characters that will replace all other serial number systems at Beckhoff in the long term (e.g. batch designations on IO components, previous serial number range for safety products, etc.). The BTN will also be introduced step by step, so it may happen that the BTN is not yet coded in the BIC.

NOTE

This information has been carefully prepared. However, the procedure described is constantly being further developed. We reserve the right to revise and change procedures and documentation at any time and without prior notice. No claims for changes can be made from the information, illustrations and descriptions in this information.

5.2 Support and Service

Beckhoff and their partners around the world offer comprehensive support and service, making available fast and competent assistance with all questions related to Beckhoff products and system solutions.

Beckhoff's branch offices and representatives

Please contact your Beckhoff branch office or representative for local support and service on Beckhoff products!

The addresses of Beckhoff's branch offices and representatives round the world can be found on her internet pages: <https://www.beckhoff.com>

You will also find further documentation for Beckhoff components there.

Beckhoff Support

Support offers you comprehensive technical assistance, helping you not only with the application of individual Beckhoff products, but also with other, wide-ranging services:

- support
- design, programming and commissioning of complex automation systems
- and extensive training program for Beckhoff system components

Hotline: +49 5246 963 157
Fax: +49 5246 963 9157
e-mail: support@beckhoff.com

Beckhoff Service

The Beckhoff Service Center supports you in all matters of after-sales service:

- on-site service
- repair service
- spare parts service
- hotline service

Hotline: +49 5246 963 460
Fax: +49 5246 963 479
e-mail: service@beckhoff.com

Beckhoff Headquarters

Beckhoff Automation GmbH & Co. KG

Huelshorstweg 20
33415 Verl
Germany

Phone: +49 5246 963 0
Fax: +49 5246 963 198
e-mail: info@beckhoff.com
web: <https://www.beckhoff.com>

Table of figures

Fig. 1	KL6771 - MP-bus master terminal	8
Fig. 2	Basic Function Principles	10
Fig. 3	MP-bus topologies	11
Fig. 4	Spring contacts of the Beckhoff I/O components	12
Fig. 5	Attaching on mounting rail.....	13
Fig. 6	Disassembling of terminal	14
Fig. 7	Power contact on left side	15
Fig. 8	Standard wiring	17
Fig. 9	Pluggable wiring.....	17
Fig. 10	High Density Terminals	18
Fig. 11	Connecting a cable on a terminal point.....	19
Fig. 12	Contact assignment	20
Fig. 13	Diagnostic LEDs.....	21
Fig. 14	Operation of MP-bus slaves (actuators) with DC power supply.....	22
Fig. 15	Operation of MP-bus slaves (actuators) with AC power supply	22
Fig. 16	MP-Bus length in relation to the effective power of all drives.....	23
Fig. 17	BIC as data matrix code (DMC, code scheme ECC200)	27
Fig. 18	Example DMC 1P072222SBTNk4p562d71KEL1809 Q1 51S678294	28

More Information:
www.beckhoff.com/KL6771

Beckhoff Automation GmbH & Co. KG
Hülshorstweg 20
33415 Verl
Germany
Phone: +49 5246 9630
info@beckhoff.com
www.beckhoff.com

