

Documentation | EN

# KL2784/KS2784, KL2794/KS2794

Four channel bus terminals with digital switching outputs, solid state

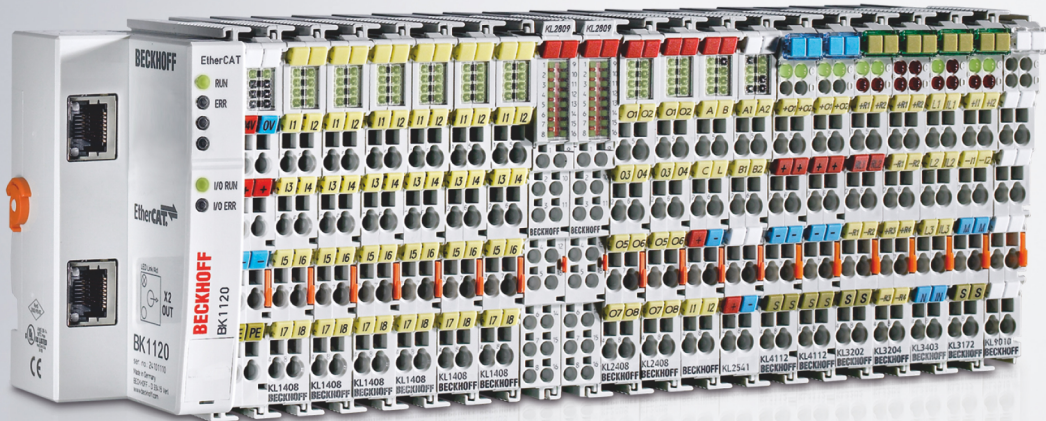



# Table of contents

<b>1 Foreword</b> .....	<b>5</b>
1.1 Notes on the documentation .....	5
1.2 Safety instructions .....	6
1.3 Documentation issue status .....	7
<b>2 Product overview</b> .....	<b>8</b>
2.1 KL2784 - Introduction .....	8
2.2 KL2794 - Introduction .....	9
2.3 Technical data .....	10
2.4 LED display .....	11
<b>3 Mounting and wiring</b> .....	<b>12</b>
3.1 Instructions for ESD protection .....	12
3.2 Installation on mounting rails .....	13
3.3 Connection .....	16
3.3.1 Connection system .....	16
3.3.2 Wiring .....	18
3.3.3 KL2784 - Connection .....	19
3.3.4 KL2794 - Connection .....	20
3.4 ATEX - Special conditions (standard temperature range) .....	21
3.5 Continuative documentation for ATEX and IECEx .....	22
<b>4 Appendix</b> .....	<b>23</b>
4.1 Support and Service .....	23



# 1 Foreword

## 1.1 Notes on the documentation

### Intended audience

This description is only intended for the use of trained specialists in control and automation engineering who are familiar with the applicable national standards.

It is essential that the documentation and the following notes and explanations are followed when installing and commissioning these components.

It is the duty of the technical personnel to use the documentation published at the respective time of each installation and commissioning.

The responsible staff must ensure that the application or use of the products described satisfy all the requirements for safety, including all the relevant laws, regulations, guidelines and standards.

### Disclaimer

The documentation has been prepared with care. The products described are, however, constantly under development.

We reserve the right to revise and change the documentation at any time and without prior announcement.

No claims for the modification of products that have already been supplied may be made on the basis of the data, diagrams and descriptions in this documentation.

### Trademarks

Beckhoff®, TwinCAT®, TwinCAT/BSD®, TC/BSD®, EtherCAT®, EtherCAT G®, EtherCAT G10®, EtherCAT P®, Safety over EtherCAT®, TwinSAFE®, XFC®, XTS® and XPlanar® are registered trademarks of and licensed by Beckhoff Automation GmbH. Other designations used in this publication may be trademarks whose use by third parties for their own purposes could violate the rights of the owners.

### Patent Pending

The EtherCAT Technology is covered, including but not limited to the following patent applications and patents: EP1590927, EP1789857, EP1456722, EP2137893, DE102015105702 with corresponding applications or registrations in various other countries.



EtherCAT® is registered trademark and patented technology, licensed by Beckhoff Automation GmbH, Germany.

### Copyright

© Beckhoff Automation GmbH & Co. KG, Germany.

The reproduction, distribution and utilization of this document as well as the communication of its contents to others without express authorization are prohibited.

Offenders will be held liable for the payment of damages. All rights reserved in the event of the grant of a patent, utility model or design.

## 1.2 Safety instructions

### Safety regulations

Please note the following safety instructions and explanations!  
Product-specific safety instructions can be found on following pages or in the areas mounting, wiring, commissioning etc.

### Exclusion of liability

All the components are supplied in particular hardware and software configurations appropriate for the application. Modifications to hardware or software configurations other than those described in the documentation are not permitted, and nullify the liability of Beckhoff Automation GmbH & Co. KG.

### Personnel qualification

This description is only intended for trained specialists in control, automation and drive engineering who are familiar with the applicable national standards.

### Description of instructions

In this documentation the following instructions are used.  
These instructions must be read carefully and followed without fail!

#### DANGER

##### Serious risk of injury!

Failure to follow this safety instruction directly endangers the life and health of persons.

#### WARNING

##### Risk of injury!

Failure to follow this safety instruction endangers the life and health of persons.

#### CAUTION

##### Personal injuries!

Failure to follow this safety instruction can lead to injuries to persons.

#### NOTE

##### Damage to environment/equipment or data loss

Failure to follow this instruction can lead to environmental damage, equipment damage or data loss.



##### Tip or pointer

This symbol indicates information that contributes to better understanding.

### 1.3 Documentation issue status

Version	Comment
2.1.0	<ul style="list-style-type: none"> <li>• Technical data updated</li> <li>• Chapter <i>Instructions for ESD protection</i> added</li> <li>• Design of the safety instructions adapted to IEC 82079-1</li> <li>• New title page</li> </ul>
2.0.0	<ul style="list-style-type: none"> <li>• Migration</li> </ul>
1.0.0	<ul style="list-style-type: none"> <li>• First release</li> </ul>

#### Hardware and firmware versions

Documentation version	KL2784/KS2784		KL2794/KS2794	
	Firmware	Hardware	Firmware	Hardware
2.1.0	-	03	-	03
2.0.0	-	02	-	02
1.0.0	-	02	-	02

The K-bus firmware and hardware version (delivery state) are indicated by the serial number printed at the side of the terminal.

#### Syntax of the serial number

Structure of the serial number: WW YY FF HH

WW - week of production (calendar week)

YY - year of production

FF - K-bus firmware version

HH - hardware version

Example with serial number 49 08 1B 03:

49 - week of production 49

08 - year of production 2008

1B - firmware version 1B

03 - hardware version 03

## 2 Product overview

### 2.1 KL2784 - Introduction

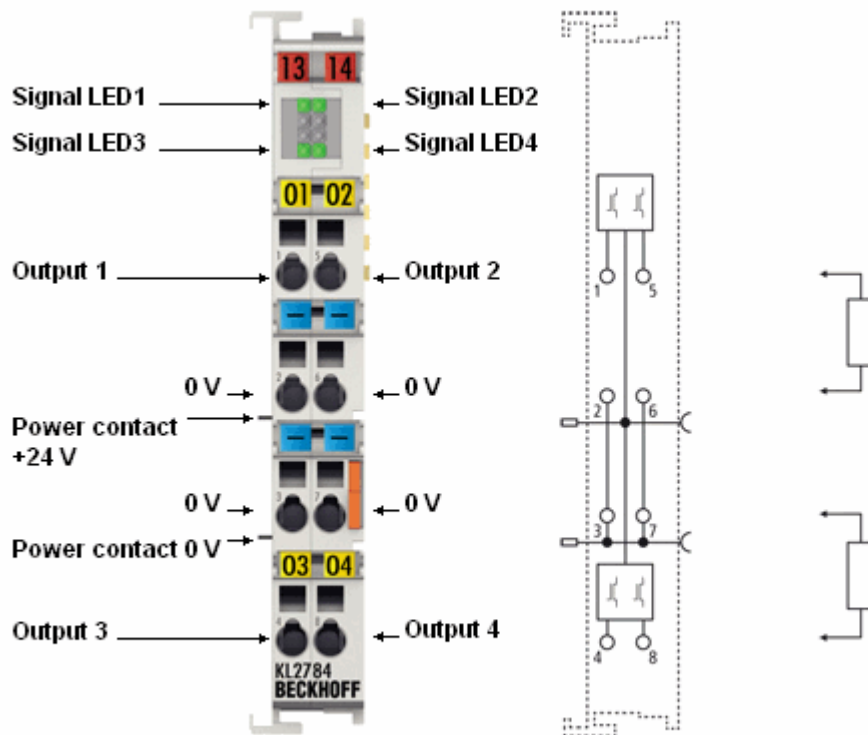

KL2784 - Bus terminal, 4-channel solid state output, 30 V<sub>AC</sub>, 48 V<sub>DC</sub>, 2 A

The KL2784 digital output terminal is able to switch voltages up to 30 V<sub>AC</sub>, 48 V<sub>DC</sub> using advanced MOSFET transistors. The semiconductor switches connected to the power contacts represent a substitute for relay contacts. They are short-circuit proof and free from wear, thereby increasing the availability of the application. The output is short-circuit-proof to a limited extent. The output transistor can cope with short-term overcurrents until the fuse is triggered. The Bus Terminal contains four channels that indicate its signal state by means of light emitting diodes.



## 2.2 KL2794 - Introduction

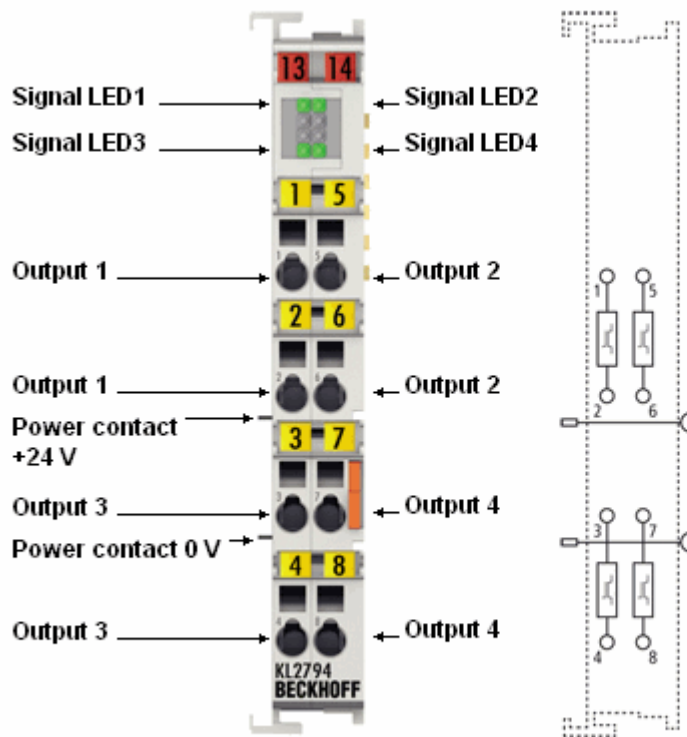

Fig. 1: KL2794 - Bus terminal, 4-channel solid state output, 30 V<sub>AC</sub>, 48 V<sub>DC</sub>, 2 A, potential-free

The KL2794 digital output terminal is able to switch voltages up to 30 V<sub>AC</sub>, 48 V<sub>DC</sub> using advanced MOSFET transistors. The four potential-free semiconductor switches represent a substitute for relay contacts. They are short-circuit proof and free from wear, thereby increasing the availability of the application. The output is short-circuit-proof to a limited extent. The output transistor can cope with short-term overcurrents until the fuse is triggered. The Bus Terminal has four channels, whose signal state is displayed by LEDs.

## 2.3 Technical data

Technical data	KL2784/KS2784	KL2794/KS2794
Number of outputs	4 make contacts	
Rated load voltage	0 ... 30 V <sub>AC/DC</sub> (pure ohmic load 0 ... 48 V <sub>DC</sub> )	
Output current	2 A per channel	
Breakdown voltage	80 V	
Peak current	5 A (100 ms), < 50 A (10 ms)	
Short circuit current	not short-circuit proof, see peak current	
Switching on speed	typical 1.8 ms, max. 5 ms	
Switching off speed	typical 30 ms, max. 50 ms	
On-resistance	typical 0.03 Ω	
Isolation voltage	-	< 200 V (channel/channel)
Electrical isolation	500 V (K-bus/mains voltage)	
Special features	alternative for relay contacts	alternative for relay contacts, potential-free
Power supply for the electronics	via the K-bus and through the power contacts	
Current consumption from K-bus	typically: 80 mA	
Bit width in the output process image	4 bit	
Configuration	via the Bus Coupler or the controller	
Weight	app. 50 g	
Permissible ambient temperature range during operation	0°C ... +55°C	
Permissible ambient temperature range during storage	-25°C ... +85°C	
Permissible relative air humidity	95%, no condensation	
Dimensions (W x H x D)	app. 15 mm x 100 mm x 70 mm (aligned width: 12 mm)	
Mounting [ <a href="#">▶ 13</a> ]	on 35 mm mounting rail conforms to EN 60715	
Vibration / shock resistance	conforms to EN 60068-2-6 / EN 60068-2-27	
EMC immunity / emission	conforms to EN 61000-6-2 / EN 61000-6-4	
Protection class	IP20	
Pluggable wiring	for all KSxxxx terminals	
Correct installation position	variable	
Approvals / markings	CE, <a href="#">cULus</a> [ <a href="#">▶ 21</a> ], ATEX	

### Ex marking

Standard	Marking
ATEX	II 3 G Ex nA IIC T4 Gc

## 2.4 LED display

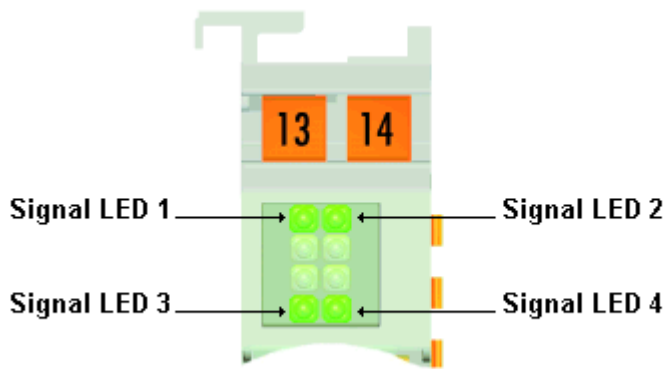

Fig. 2: LED display

LED	Display	
Signal LED 1	off	Output 1 switched off
	on	Output 1 switched on
Signal LED 2	off	Output 2 switched off
	on	Output 2 switched on
Signal LED 3	off	Output 3 switched off
	on	Output 3 switched on
Signal LED 4	off	Output 4 switched off
	on	Output 4 switched on

## 3 Mounting and wiring

### 3.1 Instructions for ESD protection

#### NOTE

##### **Destruction of the devices by electrostatic discharge possible!**

The devices contain components at risk from electrostatic discharge caused by improper handling.

- Please ensure you are electrostatically discharged and avoid touching the contacts of the device directly.
- Avoid contact with highly insulating materials (synthetic fibers, plastic film etc.).
- Surroundings (working place, packaging and personnel) should be grounded probably, when handling with the devices.
- Each assembly must be terminated at the right hand end with a KL9010 bus end terminal, to ensure the protection class and ESD protection.

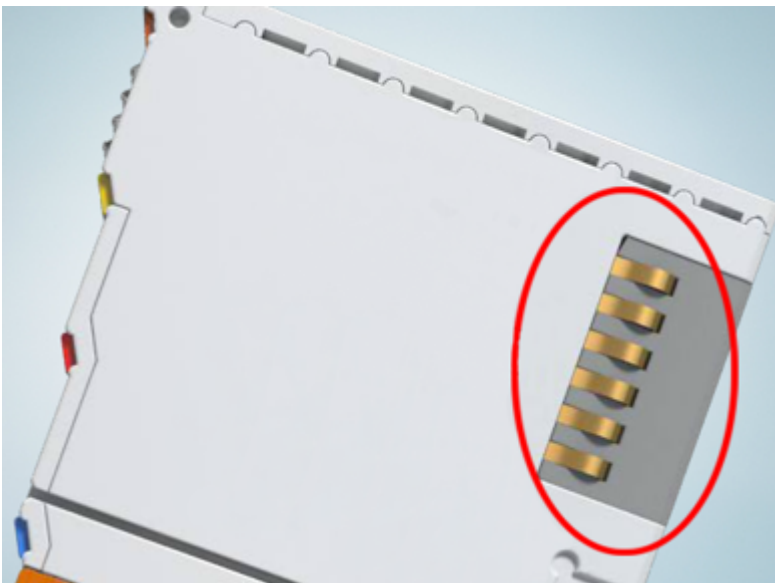

Fig. 3: Spring contacts of the Beckhoff I/O components

## 3.2 Installation on mounting rails

### ⚠ WARNING

#### Risk of electric shock and damage of device!

Bring the bus terminal system into a safe, powered down state before starting installation, disassembly or wiring of the bus terminals!

#### Assembly

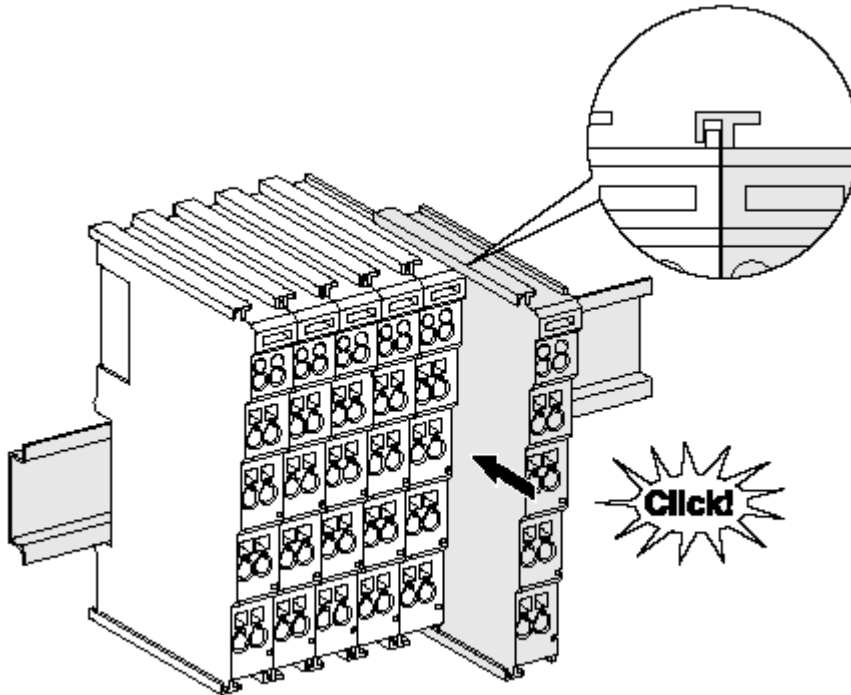

Fig. 4: Attaching on mounting rail

The bus coupler and bus terminals are attached to commercially available 35 mm mounting rails (DIN rails according to EN 60715) by applying slight pressure:

1. First attach the fieldbus coupler to the mounting rail.
2. The bus terminals are now attached on the right-hand side of the fieldbus coupler. Join the components with tongue and groove and push the terminals against the mounting rail, until the lock clicks onto the mounting rail.

If the terminals are clipped onto the mounting rail first and then pushed together without tongue and groove, the connection will not be operational! When correctly assembled, no significant gap should be visible between the housings.

#### **i** Fixing of mounting rails

The locking mechanism of the terminals and couplers extends to the profile of the mounting rail. At the installation, the locking mechanism of the components must not come into conflict with the fixing bolts of the mounting rail. To mount the mounting rails with a height of 7.5 mm under the terminals and couplers, you should use flat mounting connections (e.g. countersunk screws or blind rivets).

## Disassembly

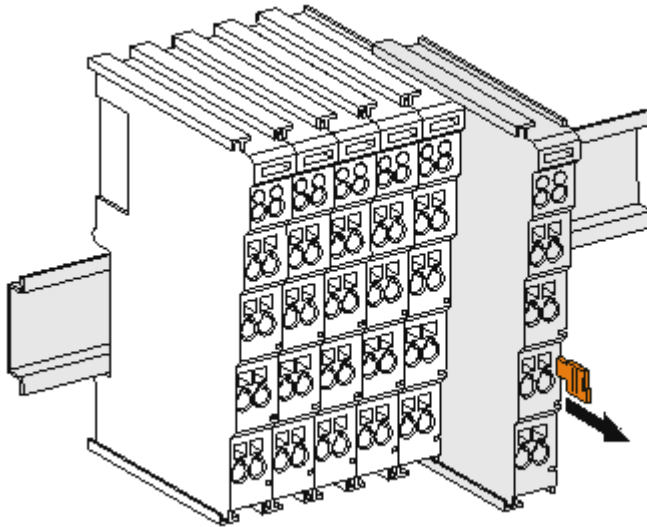

Fig. 5: Disassembling of terminal

Each terminal is secured by a lock on the mounting rail, which must be released for disassembly:

1. Pull the terminal by its orange-colored lugs approximately 1 cm away from the mounting rail. In doing so for this terminal the mounting rail lock is released automatically and you can pull the terminal out of the bus terminal block easily without excessive force.
2. Grasp the released terminal with thumb and index finger simultaneous at the upper and lower grooved housing surfaces and pull the terminal out of the bus terminal block.

## Connections within a bus terminal block

The electric connections between the Bus Coupler and the Bus Terminals are automatically realized by joining the components:

- The six spring contacts of the K-Bus/E-Bus deal with the transfer of the data and the supply of the Bus Terminal electronics.
- The power contacts deal with the supply for the field electronics and thus represent a supply rail within the bus terminal block. The power contacts are supplied via terminals on the Bus Coupler (up to 24 V) or for higher voltages via power feed terminals.

### **i** Power Contacts

During the design of a bus terminal block, the pin assignment of the individual Bus Terminals must be taken account of, since some types (e.g. analog Bus Terminals or digital 4-channel Bus Terminals) do not or not fully loop through the power contacts. Power Feed Terminals (KL91xx, KL92xx or EL91xx, EL92xx) interrupt the power contacts and thus represent the start of a new supply rail.

## PE power contact

The power contact labeled PE can be used as a protective earth. For safety reasons this contact mates first when plugging together, and can ground short-circuit currents of up to 125 A.

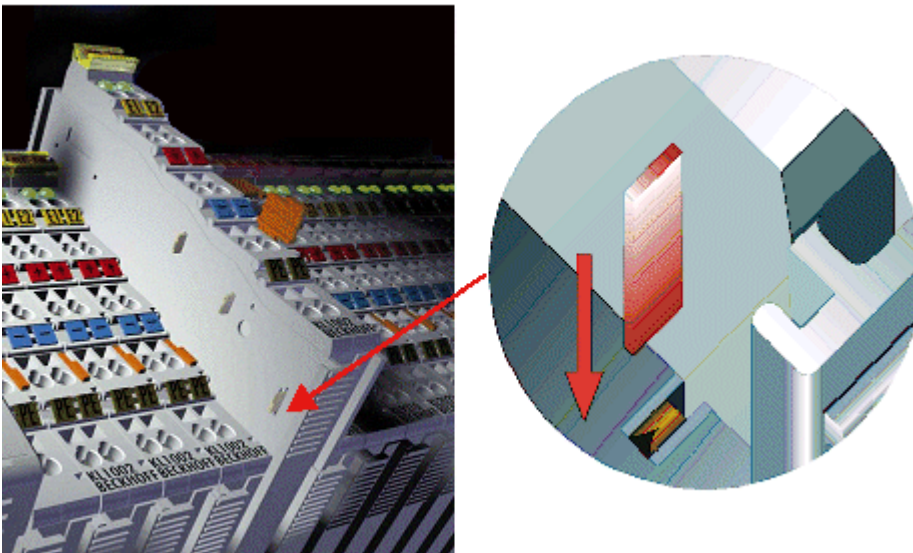

Fig. 6: Power contact on left side

### NOTE

#### Possible damage of the device

Note that, for reasons of electromagnetic compatibility, the PE contacts are capacitatively coupled to the mounting rail. This may lead to incorrect results during insulation testing or to damage on the terminal (e.g. disruptive discharge to the PE line during insulation testing of a consumer with a nominal voltage of 230 V). For insulation testing, disconnect the PE supply line at the Bus Coupler or the Power Feed Terminal! In order to decouple further feed points for testing, these Power Feed Terminals can be released and pulled at least 10 mm from the group of terminals.

### ⚠ WARNING

#### Risk of electric shock!

The PE power contact must not be used for other potentials!

## 3.3 Connection

### 3.3.1 Connection system

#### ⚠ WARNING

##### Risk of electric shock and damage of device!

Bring the bus terminal system into a safe, powered down state before starting installation, disassembly or wiring of the bus terminals!

#### Overview

The bus terminal system offers different connection options for optimum adaptation to the respective application:

- The terminals of ELxxxx and KLxxxx series with standard wiring include electronics and connection level in a single enclosure.
- The terminals of ESxxxx and KSxxxx series feature a pluggable connection level and enable steady wiring while replacing.
- The High Density Terminals (HD Terminals) include electronics and connection level in a single enclosure and have advanced packaging density.

#### Standard wiring (ELxxxx / KLxxxx)



Fig. 7: Standard wiring

The terminals of ELxxxx and KLxxxx series have been tried and tested for years. They feature integrated screwless spring force technology for fast and simple assembly.

#### Pluggable wiring (ESxxxx / KSxxxx)



Fig. 8: Pluggable wiring

The terminals of ESxxxx and KSxxxx series feature a pluggable connection level. The assembly and wiring procedure is the same as for the ELxxxx and KLxxxx series. The pluggable connection level enables the complete wiring to be removed as a plug connector from the top of the housing for servicing. The lower section can be removed from the terminal block by pulling the unlocking tab. Insert the new component and plug in the connector with the wiring. This reduces the installation time and eliminates the risk of wires being mixed up.

The familiar dimensions of the terminal only had to be changed slightly. The new connector adds about 3 mm. The maximum height of the terminal remains unchanged.



A tab for strain relief of the cable simplifies assembly in many applications and prevents tangling of individual connection wires when the connector is removed.

Conductor cross sections between 0.08 mm<sup>2</sup> and 2.5 mm<sup>2</sup> can continue to be used with the proven spring force technology.

The overview and nomenclature of the product names for ESxxxx and KSxxxx series has been retained as known from ELxxxx and KLxxxx series.

### High Density Terminals (HD Terminals)



Fig. 9: High Density Terminals

The terminals from these series with 16 terminal points are distinguished by a particularly compact design, as the packaging density is twice as large as that of the standard 12 mm bus terminals. Massive conductors and conductors with a wire end sleeve can be inserted directly into the spring loaded terminal point without tools.

---

#### ● Wiring HD Terminals



The High Density Terminals of the ELx8xx and KLx8xx series doesn't support pluggable wiring.

---

### Ultrasonically “bonded” (ultrasonically welded) conductors

---

#### ● Ultrasonically “bonded” conductors



It is also possible to connect the Standard and High Density Terminals with ultrasonically “bonded” (ultrasonically welded) conductors. In this case, please note the tables concerning the wire-size width!

---

### 3.3.2 Wiring

#### ⚠ WARNING

#### Risk of electric shock and damage of device!

Bring the bus terminal system into a safe, powered down state before starting installation, disassembly or wiring of the bus terminals!

#### Terminals for standard wiring ELxxxx/KLxxxx and for pluggable wiring ESxxxx/KSxxxx

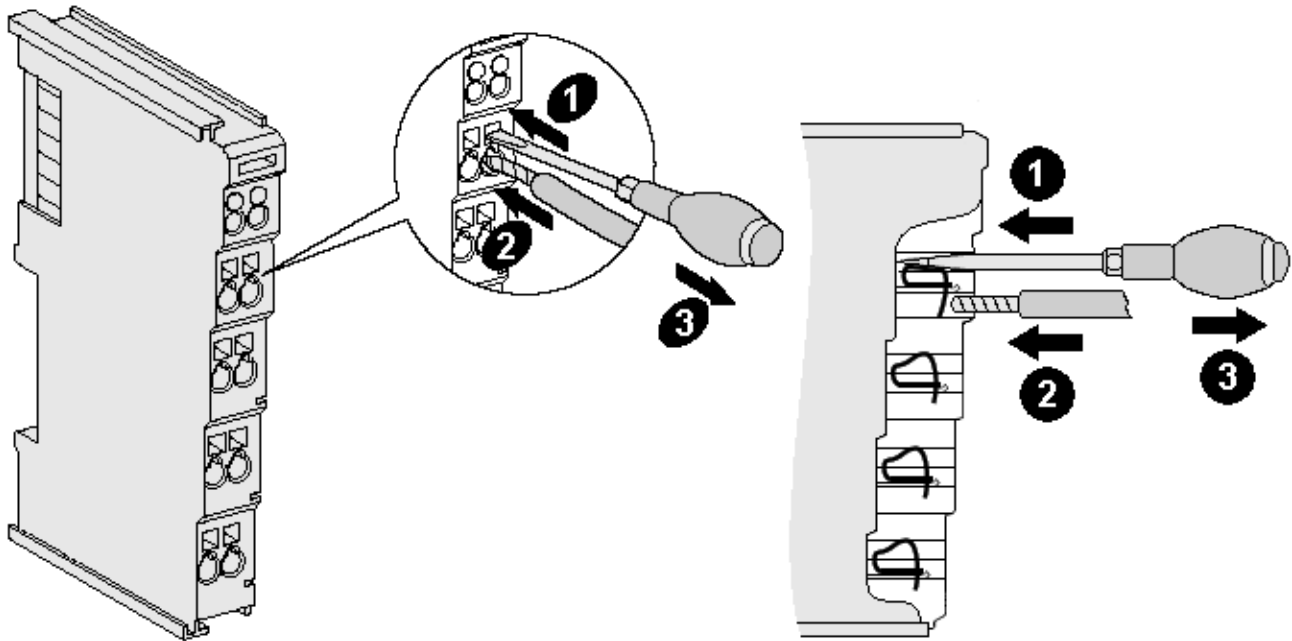

Fig. 10: Connecting a cable on a terminal point

Up to eight terminal points enable the connection of solid or finely stranded cables to the bus terminal. The terminal points are implemented in spring force technology. Connect the cables as follows:

1. Open a terminal point by pushing a screwdriver straight against the stop into the square opening above the terminal point. Do not turn the screwdriver or move it alternately (don't toggle).
2. The wire can now be inserted into the round terminal opening without any force.
3. The terminal point closes automatically when the pressure is released, holding the wire securely and permanently.

See the following table for the suitable wire size width.

Terminal housing	ELxxxx, KLxxxx	ESxxxx, KSxxxx
Wire size width (single core wires)	0.08 ... 2.5 mm <sup>2</sup>	0.08 ... 2.5 mm <sup>2</sup>
Wire size width (fine-wire conductors)	0.08 ... 2.5 mm <sup>2</sup>	0,08 ... 2.5 mm <sup>2</sup>
Wire size width (conductors with a wire end sleeve)	0.14 ... 1.5 mm <sup>2</sup>	0.14 ... 1.5 mm <sup>2</sup>
Wire stripping length	8 ... 9 mm	9 ... 10 mm

#### High Density Terminals (HD Terminals [[▶ 17](#)]) with 16 terminal points

The conductors of the HD Terminals are connected without tools for single-wire conductors using the direct plug-in technique, i.e. after stripping the wire is simply plugged into the terminal point. The cables are released, as usual, using the contact release with the aid of a screwdriver. See the following table for the suitable wire size width.

<b>Terminal housing</b>	<b>High Density Housing</b>
<b>Wire size width (single core wires)</b>	0.08 ... 1.5 mm <sup>2</sup>
<b>Wire size width (fine-wire conductors)</b>	0.25 ... 1.5 mm <sup>2</sup>
<b>Wire size width (conductors with a wire end sleeve)</b>	0.14 ... 0.75 mm <sup>2</sup>
<b>Wire size width (ultrasonically "bonded" conductors)</b>	only 1.5 mm <sup>2</sup>
<b>Wire stripping length</b>	8 ... 9 mm

### 3.3.3 KL2784 - Connection

**⚠ WARNING**

**Risk of injury through electric shock and damage to the device!**

Bring the Bus Terminals system into a safe, de-energized state before starting mounting, disassembly or wiring of the Bus Terminals!

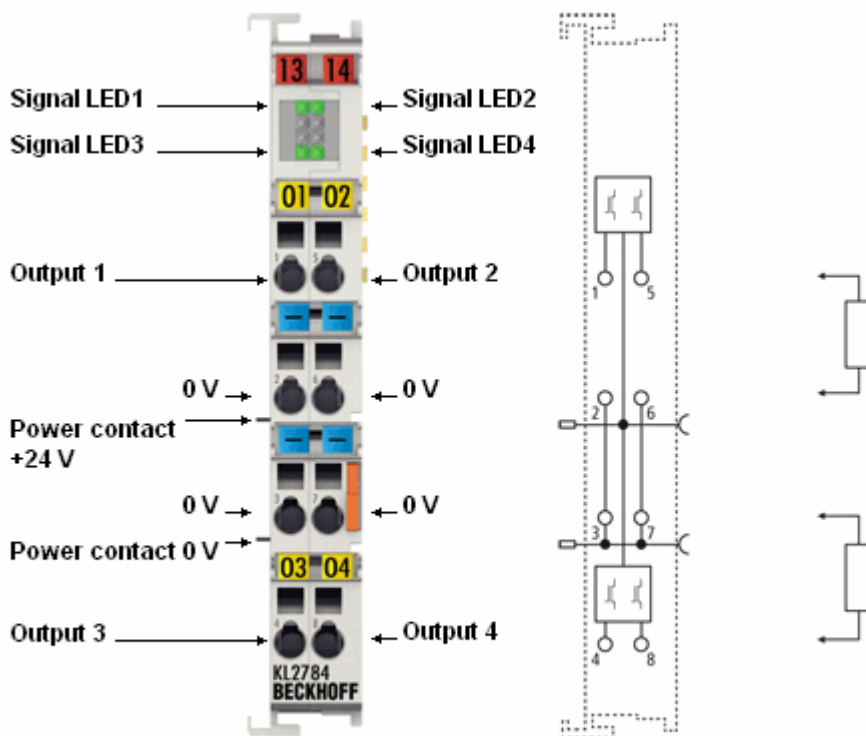

Fig. 11: KL2784 - Connection

Terminal point	No.:	Connection for
Output 1	1	Load 1
0 V	2	0 V (internally connected to terminal points 3, 6, 7 and power contact for 0 V)
0 V	3	0 V (internally connected to terminal points 2, 6, 7 and power contact for 0 V)
Output 3	4	Load 3
Output 2	5	Load 2
0 V	6	0 V (internally connected to terminal points 2, 3, 7 and power contact for 0 V)
0 V	7	0 V (internally connected to terminal points 2, 3, 6 and power contact for 0 V)
Output 4	8	Load 4

### 3.3.4 KL2794 - Connection

**⚠ WARNING**

**Risk of injury through electric shock and damage to the device!**

Bring the Bus Terminals system into a safe, de-energized state before starting mounting, disassembly or wiring of the Bus Terminals!

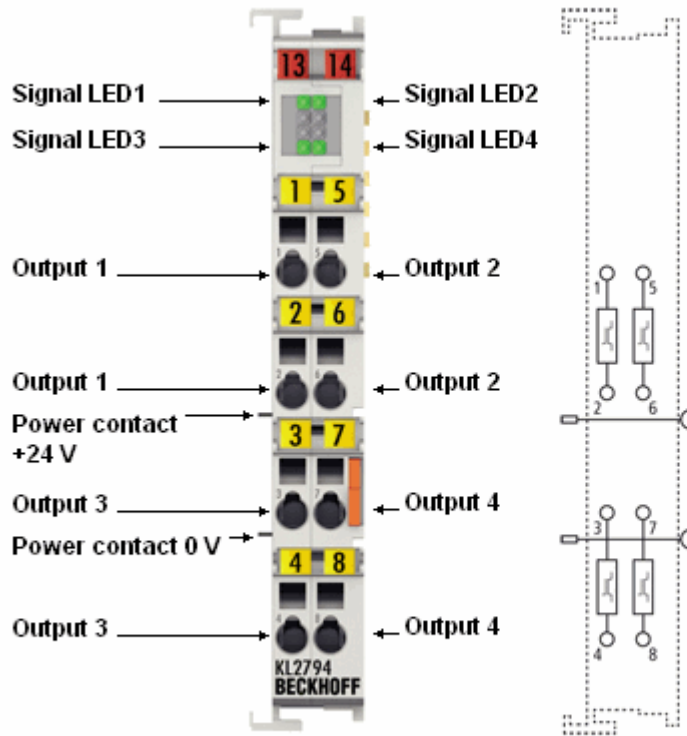

Fig. 12: KL2794 - Connection

Terminal point	No.:	Connection for
Output 1	1	Output 1: Potential-free contact
Output 1	2	Output 1: Potential-free contact
Output 3	3	Output 3: Potential-free contact
Output 3	4	Output 3: Potential-free contact
Output 2	5	Output 2: Potential-free contact
Output 2	6	Output 2: Potential-free contact
Output 4	7	Output 4: Potential-free contact
Output 4	8	Output 4: Potential-free contact

### 3.4 ATEX - Special conditions (standard temperature range)

**⚠ WARNING**

**Observe the special conditions for the intended use of Beckhoff fieldbus components with standard temperature range in potentially explosive areas (directive 2014/34/EU)!**

- The certified components are to be installed in a suitable housing that guarantees a protection class of at least IP54 in accordance with EN 60079-15! The environmental conditions during use are thereby to be taken into account!
- For dust (only the fieldbus components of certificate no. KEMA 10ATEX0075 X Issue 9): The equipment shall be installed in a suitable enclosure providing a degree of protection of IP54 according to EN 60079-31 for group IIIA or IIIB and IP6X for group IIIC, taking into account the environmental conditions under which the equipment is used!
- If the temperatures during rated operation are higher than 70°C at the feed-in points of cables, lines or pipes, or higher than 80°C at the wire branching points, then cables must be selected whose temperature data correspond to the actual measured temperature values!
- Observe the permissible ambient temperature range of 0 to 55°C for the use of Beckhoff fieldbus components standard temperature range in potentially explosive areas!
- Measures must be taken to protect against the rated operating voltage being exceeded by more than 40% due to short-term interference voltages!
- The individual terminals may only be unplugged or removed from the Bus Terminal system if the supply voltage has been switched off or if a non-explosive atmosphere is ensured!
- The connections of the certified components may only be connected or disconnected if the supply voltage has been switched off or if a non-explosive atmosphere is ensured!
- The fuses of the KL92xx/EL92xx power feed terminals may only be exchanged if the supply voltage has been switched off or if a non-explosive atmosphere is ensured!
- Address selectors and ID switches may only be adjusted if the supply voltage has been switched off or if a non-explosive atmosphere is ensured!

**Standards**

The fundamental health and safety requirements are fulfilled by compliance with the following standards:

- EN 60079-0:2012+A11:2013
- EN 60079-15:2010
- EN 60079-31:2013 (only for certificate no. KEMA 10ATEX0075 X Issue 9)

**Marking**

The Beckhoff fieldbus components with standard temperature range certified according to the ATEX directive for potentially explosive areas bear one of the following markings:



**II 3G KEMA 10ATEX0075 X Ex nA IIC T4 Gc Ta: 0 ... +55°C**  
 II 3D KEMA 10ATEX0075 X Ex tc IIIC T135°C Dc Ta: 0 ... +55°C  
 (only for fieldbus components of certificate no. KEMA 10ATEX0075 X Issue 9)

or



**II 3G KEMA 10ATEX0075 X Ex nA nC IIC T4 Gc Ta: 0 ... +55°C**  
 II 3D KEMA 10ATEX0075 X Ex tc IIIC T135°C Dc Ta: 0 ... +55°C  
 (only for fieldbus components of certificate no. KEMA 10ATEX0075 X Issue 9)

## 3.5 Continulative documentation for ATEX and IECEx

---



### Continulative documentation about explosion protection according to ATEX and IECEx

Pay also attention to the continuative documentation

#### **Ex. Protection for Terminal Systems**

Notes on the use of the Beckhoff terminal systems in hazardous areas according to ATEX and IECEx

that is available for [download](#) on the Beckhoff homepage [www.beckhoff.com](http://www.beckhoff.com)!

---

## 4 Appendix

### 4.1 Support and Service

Beckhoff and their partners around the world offer comprehensive support and service, making available fast and competent assistance with all questions related to Beckhoff products and system solutions.

#### Beckhoff's branch offices and representatives

Please contact your Beckhoff branch office or representative for local support and service on Beckhoff products!

The addresses of Beckhoff's branch offices and representatives round the world can be found on her internet pages: <https://www.beckhoff.com>

You will also find further documentation for Beckhoff components there.

#### Beckhoff Support

Support offers you comprehensive technical assistance, helping you not only with the application of individual Beckhoff products, but also with other, wide-ranging services:

- support
- design, programming and commissioning of complex automation systems
- and extensive training program for Beckhoff system components

Hotline: +49 5246 963 157  
Fax: +49 5246 963 9157  
e-mail: [support@beckhoff.com](mailto:support@beckhoff.com)

#### Beckhoff Service

The Beckhoff Service Center supports you in all matters of after-sales service:

- on-site service
- repair service
- spare parts service
- hotline service

Hotline: +49 5246 963 460  
Fax: +49 5246 963 479  
e-mail: [service@beckhoff.com](mailto:service@beckhoff.com)

#### Beckhoff Headquarters

Beckhoff Automation GmbH & Co. KG

Huelshorstweg 20  
33415 Verl  
Germany

Phone: +49 5246 963 0  
Fax: +49 5246 963 198  
e-mail: [info@beckhoff.com](mailto:info@beckhoff.com)  
web: <https://www.beckhoff.com>

## Table of figures

Fig. 1	KL2794 - Bus terminal, 4-channel solid state output, 30 VAC, 48 VDC, 2 A, potential-free.....	9
Fig. 2	LED display.....	11
Fig. 3	Spring contacts of the Beckhoff I/O components.....	12
Fig. 4	Attaching on mounting rail .....	13
Fig. 5	Disassembling of terminal.....	14
Fig. 6	Power contact on left side.....	15
Fig. 7	Standard wiring.....	16
Fig. 8	Pluggable wiring .....	16
Fig. 9	High Density Terminals.....	17
Fig. 10	Connecting a cable on a terminal point .....	18
Fig. 11	KL2784 - Connection .....	19
Fig. 12	KL2794 - Connection .....	20





More Information:  
[www.beckhoff.com/KL2xxx](http://www.beckhoff.com/KL2xxx)

Beckhoff Automation GmbH & Co. KG  
Hülshorstweg 20  
33415 Verl  
Germany  
Phone: +49 5246 9630  
[info@beckhoff.com](mailto:info@beckhoff.com)  
[www.beckhoff.com](http://www.beckhoff.com)

