

Table of contents

1 Foreword	5
1.1 Notes on the documentation.....	5
1.2 Safety instructions	6
1.3 Documentation issue status	7
2 Product overview	8
2.1 KL/KS1702, KL/KS1712 - Introduction	8
2.1.1 Technical data	9
2.1.2 Contact assignment and LEDs	10
2.2 KL/KS1704 - Introduction	11
2.2.1 Technical data	12
2.2.2 Contact assignment and LEDs	13
2.3 KL/KS1722 - Introduction	14
2.3.1 Technical data	15
2.3.2 Contact assignment and LEDs	16
3 Mounting and wiring	17
3.1 Instructions for ESD protection.....	17
3.2 Installation on mounting rails	18
3.3 Installation instructions for enhanced mechanical load capacity	21
3.4 Connection	22
3.4.1 Connection system	22
3.4.2 Wiring.....	24
3.4.3 Shielding	25
3.5 ATEX - Special conditions (standard temperature range)	26
3.6 Continulative documentation for ATEX and IECEx	27
3.7 Disposal.....	27
4 TwinCAT	28
4.1 Programming	30
5 Appendix	31
5.1 Support and Service	31

1 Foreword

1.1 Notes on the documentation

Intended audience

This description is only intended for the use of trained specialists in control and automation engineering who are familiar with the applicable national standards.

It is essential that the documentation and the following notes and explanations are followed when installing and commissioning these components.

It is the duty of the technical personnel to use the documentation published at the respective time of each installation and commissioning.

The responsible staff must ensure that the application or use of the products described satisfy all the requirements for safety, including all the relevant laws, regulations, guidelines and standards.

Disclaimer

The documentation has been prepared with care. The products described are, however, constantly under development.

We reserve the right to revise and change the documentation at any time and without prior announcement.

No claims for the modification of products that have already been supplied may be made on the basis of the data, diagrams and descriptions in this documentation.

Trademarks

Beckhoff®, TwinCAT®, TwinCAT/BSD®, TC/BSD®, EtherCAT®, EtherCAT G®, EtherCAT G10®, EtherCAT P®, Safety over EtherCAT®, TwinSAFE®, XFC®, XTS® and XPlanar® are registered trademarks of and licensed by Beckhoff Automation GmbH. Other designations used in this publication may be trademarks whose use by third parties for their own purposes could violate the rights of the owners.

Patent Pending

The EtherCAT Technology is covered, including but not limited to the following patent applications and patents: EP1590927, EP1789857, EP1456722, EP2137893, DE102015105702 with corresponding applications or registrations in various other countries.

The logo for EtherCAT, featuring the word "EtherCAT" in a bold, black, sans-serif font. A red arrow points from the top of the "A" towards the right, ending above the "T". A registered trademark symbol (®) is located to the right of the "T".

EtherCAT® is registered trademark and patented technology, licensed by Beckhoff Automation GmbH, Germany.

Copyright

© Beckhoff Automation GmbH & Co. KG, Germany.

The reproduction, distribution and utilization of this document as well as the communication of its contents to others without express authorization are prohibited.

Offenders will be held liable for the payment of damages. All rights reserved in the event of the grant of a patent, utility model or design.

1.2 Safety instructions

Safety regulations

Please note the following safety instructions and explanations!
Product-specific safety instructions can be found on following pages or in the areas mounting, wiring, commissioning etc.

Exclusion of liability

All the components are supplied in particular hardware and software configurations appropriate for the application. Modifications to hardware or software configurations other than those described in the documentation are not permitted, and nullify the liability of Beckhoff Automation GmbH & Co. KG.

Personnel qualification

This description is only intended for trained specialists in control, automation and drive engineering who are familiar with the applicable national standards.

Description of instructions

In this documentation the following instructions are used.
These instructions must be read carefully and followed without fail!

DANGER

Serious risk of injury!

Failure to follow this safety instruction directly endangers the life and health of persons.

WARNING

Risk of injury!

Failure to follow this safety instruction endangers the life and health of persons.

CAUTION

Personal injuries!

Failure to follow this safety instruction can lead to injuries to persons.

NOTE

Damage to environment/equipment or data loss

Failure to follow this instruction can lead to environmental damage, equipment damage or data loss.



Tip or pointer

This symbol indicates information that contributes to better understanding.

1.3 Documentation issue status

Version	Comment
4.1.0	<ul style="list-style-type: none"> • Product overview extended • Technical data updated • Ex markings added to technical data • Instructions for ESD protection added • Chapter <i>Disposal</i> added • New title page
4.0.0	<ul style="list-style-type: none"> • Migration • Document structure updated • Technical data updated • Installation instructions for enhanced mechanical load capacity added

Firmware and hardware versions

Documentation Version	KL/KS1702-0000		KL/KS1704-0000		KL/KS1722-0000	
	Firmware	Hardware	Firmware	Hardware	Firmware	Hardware
4.1.0	-	15	-	03	-	07
4.0.0	-	14	-	02	-	06

Documentation Version	KL/KS1712-0000		KL/KS1712-0010		KL/KS1712-0060	
	Firmware	Hardware	Firmware	Hardware	Firmware	Hardware
4.1.0	-	04	-	02	-	03
4.0.0	-	03	-	02	-	03

The K-bus firmware and hardware version (delivery state) are indicated by the serial number printed at the side of the terminal.

Syntax of the serial number

Structure of the serial number: WW YY FF HH

WW - week of production (calendar week)

YY - year of production

FF - K-bus firmware version

HH - hardware version

Example with serial number 49 05 1B 03

49 - week of production 49

05 - year of production 2005

1B - firmware version 1B

03 - hardware version 03

2 Product overview

Digital input terminals

Terminal	Number of inputs	Nominal voltage	Filter	Comment
KL/KS1702 [▶ 8]	2	120 V _{AC} / 230 V _{AC}	10 ms	
KL/KS1704 [▶ 11]	4	120 V _{AC} / 230 V _{AC}	10 ms	
KL/KS1712-0000 [▶ 8]	2	120 V _{AC/DC}	10 ms	
KL/KS1712-0010 [▶ 8]	2	24 V _{AC/DC}	10 ms	
KL/KS1712-0060 [▶ 8]	2	60 V _{DC}	10 ms	
KL/KS1722 [▶ 14]	2	120 V _{AC} / 230 V _{AC}	10 ms	

2.1 KL/KS1702, KL/KS1712 - Introduction

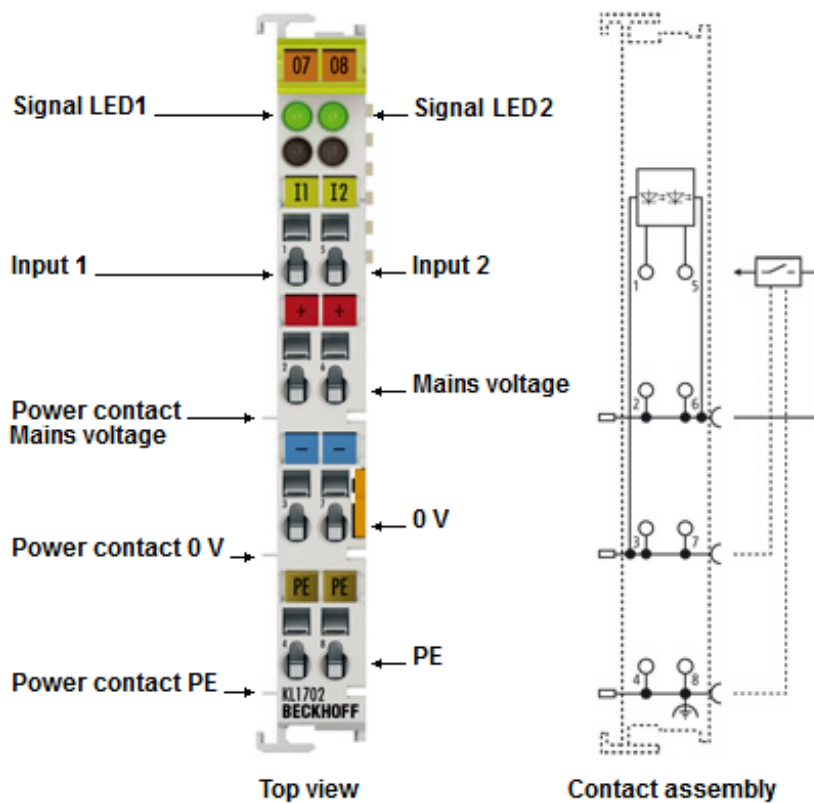

Fig. 1: KL1702

Two-channel digital input terminals for mains voltages from 24 V to 230 V

The KL/KS1702 und KL/KS1712-00x0 digital input terminals acquire the control signals from the process level and transmit them, in an electrically isolated form, to the higher-level automation unit. The direct connection of AC or DC sensors is possible. The Bus Terminals each contain two channels, whose signal states are displayed by LEDs.

2.1.1 Technical data

Technical data	KL1702-0000, KS1702-0000	KL1712-0000, KS1712-0000	KL1712-0010, KS1712-0010	KL1712-0060, KS1712-0060
Number of inputs	2			
Connection technology	4-wire			
Nominal voltage	120 V _{AC} /230 V _{AC}	120 V _{AC/DC}	24 V _{AC/DC}	60 V _{DC}
Signal voltage "0"	0 V ... 40 V		0 V ... 5 V	0 V ... 20 V
Signal voltage "1"	79 V ... 260 V	80 V ... 140 V	14 V ... 28.8 V	40 V ... 70 V
Input filter	typ. 10 ms			
Current consumption via K-bus	typ. 3 mA			
Switching times	10 ms			
Input current	> 3 mA, typ. 6 mA			
Electrical isolation	500 V (K-bus / field voltage)			
Bit width in process image	2 input bits			
Configuration	no address or configuration settings required			
Use for	230 V mains	120 V mains	24 V mains	Railway mains
Dimensions (W x H x D)	15 mm x 100 mm x 70 mm (aligned width 12 mm)			
Weight	app. 60 g			
Permissible ambient temperature during operation	0 °C to +55 °C			
Permissible ambient temperature during storage	-25 °C to +70 °C			
Permissible relative air humidity	5 % ... 95 %, no condensation			
Vibration / shock resistance	according to EN 60068-2-6 / EN60068-2-27, EN 60068-2-29			
EMC immunity / emission	conforms to EN 61000-6-2 / EN 61000-6-4			
Installation position	Variable			
Pluggable wiring	for all KSxxxx terminals			
Protection class	IP20			
Approvals/markings	CE, UKCA, cULus, EAC, GL, ATEX [▶ 26]	CE, UKCA, cULus, EAC, ATEX [▶ 26]		CE, UKCA, cULus, EAC

Ex marking

Standard	Marking
ATEX	II 3 G Ex nA IIC T4 Gc

2.1.2 Contact assignment and LEDs

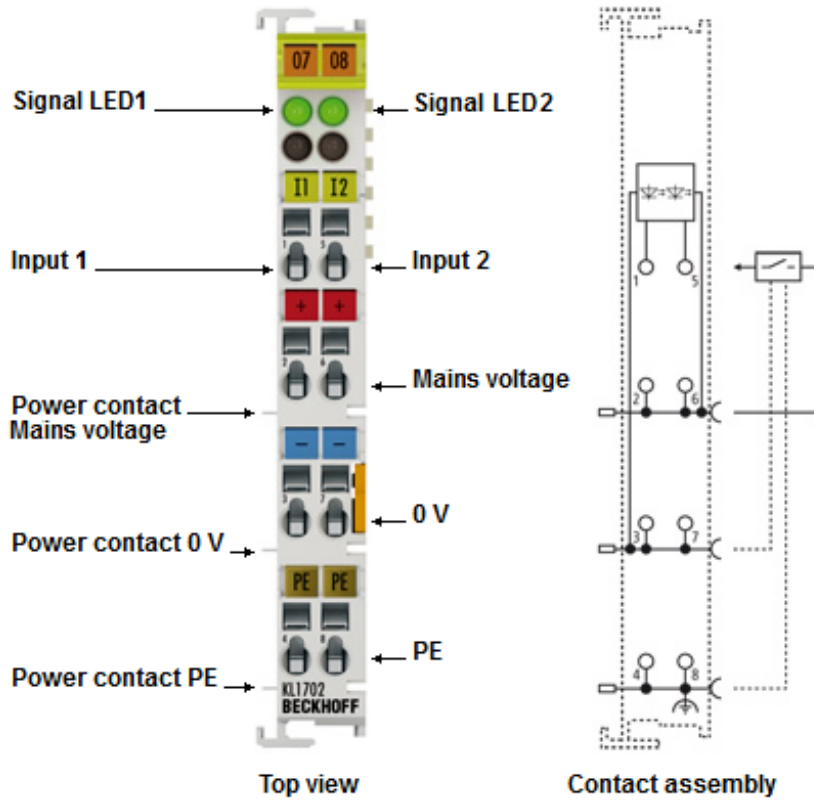

Fig. 2: KL1702 - Contact assignment and LEDs

KL1702/KS1702, KL1712/KS1712 - Contact assignment

Terminal point		Description
Name	No.	
Input 1	1	Input 1
Mains voltage	2	Sensor supply (from power contact)
0 V	3	Sensor supply (from power contact)
PE	4	PE (from power contact)
Input 2	5	Input 2
Mains voltage	6	Sensor supply (from power contact)
0 V	7	Sensor supply (from power contact)
PE	8	PE (from power contact)

KL1702/KS1702, KL1712/KS1712 - LED Displays

LED	Color	Meaning	
Signal LED 1 - 2	green	off	Signal voltage "0"
		on	Signal voltage "1"

2.2 KL/KS1704 - Introduction

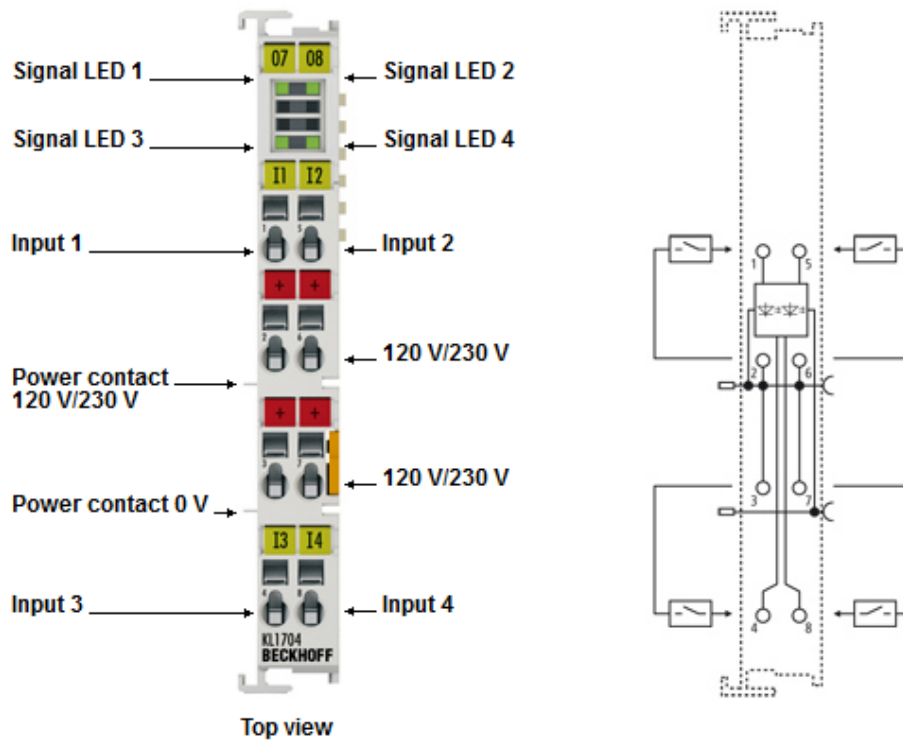

Fig. 3: KL1704

Four channel digital input terminal 120/230 V_{AC}

The KL/KS1704 digital input terminal acquires the binary control signals from the process level and transmits them, in an electrically isolated form, to the higher-level automation unit. The direct connection of 120/230 V_{AC} sensors is possible. The Bus Terminal has four channels, whose signal state is displayed by LEDs.

2.2.1 Technical data

Technical data	KL1704, KS1704
Connection technology	2 wire
Number of inputs	4
Nominal voltage	120/230 V _{AC}
Signal voltage '0'	0 V ... 40 V
Signal voltage '1'	79 V ... 260 V
Input filter	typ. 10 ms
Input current	4.6 mA typ. at 230 V, 2.3 mA typ. at 120 V
Current consumption from K-bus	typ. 3 mA
Switching times	10 ms
Electrical isolation	500 V (K-bus / field voltage), 3750 V _{AC} , 1 min.
Bit width in process image	4 input bits
Configuration	no address or configuration settings required
Special features	resistive/capacitive input behavior
Weight	app. 60 g
Permissible ambient temperature during operation	0°C ... +55°C
Permissible ambient temperature during storage	-25°C ... +85°C
Permissible relative humidity	95 %, no condensation
Vibration / shock resistance	conforms to EN 60068-2-6 / EN 60068-2-27
EMC immunity / emission	conforms to EN 61000-6-2 / EN 61000-6-4
Installation position	variable
Protection class	IP20
Pluggable wiring	for all KSxxxx terminals
Approvals / markings	CE, UKCA, cULus, EAC

2.2.2 Contact assignment and LEDs

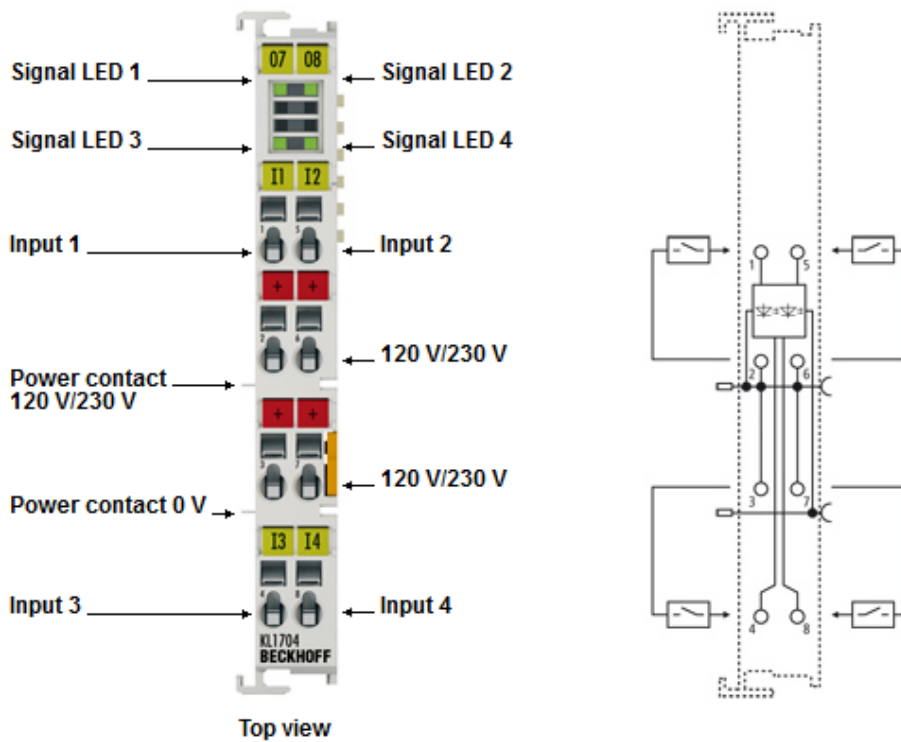

Fig. 4: KL1704/KS1704 - Contact assignment and LEDs

KL1704/KS1704 - Contact assignment

Terminal point		Description
Name	No.	
Input 1	1	Input 1
+120 V/230 V	2	Sensor supply (from power contact)
+120 V/230 V	3	Sensor supply (from power contact)
Input 3	4	Input 3
Input 2	5	Input 2
+120 V/230 V	6	Sensor supply (from power contact)
+120 V/230 V	7	Sensor supply (from power contact)
Input 4	8	Input 4

KL1704/KS1704 - LED Displays

LED	Color	Meaning	
Signal LED 1 - 4	green	off	Signal voltage "0" (0 V to 40 V)
		on	Signal voltage "1" (79 V to 260 V)

2.3 KL/KS1722 - Introduction

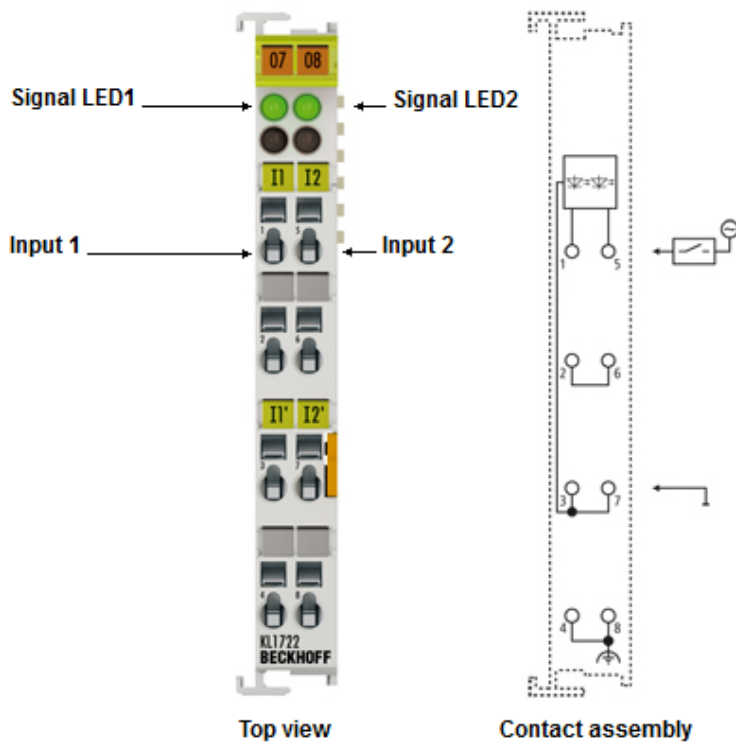

Fig. 5: KL1722

Two-channel digital input terminal 120/230 V_{AC}

The KL/KS1722 digital input terminal acquires the binary control signals from the process level and transmits them, in an electrically isolated form, to the higher-level automation unit. The direct connection of 120 V/230 V_{AC} sensors is possible. The Bus Terminal has two channels, whose signal state is displayed by LEDs. The terminal has no power contacts. This makes it possible to create individual potential groups. The voltage between input 1 and input 2 must not exceed 230 V_{AC}.

2.3.1 Technical data

Technical data	KL1722, KS1722
Connection technology	2 wire
Number of counters	2
Nominal voltage	120/230 V _{AC}
Signal voltage '0'	0 V ... 40 V
Signal voltage '1'	79 V ... 260 V
Input filter	typ. 10 ms
Input current	> 3 mA, typ. 6 mA
Current consumption from K-bus	typ. 3 mA
Switching times	10 ms
Electrical isolation	500 V (K-bus / field voltage), 3750 V _{AC} , 1 min.
Bit width in process image	2 input bits
Configuration	no address or configuration settings required
Special features	resistive/capacitive input behavior
Weight	app. 60 g
Permissible ambient temperature during operation	0°C ... +55°C
Permissible ambient temperature during storage	-25°C ... +85°C
Permissible relative humidity	95 %, no condensation
Vibration / shock resistance	according to EN 60068-2-6 / EN 60068-2-27, refer also to Installation instructions for enhanced mechanical load capacity [► 21]
EMC immunity / emission	conforms to EN 61000-6-2 / EN 61000-6-4
Installation position	variable
Protection class	IP20
Pluggable wiring	for all KSxxxx terminals
Approvals/markings	CE, UKCA, cULus, EAC, GL, ATEX

Ex marking

Standard	Marking
ATEX	II 3 G Ex nA IIC T4 Gc

2.3.2 Contact assignment and LEDs

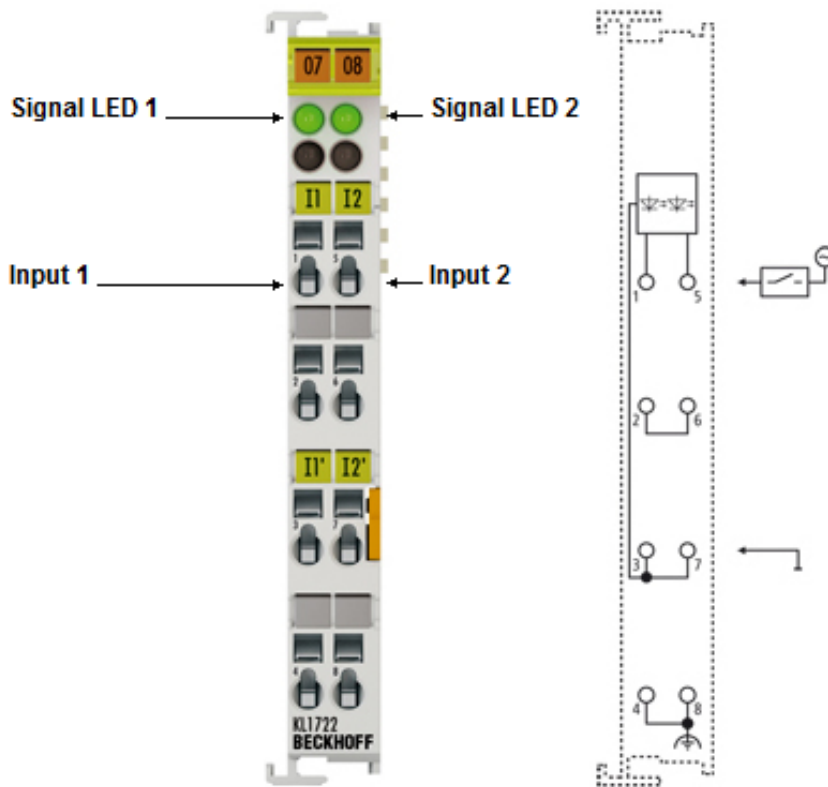

Fig. 6: KL1722 - Contact assignment and LEDs

KL1722/KS1722 - Contact assignment

Terminal point		Description
Name	No.	
Input 1	3	Input 1, neutral conductor, belonging to Input 1
Input 2	7	Input 2, neutral conductor, belonging to Input 2

KL1722/KS1722 - LED Displays

LED	Color	Meaning	
Signal LEDs 1 - 2	green	off	Signal voltage "0" (0 V ... 40 V)
		on	Signal voltage "1" (79 V ... 260 V)

3 Mounting and wiring

3.1 Instructions for ESD protection

NOTE

Destruction of the devices by electrostatic discharge possible!

The devices contain components at risk from electrostatic discharge caused by improper handling.

- Please ensure you are electrostatically discharged and avoid touching the contacts of the device directly.
- Avoid contact with highly insulating materials (synthetic fibers, plastic film etc.).
- Surroundings (working place, packaging and personnel) should be grounded probably, when handling with the devices.
- Each assembly must be terminated at the right hand end with a KL9010 bus end terminal, to ensure the protection class and ESD protection.

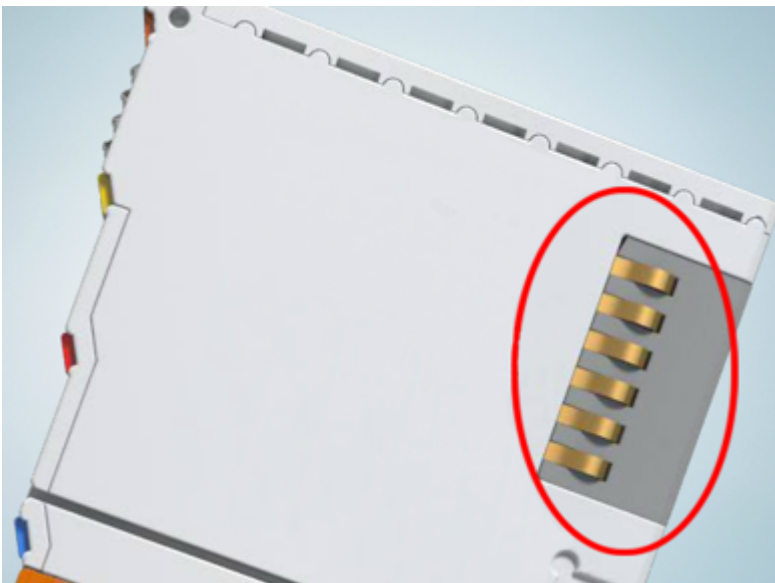

Fig. 7: Spring contacts of the Beckhoff I/O components

3.2 Installation on mounting rails

⚠ WARNING

Risk of electric shock and damage of device!

Bring the bus terminal system into a safe, powered down state before starting installation, disassembly or wiring of the bus terminals!

Assembly

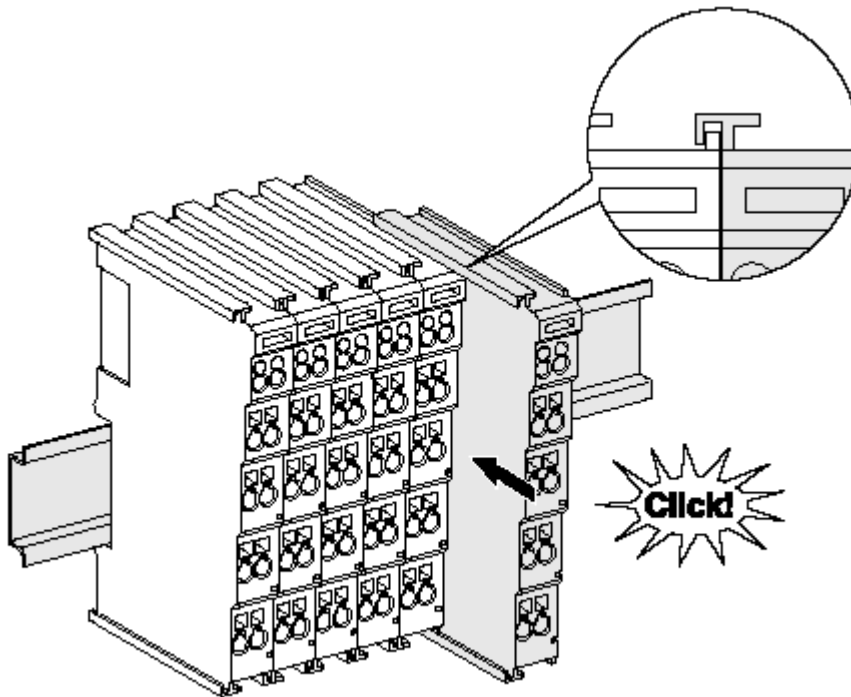

Fig. 8: Attaching on mounting rail

The bus coupler and bus terminals are attached to commercially available 35 mm mounting rails (DIN rails according to EN 60715) by applying slight pressure:

1. First attach the fieldbus coupler to the mounting rail.
2. The bus terminals are now attached on the right-hand side of the fieldbus coupler. Join the components with tongue and groove and push the terminals against the mounting rail, until the lock clicks onto the mounting rail.

If the terminals are clipped onto the mounting rail first and then pushed together without tongue and groove, the connection will not be operational! When correctly assembled, no significant gap should be visible between the housings.

i Fixing of mounting rails

The locking mechanism of the terminals and couplers extends to the profile of the mounting rail. At the installation, the locking mechanism of the components must not come into conflict with the fixing bolts of the mounting rail. To mount the mounting rails with a height of 7.5 mm under the terminals and couplers, you should use flat mounting connections (e.g. countersunk screws or blind rivets).

Disassembly

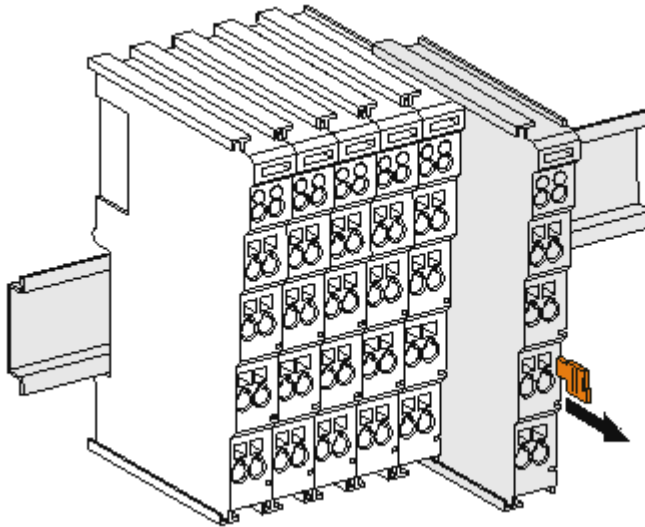

Fig. 9: Disassembling of terminal

Each terminal is secured by a lock on the mounting rail, which must be released for disassembly:

1. Pull the terminal by its orange-colored lugs approximately 1 cm away from the mounting rail. In doing so for this terminal the mounting rail lock is released automatically and you can pull the terminal out of the bus terminal block easily without excessive force.
2. Grasp the released terminal with thumb and index finger simultaneous at the upper and lower grooved housing surfaces and pull the terminal out of the bus terminal block.

Connections within a bus terminal block

The electric connections between the Bus Coupler and the Bus Terminals are automatically realized by joining the components:

- The six spring contacts of the K-Bus/E-Bus deal with the transfer of the data and the supply of the Bus Terminal electronics.
- The power contacts deal with the supply for the field electronics and thus represent a supply rail within the bus terminal block. The power contacts are supplied via terminals on the Bus Coupler (up to 24 V) or for higher voltages via power feed terminals.

i Power Contacts

During the design of a bus terminal block, the pin assignment of the individual Bus Terminals must be taken account of, since some types (e.g. analog Bus Terminals or digital 4-channel Bus Terminals) do not or not fully loop through the power contacts. Power Feed Terminals (KL91xx, KL92xx or EL91xx, EL92xx) interrupt the power contacts and thus represent the start of a new supply rail.

PE power contact

The power contact labeled PE can be used as a protective earth. For safety reasons this contact mates first when plugging together, and can ground short-circuit currents of up to 125 A.

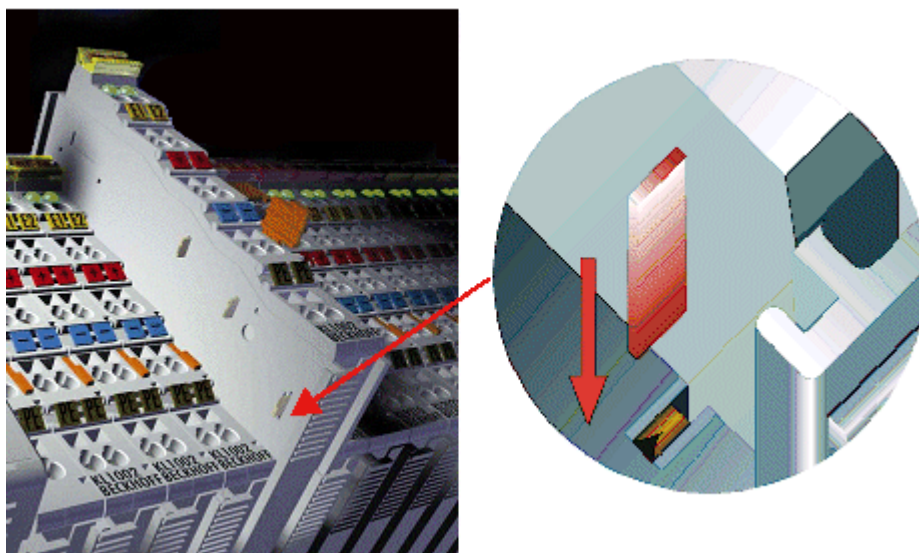

Fig. 10: Power contact on left side

NOTE**Possible damage of the device**

Note that, for reasons of electromagnetic compatibility, the PE contacts are capacitatively coupled to the mounting rail. This may lead to incorrect results during insulation testing or to damage on the terminal (e.g. disruptive discharge to the PE line during insulation testing of a consumer with a nominal voltage of 230 V). For insulation testing, disconnect the PE supply line at the Bus Coupler or the Power Feed Terminal! In order to decouple further feed points for testing, these Power Feed Terminals can be released and pulled at least 10 mm from the group of terminals.

⚠ WARNING**Risk of electric shock!**

The PE power contact must not be used for other potentials!

3.3 Installation instructions for enhanced mechanical load capacity

⚠ WARNING

Risk of injury through electric shock and damage to the device!

Bring the Bus Terminal system into a safe, de-energized state before starting mounting, disassembly or wiring of the Bus Terminals!

Additional checks

The terminals have undergone the following additional tests:

Verification	Explanation
Vibration	10 frequency runs in 3 axes
	6 Hz < f < 60 Hz displacement 0.35 mm, constant amplitude
	60.1 Hz < f < 500 Hz acceleration 5 g, constant amplitude
Shocks	1000 shocks in each direction, in 3 axes
	25 g, 6 ms

Additional installation instructions

For terminals with enhanced mechanical load capacity, the following additional installation instructions apply:

- The enhanced mechanical load capacity is valid for all permissible installation positions
- Use a mounting rail according to EN 60715 TH35-15
- Fix the terminal segment on both sides of the mounting rail with a mechanical fixture, e.g. an earth terminal or reinforced end clamp
- The maximum total extension of the terminal segment (without coupler) is: 64 terminals (12 mm mounting with) or 32 terminals (24 mm mounting with)
- Avoid deformation, twisting, crushing and bending of the mounting rail during edging and installation of the rail
- The mounting points of the mounting rail must be set at 5 cm intervals
- Use countersunk head screws to fasten the mounting rail
- The free length between the strain relief and the wire connection should be kept as short as possible. A distance of approx. 10 cm should be maintained to the cable duct.

3.4 Connection

3.4.1 Connection system

⚠ WARNING

Risk of electric shock and damage of device!

Bring the bus terminal system into a safe, powered down state before starting installation, disassembly or wiring of the bus terminals!

Overview

The bus terminal system offers different connection options for optimum adaptation to the respective application:

- The terminals of ELxxxx and KLxxxx series with standard wiring include electronics and connection level in a single enclosure.
- The terminals of ESxxxx and KSxxxx series feature a pluggable connection level and enable steady wiring while replacing.
- The High Density Terminals (HD Terminals) include electronics and connection level in a single enclosure and have advanced packaging density.

Standard wiring (ELxxxx / KLxxxx)



Fig. 11: Standard wiring

The terminals of ELxxxx and KLxxxx series have been tried and tested for years. They feature integrated screwless spring force technology for fast and simple assembly.

Pluggable wiring (ESxxxx / KSxxxx)



Fig. 12: Pluggable wiring

The terminals of ESxxxx and KSxxxx series feature a pluggable connection level. The assembly and wiring procedure is the same as for the ELxxxx and KLxxxx series. The pluggable connection level enables the complete wiring to be removed as a plug connector from the top of the housing for servicing. The lower section can be removed from the terminal block by pulling the unlocking tab. Insert the new component and plug in the connector with the wiring. This reduces the installation time and eliminates the risk of wires being mixed up.

The familiar dimensions of the terminal only had to be changed slightly. The new connector adds about 3 mm. The maximum height of the terminal remains unchanged.

A tab for strain relief of the cable simplifies assembly in many applications and prevents tangling of individual connection wires when the connector is removed.

Conductor cross sections between 0.08 mm² and 2.5 mm² can continue to be used with the proven spring force technology.

The overview and nomenclature of the product names for ESxxxx and KSxxxx series has been retained as known from ELxxxx and KLxxxx series.

High Density Terminals (HD Terminals)



Fig. 13: High Density Terminals

The terminals from these series with 16 terminal points are distinguished by a particularly compact design, as the packaging density is twice as large as that of the standard 12 mm bus terminals. Massive conductors and conductors with a wire end sleeve can be inserted directly into the spring loaded terminal point without tools.

● Wiring HD Terminals

i The High Density Terminals of the ELx8xx and KLx8xx series doesn't support pluggable wiring.

Ultrasonically “bonded” (ultrasonically welded) conductors

● Ultrasonically “bonded” conductors

i It is also possible to connect the Standard and High Density Terminals with ultrasonically “bonded” (ultrasonically welded) conductors. In this case, please note the tables concerning the wire-size width!

3.4.2 Wiring

⚠ WARNING

Risk of electric shock and damage of device!

Bring the bus terminal system into a safe, powered down state before starting installation, disassembly or wiring of the bus terminals!

Terminals for standard wiring ELxxxx/KLxxxx and for pluggable wiring ESxxxx/KSxxxx

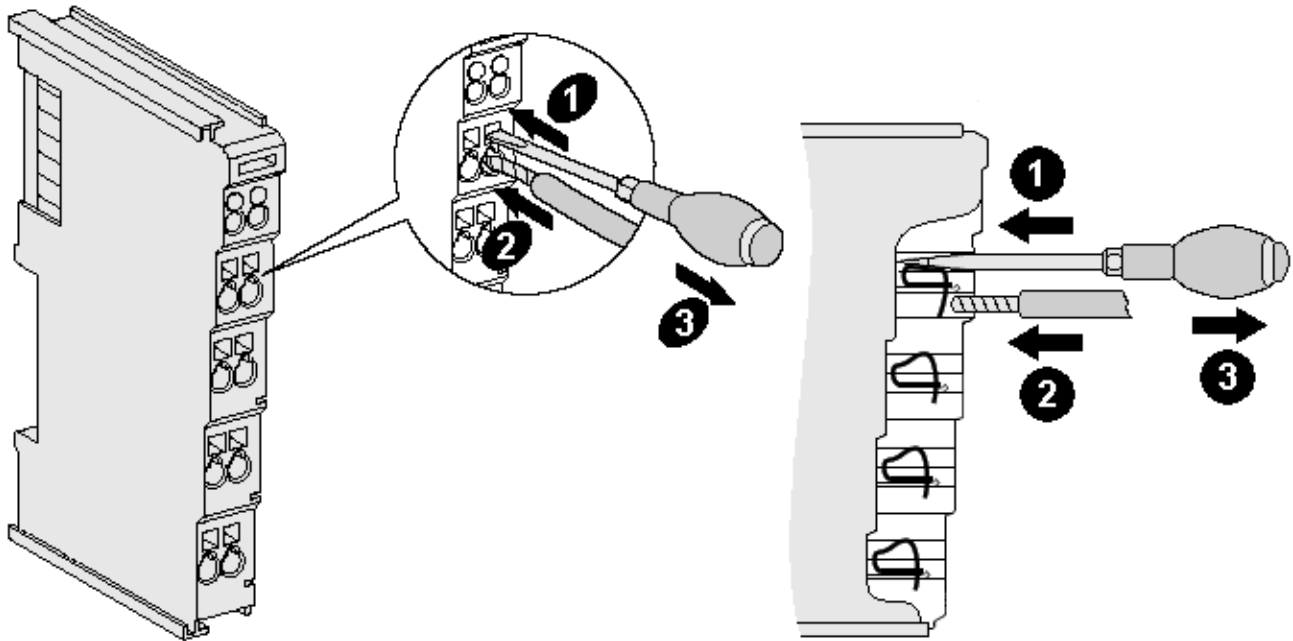

Fig. 14: Connecting a cable on a terminal point

Up to eight terminal points enable the connection of solid or finely stranded cables to the bus terminal. The terminal points are implemented in spring force technology. Connect the cables as follows:

1. Open a terminal point by pushing a screwdriver straight against the stop into the square opening above the terminal point. Do not turn the screwdriver or move it alternately (don't toggle).
2. The wire can now be inserted into the round terminal opening without any force.
3. The terminal point closes automatically when the pressure is released, holding the wire securely and permanently.

See the following table for the suitable wire size width.

Terminal housing	ELxxxx, KLxxxx	ESxxxx, KSxxxx
Wire size width (single core wires)	0.08 ... 2.5 mm ²	0.08 ... 2.5 mm ²
Wire size width (fine-wire conductors)	0.08 ... 2.5 mm ²	0,08 ... 2.5 mm ²
Wire size width (conductors with a wire end sleeve)	0.14 ... 1.5 mm ²	0.14 ... 1.5 mm ²
Wire stripping length	8 ... 9 mm	9 ... 10 mm

High Density Terminals (HD Terminals [[▶ 23](#)]) with 16 terminal points

The conductors of the HD Terminals are connected without tools for single-wire conductors using the direct plug-in technique, i.e. after stripping the wire is simply plugged into the terminal point. The cables are released, as usual, using the contact release with the aid of a screwdriver. See the following table for the suitable wire size width.

Terminal housing	High Density Housing
Wire size width (single core wires)	0.08 ... 1.5 mm ²
Wire size width (fine-wire conductors)	0.25 ... 1.5 mm ²
Wire size width (conductors with a wire end sleeve)	0.14 ... 0.75 mm ²
Wire size width (ultrasonically "bonded" conductors)	only 1.5 mm ²
Wire stripping length	8 ... 9 mm

3.4.3 Shielding



Shielding

Encoder, analog sensors and actors should always be connected with shielded, twisted paired wires.

3.5 ATEX - Special conditions (standard temperature range)

⚠ WARNING

Observe the special conditions for the intended use of Beckhoff fieldbus components with standard temperature range in potentially explosive areas (directive 2014/34/EU)!

- The certified components are to be installed in a suitable housing that guarantees a protection class of at least IP54 in accordance with EN 60079-15! The environmental conditions during use are thereby to be taken into account!
- For dust (only the fieldbus components of certificate no. KEMA 10ATEX0075 X Issue 9): The equipment shall be installed in a suitable enclosure providing a degree of protection of IP54 according to EN 60079-31 for group IIIA or IIIB and IP6X for group IIIC, taking into account the environmental conditions under which the equipment is used!
- If the temperatures during rated operation are higher than 70°C at the feed-in points of cables, lines or pipes, or higher than 80°C at the wire branching points, then cables must be selected whose temperature data correspond to the actual measured temperature values!
- Observe the permissible ambient temperature range of 0 to 55°C for the use of Beckhoff fieldbus components standard temperature range in potentially explosive areas!
- Measures must be taken to protect against the rated operating voltage being exceeded by more than 40% due to short-term interference voltages!
- The individual terminals may only be unplugged or removed from the Bus Terminal system if the supply voltage has been switched off or if a non-explosive atmosphere is ensured!
- The connections of the certified components may only be connected or disconnected if the supply voltage has been switched off or if a non-explosive atmosphere is ensured!
- The fuses of the KL92xx/EL92xx power feed terminals may only be exchanged if the supply voltage has been switched off or if a non-explosive atmosphere is ensured!
- Address selectors and ID switches may only be adjusted if the supply voltage has been switched off or if a non-explosive atmosphere is ensured!

Standards

The fundamental health and safety requirements are fulfilled by compliance with the following standards:

- EN 60079-0:2012+A11:2013
- EN 60079-15:2010
- EN 60079-31:2013 (only for certificate no. KEMA 10ATEX0075 X Issue 9)

Marking

The Beckhoff fieldbus components with standard temperature range certified according to the ATEX directive for potentially explosive areas bear one of the following markings:



II 3G KEMA 10ATEX0075 X Ex nA IIC T4 Gc Ta: 0 ... +55°C

II 3D KEMA 10ATEX0075 X Ex tc IIIC T135°C Dc Ta: 0 ... +55°C
(only for fieldbus components of certificate no. KEMA 10ATEX0075 X Issue 9)

or



II 3G KEMA 10ATEX0075 X Ex nA nC IIC T4 Gc Ta: 0 ... +55°C

II 3D KEMA 10ATEX0075 X Ex tc IIIC T135°C Dc Ta: 0 ... +55°C
(only for fieldbus components of certificate no. KEMA 10ATEX0075 X Issue 9)

3.6 Continulative documentation for ATEX and IECEx



Continulative documentation about explosion protection according to ATEX and IECEx

Pay also attention to the continuative documentation

Ex. Protection for Terminal Systems

Notes on the use of the Beckhoff terminal systems in hazardous areas according to ATEX and IECEx

that is available for [download](#) on the Beckhoff homepage www.beckhoff.com!

3.7 Disposal



Products marked with a crossed-out wheeled bin shall not be discarded with the normal waste stream. The device is considered as waste electrical and electronic equipment. The national regulations for the disposal of waste electrical and electronic equipment must be observed.

4 TwinCAT

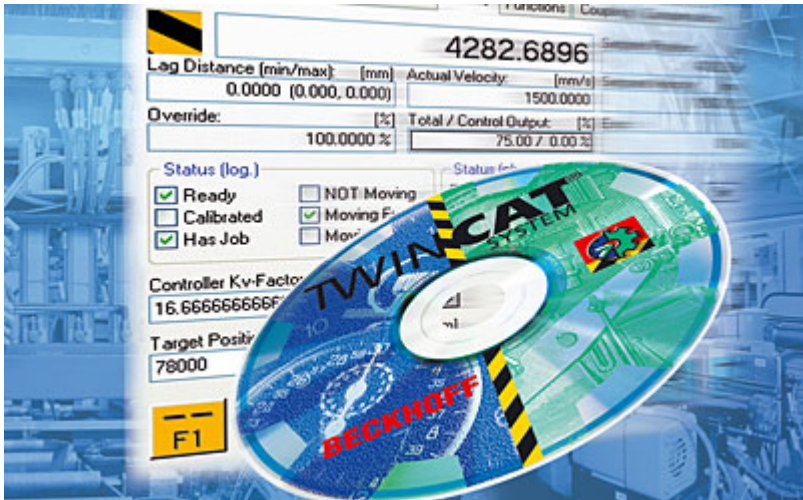

PLC and Motion Control on the PC

TwinCAT - The **Windows Control and Automation Technology**

The TwinCAT automation software converts any compatible PC into a real-time controller with multi-PLC, NC axis control, programming environment and operating station. TwinCAT replaces conventional PLC and NC controllers as well as operating devices:

- open, compatible PC hardware
- Embedding of IEC 61131-3 software PLC, software NC and software CNC in Windows NT/2000/XP, NT/XP Embedded, CE
- Programming and runtime systems optionally together on one PC or separated
- Connection to all common fieldbus systems
- PC interfaces are supported
- Data communication with user interfaces and other programs by means of open Microsoft standards (OPC, OCX, DLL, etc.)

TwinCAT architecture

TwinCAT consists of runtime systems for real-time execution of control programs and development environments for programming, diagnosis and configuration. Any Windows programs, for instance visualization programs or Office programs, can access TwinCAT data via Microsoft interfaces, or can execute commands.

A practically oriented software solution

TwinCAT offers a precise time-base in which programs are executed with the highest deterministic features, independently of other processor tasks. The real-time load on a PC is set with TwinCAT: This achieves a defined operating behavior. TwinCAT displays the system load for running programs. A loading threshold can be set, in order to assure a defined computing capacity for the operating programs and for Windows NT/2000/XP. If this threshold is exceeded, a system message is generated.

TwinCAT supports system diagnosis

The general use of hardware and software from the open PC world requires some checking: Unsuitable components can upset the PC system. Beckhoff integrates a handy display of the real-time jitter in order to provide administrators with a simple means of evaluating hardware and software. A system message during operation can draw attention to error states.

Start/stop behavior

Depending on the setting, TwinCAT is started and stopped manually or automatically. Since TwinCAT is integrated into Windows NT/2000/XP as a service, an operator is not needed to start the system: switching on is enough.

Restarting and data backup

When a program is started or restarted, TwinCAT loads programs and remanent data. To backup data, and to shut down Windows NT/2000/XP correctly, a UPS (uninterruptible power supply) is of great value.

TwinCAT and "Blue Screen"

The TwinCAT system can be configured such that real-time capability is maintained in the event of a BSOD (Blue-Screen-of-Death) operating system crash. Real-time tasks such as PLC and NC can thus continue to run and place the controlled process in a safe state. Ultimately, it is the decision of the programmer whether or not to utilize this feature, bearing in mind that data or programs may already have been destroyed by the BSOD.

World-wide connection through message routing - "remote" connection is inherent to the system

According to the requirement for operating resources, the TwinCAT software devices can be distributed: TwinCAT PLC programs can be executed on PCs and on Beckhoff Bus Terminal controllers. A "message router" manages and distributes all the messages, both in the system and via TCP/IP connections. PC systems can be connected to one another by TCP/IP; Bus Terminal controllers are connected via serial interfaces and fieldbus systems (EtherCAT, Lightbus, PROFIBUS DP, PROFINET, Interbus, CANopen, DeviceNet, RS232, RS485, Ethernet TCP/IP, Ethernet/IP).

World-wide access

Since standard TCP/IP services from Windows NT/2000/XP are used, this data exchange can take place worldwide. The system offers scalable communication capacity and timeout periods for the monitoring of communications. OPC provides a standardized means for accessing many different SCADA packets. The SOAP (Simple Object Access Protocol) enables a connection between two computers to be established by means of an internet connection via standard HTTP. A TwinCAT component is available for this purpose.

Beckhoff Information System

Further information on the TwinCAT automation software can be found in the Beckhoff Information System.

The setup for installing the Beckhoff Information System is available to you on the Beckhoff *Products & Solutions* DVD and on our website for [download](#).

In addition, the online version of the Beckhoff Information System can be found at <https://infosys.beckhoff.com>.

4.1 Programming

TwinCAT libraries

See software documentation in the Beckhoff Information System.

TwinCAT 2: TwinCAT PLC Lib: [I/O functions](#)

TwinCAT 3: TwinCAT 3 PLC Lib: [Tc2 IoFunctions](#)

5 Appendix

5.1 Support and Service

Beckhoff and their partners around the world offer comprehensive support and service, making available fast and competent assistance with all questions related to Beckhoff products and system solutions.

Beckhoff's branch offices and representatives

Please contact your Beckhoff branch office or representative for local support and service on Beckhoff products!

The addresses of Beckhoff's branch offices and representatives round the world can be found on her internet pages: <https://www.beckhoff.com>

You will also find further documentation for Beckhoff components there.

Beckhoff Support

Support offers you comprehensive technical assistance, helping you not only with the application of individual Beckhoff products, but also with other, wide-ranging services:

- support
- design, programming and commissioning of complex automation systems
- and extensive training program for Beckhoff system components

Hotline: +49 5246 963 157
Fax: +49 5246 963 9157
e-mail: support@beckhoff.com

Beckhoff Service

The Beckhoff Service Center supports you in all matters of after-sales service:

- on-site service
- repair service
- spare parts service
- hotline service

Hotline: +49 5246 963 460
Fax: +49 5246 963 479
e-mail: service@beckhoff.com

Beckhoff Headquarters

Beckhoff Automation GmbH & Co. KG

Huelshorstweg 20
33415 Verl
Germany

Phone: +49 5246 963 0
Fax: +49 5246 963 198
e-mail: info@beckhoff.com
web: <https://www.beckhoff.com>

Table of figures

Fig. 1	KL1702	8
Fig. 2	KL1702 - Contact assignment and LEDs.....	10
Fig. 3	KL1704	11
Fig. 4	KL1704/KS1704 - Contact assignment and LEDs.....	13
Fig. 5	KL1722	14
Fig. 6	KL1722 - Contact assignment and LEDs.....	16
Fig. 7	Spring contacts of the Beckhoff I/O components.....	17
Fig. 8	Attaching on mounting rail	18
Fig. 9	Disassembling of terminal.....	19
Fig. 10	Power contact on left side.....	20
Fig. 11	Standard wiring.....	22
Fig. 12	Pluggable wiring	22
Fig. 13	High Density Terminals.....	23
Fig. 14	Connecting a cable on a terminal point	24

More Information:
www.beckhoff.com/KL1xxx

Beckhoff Automation GmbH & Co. KG
Hülshorstweg 20
33415 Verl
Germany
Phone: +49 5246 9630
info@beckhoff.com
www.beckhoff.com

