

Documentation | EN

# BK9000, BK9050 and BK9100

Bus Coupler for Ethernet

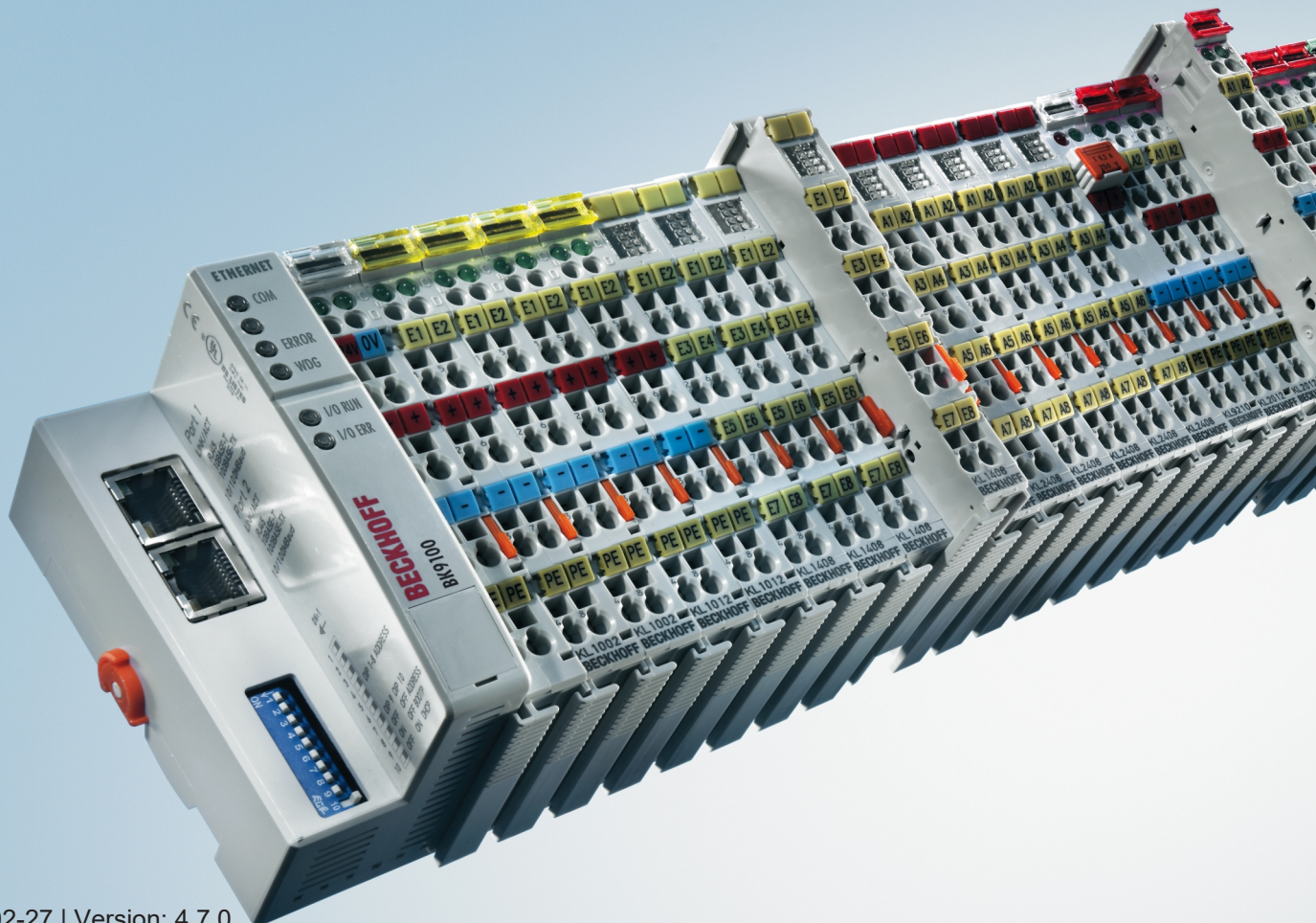



# Table of contents

<b>1 Foreword</b> .....	<b>5</b>
1.1 Notes on the documentation .....	5
1.2 Safety instructions .....	6
1.3 Notes on information security.....	7
1.4 Documentation issue status .....	8
<b>2 Product overview</b> .....	<b>10</b>
2.1 BK9000, BK9050 – Introduction .....	10
2.2 BK9100 - introduction.....	11
2.3 Technical data .....	12
2.4 The Beckhoff Bus Terminal system .....	13
2.5 The principle of the Bus Terminal .....	15
2.6 Ethernet.....	15
<b>3 Mounting and wiring</b> .....	<b>17</b>
3.1 Instructions for ESD protection .....	17
3.2 Mounting .....	18
3.2.1 Dimensions .....	18
3.2.2 Installation on mounting rails.....	20
3.3 Disposal .....	21
3.4 Wiring .....	22
3.4.1 Power supply, potential groups .....	22
3.4.2 Ethernet connection .....	23
3.4.3 Ethernet topologies .....	24
3.4.4 Ethernet cable .....	26
3.5 ATEX - Special conditions (standard temperature range).....	28
3.6 ATEX - Special conditions (extended temperature range).....	29
3.7 Continuative documentation for ATEX and IECEx.....	30
<b>4 Parameterization and commissioning</b> .....	<b>31</b>
4.1 Start-up behaviour of the Bus Coupler.....	31
4.2 Parameterization of the Bus Coupler using DIP switches .....	32
4.3 Network classes .....	33
4.4 IP address .....	34
4.4.1 IP address .....	34
4.4.2 Configuration with KS2000.....	34
4.4.3 Setting the IP address using the ARP table.....	35
4.4.4 Setting the IP Address Using the Beckhoff BootP Server.....	36
4.4.5 Setting the address using a DHCP server .....	37
4.4.6 Subnet mask .....	37
4.4.7 Testing the IP address .....	38
4.4.8 Reading the MAC-ID .....	38
<b>5 Configuration</b> .....	<b>39</b>
5.1 ModbusTCP .....	39
5.1.1 ModbusTCP Process Image .....	39
5.2 Mapping the Bus Terminals .....	40

5.3	TwinCAT System Manager .....	40
5.3.1	Configuration using the System Manager .....	40
5.3.2	ADS Process Image .....	42
5.3.3	The IP Address tab .....	43
<b>6</b>	<b>Fieldbus system .....</b>	<b>45</b>
6.1	Ethernet .....	45
6.2	Topology .....	47
6.3	Reaction times .....	47
6.4	Real-time Ethernet .....	49
6.4.1	Real-time Ethernet with Fast-ADS .....	49
6.5	ADS-Communication .....	51
6.5.1	ADS-Communication .....	51
6.5.2	ADS protocol .....	52
6.5.3	ADS services .....	53
6.5.4	AMS routing table .....	55
6.6	ModbusTCP .....	56
6.6.1	Examples for ModbusTCP .....	56
6.6.2	ModbusTCP Protocol .....	57
6.6.3	Modbus TCP interface .....	58
6.6.4	ModbusTCP slave error answer (BK9000, BX/BC9xx0, BC9191, IP/ILxxx-B/C900, EK9000) .....	59
6.6.5	ModbusTCP functions .....	60
6.7	Description of parameters .....	68
6.7.1	Register settings, Table 100 .....	68
<b>7</b>	<b>Error handling and diagnosis .....</b>	<b>69</b>
7.1	Diagnostic LEDs .....	69
7.2	Diagnostic LEDs .....	72
7.3	General errors .....	73
7.4	ADS diagnostics .....	74
7.5	ModbusTCP diagnostic .....	76
<b>8</b>	<b>Appendix .....</b>	<b>77</b>
8.1	General operating conditions .....	77
8.2	Approvals .....	78
8.3	Test standards for device testing .....	78
8.4	Bibliography .....	79
8.5	List of Abbreviations .....	79
8.6	Beckhoff Identification Code (BIC) .....	80
8.7	Support and Service .....	82

# 1 Foreword

## 1.1 Notes on the documentation

### Intended audience

This description is only intended for the use of trained specialists in control and automation engineering who are familiar with the applicable national standards.

It is essential that the documentation and the following notes and explanations are followed when installing and commissioning these components.

It is the duty of the technical personnel to use the documentation published at the respective time of each installation and commissioning.

The responsible staff must ensure that the application or use of the products described satisfy all the requirements for safety, including all the relevant laws, regulations, guidelines and standards.

### Disclaimer

The documentation has been prepared with care. The products described are, however, constantly under development.

We reserve the right to revise and change the documentation at any time and without prior announcement.

No claims for the modification of products that have already been supplied may be made on the basis of the data, diagrams and descriptions in this documentation.

### Trademarks

Beckhoff®, TwinCAT®, TwinCAT/BSD®, TC/BSD®, EtherCAT®, EtherCAT G®, EtherCAT G10®, EtherCAT P®, Safety over EtherCAT®, TwinSAFE®, XFC®, XTS® and XPlanar® are registered trademarks of and licensed by Beckhoff Automation GmbH. Other designations used in this publication may be trademarks whose use by third parties for their own purposes could violate the rights of the owners.

### Patent Pending

The EtherCAT Technology is covered, including but not limited to the following patent applications and patents: EP1590927, EP1789857, EP1456722, EP2137893, DE102015105702 with corresponding applications or registrations in various other countries.



EtherCAT® is registered trademark and patented technology, licensed by Beckhoff Automation GmbH, Germany.

### Copyright

© Beckhoff Automation GmbH & Co. KG, Germany.

The reproduction, distribution and utilization of this document as well as the communication of its contents to others without express authorization are prohibited.

Offenders will be held liable for the payment of damages. All rights reserved in the event of the grant of a patent, utility model or design.



## 1.2 Safety instructions

### Safety regulations

Please note the following safety instructions and explanations!  
Product-specific safety instructions can be found on following pages or in the areas mounting, wiring, commissioning etc.

### Exclusion of liability

All the components are supplied in particular hardware and software configurations appropriate for the application. Modifications to hardware or software configurations other than those described in the documentation are not permitted, and nullify the liability of Beckhoff Automation GmbH & Co. KG.

### Personnel qualification

This description is only intended for trained specialists in control, automation and drive engineering who are familiar with the applicable national standards.

### Description of instructions

In this documentation the following instructions are used.  
These instructions must be read carefully and followed without fail!

#### DANGER

##### Serious risk of injury!

Failure to follow this safety instruction directly endangers the life and health of persons.

#### WARNING

##### Risk of injury!

Failure to follow this safety instruction endangers the life and health of persons.

#### CAUTION

##### Personal injuries!

Failure to follow this safety instruction can lead to injuries to persons.

#### NOTE

##### Damage to environment/equipment or data loss

Failure to follow this instruction can lead to environmental damage, equipment damage or data loss.



##### Tip or pointer

This symbol indicates information that contributes to better understanding.

## 1.3 Notes on information security

The products of Beckhoff Automation GmbH & Co. KG (Beckhoff), insofar as they can be accessed online, are equipped with security functions that support the secure operation of plants, systems, machines and networks. Despite the security functions, the creation, implementation and constant updating of a holistic security concept for the operation are necessary to protect the respective plant, system, machine and networks against cyber threats. The products sold by Beckhoff are only part of the overall security concept. The customer is responsible for preventing unauthorized access by third parties to its equipment, systems, machines and networks. The latter should be connected to the corporate network or the Internet only if appropriate protective measures have been set up.

In addition, the recommendations from Beckhoff regarding appropriate protective measures should be observed. Further information regarding information security and industrial security can be found in our <https://www.beckhoff.com/secguide>.

Beckhoff products and solutions undergo continuous further development. This also applies to security functions. In light of this continuous further development, Beckhoff expressly recommends that the products are kept up to date at all times and that updates are installed for the products once they have been made available. Using outdated or unsupported product versions can increase the risk of cyber threats.

To stay informed about information security for Beckhoff products, subscribe to the RSS feed at <https://www.beckhoff.com/secinfo>.

## 1.4 Documentation issue status

Version	Modifications
4.7.0	<ul style="list-style-type: none"> <li>Chapter <i>Diagnostic LEDs</i> updated</li> </ul>
4.6.0	<ul style="list-style-type: none"> <li>Technical data updated</li> <li>Ex markings added to technical data</li> <li>Chapter <i>Notes on information security</i> added</li> <li>Chapter <i>Instructions for ESD protection</i> added</li> <li>Chapter <i>Disposal</i> added</li> <li>New title page</li> </ul>
4.5.0	<ul style="list-style-type: none"> <li>Chapter <i>Register settings, Table 100</i> updated</li> </ul>
4.4.0	<ul style="list-style-type: none"> <li>Technical data updated</li> </ul>
4.3.0	<ul style="list-style-type: none"> <li>Technical data updated</li> <li>Chapter <i>Beckhoff Identification Code (BIC)</i> added</li> </ul>
4.2.0	<ul style="list-style-type: none"> <li>Technical data updated</li> <li>Design of the safety instructions adapted to IEC 82079-1</li> <li>Chapter <i>Installation on mounting rails</i> updated</li> <li>ATEX notes added</li> <li>Corrections</li> </ul>
4.1.0	<ul style="list-style-type: none"> <li>extended temperature range for BK9000 and BK9100</li> </ul>
4.0.0	<ul style="list-style-type: none"> <li>Migration</li> <li>Update structure</li> </ul>
3.9.0	<ul style="list-style-type: none"> <li>Description of the BK9050 added</li> </ul>
3.8.2	<ul style="list-style-type: none"> <li>Description of the BK9100 added</li> <li>Description of the Modbus-TCP function corrected</li> </ul>
3.8.1	<ul style="list-style-type: none"> <li>Description of the RT-Ethernet added</li> </ul>

### Firmware and hardware versions

Documentation Version	BK9000		BK9100		BK9050	
	Firmware	Hardware	Firmware	Hardware	Firmware	Hardware
4.7.0	BD	19	B6	12	B3	09
4.6.0	BD	19	B6	11	B3	09
4.5.0	BD	18	B6	10	B3	07
4.4.0	BD	18	B6	10	B3	07
4.3.0	BD	18	B6	10	B3	06
4.2.0	BD	18	B6	10	B3	06
4.1.0	BD	18	B6	10	B3	04
4.0.0	BD	18	B6	10	B3	04
3.9.0	BC	12	B1	03	B0	00
3.8.2	BA	11	B1	00	-	-
3.8.1	B8	10	-	-	-	-
3.8	B8	10	-	-	-	-

You can determine which firmware was fitted when the Bus Coupler left the factory from the adhesive label underneath (see the fifth and sixth figures of the production number).

Example: 3200**B**2020000 - The firmware in the example is B2.

The KS2000 configuration software and the corresponding serial cable included with, is required for updating your firmware. You can also update your coupler using the System Manager from TwinCAT version 2.8 (in the case of the BK9000 only from firmware version B6).



**Notes on the firmware versions**

**BK9000**

Firmware	Description
BD	<ul style="list-style-type: none"> <li>• Modbus/TCP: protocol extended</li> </ul>
BC	<ul style="list-style-type: none"> <li>• Start-up improved</li> </ul>
BB	<ul style="list-style-type: none"> <li>• Link detection changed</li> </ul>
BA	<ul style="list-style-type: none"> <li>• Supports TwinSAFE terminals (KL1904, KL2904 and KL6904)</li> </ul>
B8	<ul style="list-style-type: none"> <li>• In the event of watchdog errors the analog outputs are now set to zero</li> <li>• RT-Ethernet implemented</li> </ul>
B7	<ul style="list-style-type: none"> <li>• Error in the B6 version related to mapping the KL60xx Bus Terminals corrected</li> </ul>
B6	<ul style="list-style-type: none"> <li>• Internal software reset modified (this does not have any effects that concern the user)</li> </ul>
B5	<ul style="list-style-type: none"> <li>• Fast ModbusTCP implemented</li> </ul>
B4	<ul style="list-style-type: none"> <li>• Settings such as the IP address are retained during a firmware update</li> </ul>
B3	<ul style="list-style-type: none"> <li>• Firmware update over Ethernet possible</li> <li>• Reading out the configuration with the System Manager (as from TwinCAT 2.8) possible</li> <li>• ADS access control through table 2 implemented</li> </ul>
B2	<ul style="list-style-type: none"> <li>• Addressing via ARP, DHCP and BootP possible</li> <li>• Access to process inputs with FC3 ModbusTCP implemented</li> </ul>
B1	<ul style="list-style-type: none"> <li>• Watchdog LED triggered under ModbusTCP</li> </ul>
B0	<ul style="list-style-type: none"> <li>• First released version</li> </ul>

**BK9050**

Firmware	Description
B3	<ul style="list-style-type: none"> <li>• Modbus/TCP: protocol extended</li> </ul>
B2	<ul style="list-style-type: none"> <li>• K-bus reset via ADS implemented (ADS control)</li> </ul>
B1	<ul style="list-style-type: none"> <li>• IP address was not secured after addressing via "ARP"</li> </ul>
B0	<ul style="list-style-type: none"> <li>• First released version</li> </ul>

**BK9100**

Firmware	Description
B6	<ul style="list-style-type: none"> <li>• Modbus watchdog can be written again (error in FW B5)</li> </ul>
B2-B5	<ul style="list-style-type: none"> <li>• Internet changes</li> </ul>
B1	<ul style="list-style-type: none"> <li>• Supports TwinSAFE terminals (KL1904, KL2904 and KL6904)</li> </ul>
B0	<ul style="list-style-type: none"> <li>• First released version</li> </ul>

## 2 Product overview

### 2.1 BK9000, BK9050 – Introduction

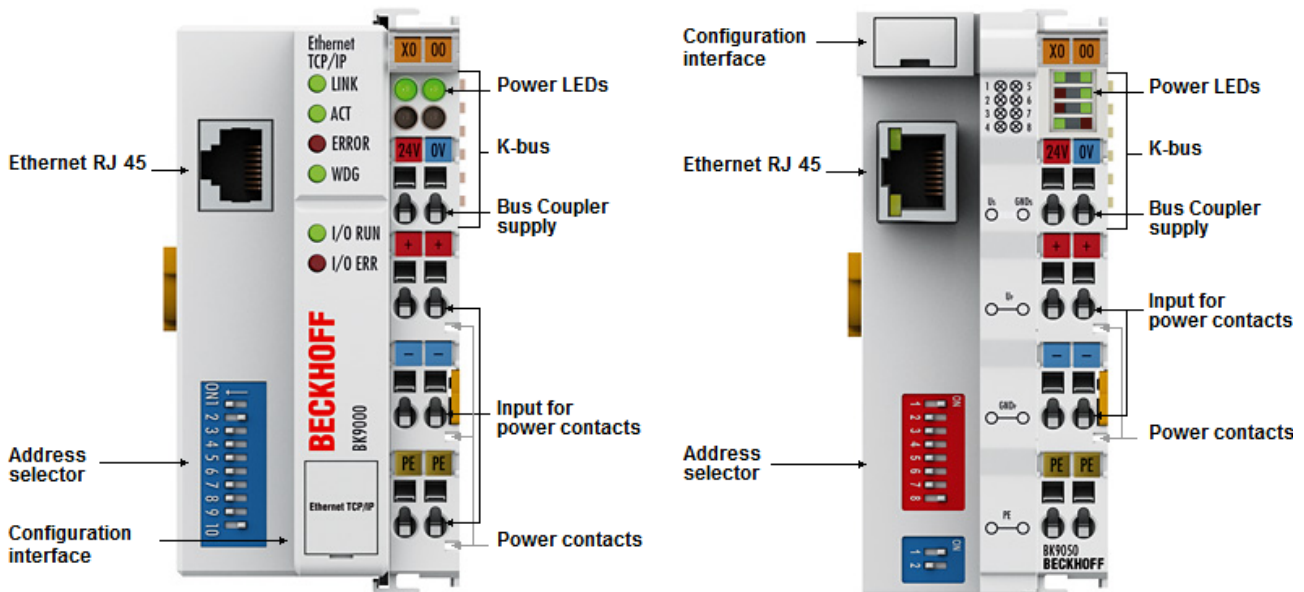

Fig. 1: BK9000, BK9050

The BK9000 and BK9050 Bus Couplers connect Ethernet with the modular, extendable electronic terminal blocks. One unit consists of one Bus Coupler, any number from 1 to 64 terminals and one end terminal. The "Compact" BK9050 Bus Coupler is a cost-optimized version with compact housing. With the K-bus extension, up to 255 Bus Terminals can be connected.

The Bus Couplers recognize the terminals to which they are connected, and perform the assignment of the inputs and outputs to the words of the process image automatically. The BK9000 and BK9050 Bus Couplers support 10 Mbit/s and 100 Mbit/s Ethernet. Connection is through normal RJ 45 connectors. The IP address is set on the DIP switch (offset to a freely selectable start address). In networks with DHCP (a service for the allocation of the logical IP address to the physical node address (MAC-ID)) the Bus Coupler obtains its IP address from the DHCP server.

The BK9000 and BK9050 Bus Couplers support ADS TwinCAT system communication. TwinCAT I/O makes available configuration tools and Windows-NT//2000/XP drivers for programs in any desired high-level language (DLLs) and for Visual Basic applications (ActiveX). Applications with OPC interfaces can access ADS (and therefore the BK9000 or BK9050) via an OPC server. In addition to ADS the Bus Coupler supports Open Modbus (Modbus TCP), a simple master/slave protocol based on TCP/IP in wide application.

#### Complex signal processing for analog I/Os, displacement measurement, etc.

The BK9000 and BK9050 Bus Couplers support the operation of all Bus Terminal types. As far as the user is concerned, the inputs and outputs are not handled any differently from the way they are with other coupler series. The information is made available for use as a byte array in the process image of the automation device.

The KS2000 configuration software allows the analog and multifunctional Bus Terminals to be adapted to the specific application. Depending on the type, the registers of the analog Bus Terminals contain temperature ranges, gain factors and linearization characteristic curves, which are parameterized via the PC using the KS2000. The Bus Terminal stores the setting permanently, even if the voltage supply fails.

Having the controller (PLC, IPC) carry out the configuration of the Bus Terminals is a further option. The PLC or IPC uses function blocks (FB) to take care of the configuration of all the peripherals during the start-up phase. The controller can, if required, upload the non-centrally generated configuration data in order to manage and store them centrally. The replacement of a Bus Terminal does not necessitate new settings. The controller carries out the desired setting automatically after switching on.

## 2.2 BK9100 - introduction

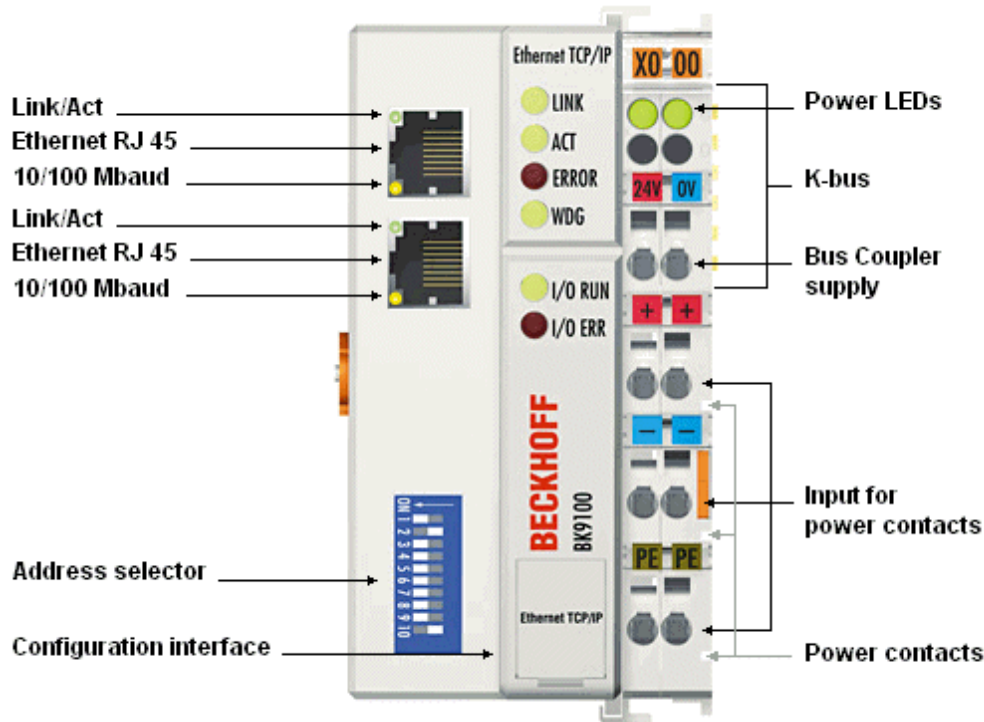

Fig. 2: BK9100

The BK9100 Bus Coupler connects Ethernet with the modular, extendable electronic terminal blocks. One unit consists of one Bus Coupler, any number from 1 to 64 terminals and one end terminal. The connected terminals are recognized by the Bus Coupler and the assignment of the inputs/outputs to the words in the process image is created automatically. The BK9100 Bus Coupler supports 10 Mbit/s and 100 Mbit/s Ethernet. Connection is through normal RJ 45 connectors. The IP address is set on the DIP switch (offset to a freely selectable start address). In networks with DHCP (a service for the allocation of the logical IP address to the physical node address (MAC-ID)) the Bus Coupler obtains its IP address from the DHCP server.

Unlike the BK9000, the BK9100 has an additional RJ 45 port. Both Ethernet ports operate as 2-channel switches. The I/O stations can thus be configured with a line topology, instead of the classic star topology. In many applications; this significantly reduces the wiring effort and the cabling costs. The maximum distance between two couplers is 100 m. Up to 20 BK9100 Bus Couplers are cascadable, so that a maximum line length of 2 km can be achieved.

The BK9100 support ADS TwinCAT system communication. TwinCAT I/O makes available configuration tools and Windows/2000/XP drivers for programs in any desired high-level language (DLLs) and for Visual Basic applications (ActiveX). Applications with OPC interfaces can access ADS (and therefore the BK9100 or BK9050) via an OPC server. In addition to ADS the Bus Coupler supports Open Modbus (Modbus TCP), a simple master/slave protocol based on TCP/IP in wide application.

### Complex signal processing for analog I/Os, displacement measurement, etc.

The BK9100 Bus Coupler supports the operation of all Bus Terminal types. As far as the user is concerned, the inputs and outputs are not handled any differently from the way they are with other coupler series. The information is made available for use as a byte array in the process image of the automation device.

The KS2000 configuration software allows the analog and multifunctional Bus Terminals to be adapted to the specific application. Depending on the type, the registers of the analog Bus Terminals contain temperature ranges, gain factors and linearization characteristic curves, which are parameterized via the PC using the KS2000. The Bus Terminal stores the setting permanently, even if the voltage supply fails.

Having the controller (PLC, IPC) carry out the configuration of the Bus Terminals is a further option. The PLC or IPC uses function blocks (FB) to take care of the configuration of all the peripherals during the start-up phase. The controller can, if required, upload the non-centrally generated configuration data in order to manage and store them centrally. The replacement of a Bus Terminal does not necessitate new settings. The controller carries out the desired setting automatically after switching on.

## 2.3 Technical data

Technical data	BK9000	BK9050	BK9100
Number of Bus Terminals	64	64 (255 with K-bus extension)	64
Digital peripheral signals	512 inputs/outputs	1020 inputs/outputs	512 inputs/outputs
Analog peripheral signals	128 inputs/outputs		
Protocols	UDP- ADS, TCP-ADS, RT-Ethernet, ModbusTCP/Fast ModbusTCP		
Configuration possibility	Via the KS2000 configuration software or the controller (TwinCAT)		
Maximum number of bytes	512 bytes of input data and 512 bytes of output data		
Bus connection	1 x RJ 45	1 x RJ 45	2 x RJ 45
Power supply	24 V <sub>DC</sub> (-15%/+20%)		
Input current	70 mA + (total K-bus current)/4, 4.500 mA max.		
Starting current	approx. 2.5 x continuous current		
K-bus power supply up to	1750 mA		
Power contact voltage	maximum 24 V <sub>DC</sub>		
Power contact current load	maximum 10 A		
Dielectric strength	500 V (power contact/supply voltage/Ethernet/fieldbus)		
Recommended fuse	≤ 10 A		
Weight	ca. 170 g	ca. 100 g	ca. 170 g
Permissible ambient temperature range during operation	-25°C ... +60°C	0°C ... +55°C	-25°C ... +60°C
Permissible ambient temperature range during storage	-40°C ... +85°C	-25°C ... +85°C	-40°C ... +85°C
Permissible relative humidity	95%, no condensation		
Vibration/shock resistance	conforms to EN 60068-2-6 / EN 60068-2-27		
EMC immunity/emission	conforms to EN 61000-6-2 / EN 61000-6-4		
Installation position	variable		
Protection class	IP20		
Approvals/markings*	CE, UKCA, cULus, EAC, GL, ATEX [ <a href="#">▶ 29</a> ]	CE, UKCA, cULus, EAC, GL, ATEX [ <a href="#">▶ 28</a> ]	CE, UKCA, cULus, EAC, GL, ATEX [ <a href="#">▶ 29</a> ]

\*) Real applicable approvals/markings see type plate on the side (product marking).

### Ex marking

Standard	Marking
ATEX	II 3 G Ex nA IIC T4 Gc

System data	BK9000	BK9050	BK9100
Number of I/O modules	only limited by the IP address space		
Number of I/O points	depending on controller		
Transmission medium	4 x 2 twisted pair copper cable; category 3 (10 Mbaud), category 5 (100 Mbaud)		
Distance between modules	100 m		
Data transfer rate	10/100 Mbaud		
Topology	star wiring	star wiring	line or star wiring
Cascading	-	-	up to 20 BK9100 or max. line length 2 km

## 2.4 The Beckhoff Bus Terminal system

### Up to 256 Bus Terminals, with 1 to 16 I/O channels per signal form

The Bus Terminal system is the universal interface between a fieldbus system and the sensor / actuator level. A unit consists of a Bus Coupler as the head station, and up to 64 electronic series terminals, the last one being an end terminal. Up to 255 Bus Terminals can be connected via the K-Bus extension. For each technical signal form, terminals are available with one, two, four or eight I/O channels, which can be mixed as required. All the terminal types have the same mechanical construction, so that difficulties of planning and design are minimized. The height and depth match the dimensions of compact terminal boxes.

### Decentralized wiring of each I/O level

Fieldbus technology allows more compact forms of controller to be used. The I/O level does not have to be brought to the controller. The sensors and actuators can be wired decentrally, using minimum cable lengths. The controller can be installed at any location within the plant.

### Industrial PCs as controllers

The use of an Industrial PC as the controller means that the operating and observing element can be implemented in the controller's hardware. The controller can therefore be located at an operating panel, in a control room, or at some similar place. The Bus Terminals form the decentralized input/output level of the controller in the control cabinet and the subsidiary terminal boxes. The power sector of the plant is also controlled over the bus system in addition to the sensor/actuator level. The Bus Terminal replaces the conventional series terminal as the wiring level in the control cabinet. The control cabinet can have smaller dimensions.

### Bus Couplers for all usual bus systems

The Beckhoff Bus Terminal system unites the advantages of a bus system with the possibilities of the compact series terminal. Bus Terminals can be driven within all the usual bus systems, thus reducing the controller parts count. The Bus Terminals then behave like conventional connections for that bus system. All the performance features of the particular bus system are supported.

### Mounting on standardized mounting rails

The installation is standardized thanks to the simple and space-saving mounting on a standardized mounting rail (EN 60715, 35 mm) and the direct wiring of actuators and sensors, without cross connections between the terminals. The consistent labelling scheme also contributes.

The small physical size and the great flexibility of the Bus Terminal system allow it to be used wherever a series terminal is also used. Every type of connection, such as analog, digital, serial or the direct connection of sensors can be implemented.

## **Modularity**

The modular assembly of the terminal strip with Bus Terminals of various functions limits the number of unused channels to a maximum of one per function. The presence of two channels in one terminal is the optimum compromise of unused channels and the cost of each channel. The possibility of electrical isolation through potential feed terminals also helps to keep the number of unused channels low.

## **Display of the channel state**

The integrated LEDs show the state of the channel at a location close to the sensors and actuators.

## **K-Bus**

The K-Bus is the data path within a terminal strip. The K-Bus is led through from the Bus Coupler through all the terminals via six contacts on the terminals' side walls. The end terminal terminates the K-Bus. The user does not have to learn anything about the function of the K-Bus or about the internal workings of the terminals and the Bus Coupler. Many software tools that can be supplied make project planning, configuration and operation easy.

## **Potential feed terminals for isolated groups**

The operating voltage is passed on to following terminals via three power contacts. You can divide the terminal strip into arbitrary isolated groups by means of potential feed terminals. The potential feed terminals play no part in the control of the terminals, and can be inserted at any locations within the terminal strip.

Up to 64 Bus Terminals can be used in a terminal block, with optional K-Bus extension for up to 256 Bus Terminals. This count does include potential feed terminals, but not the end terminal.

## **Bus Couplers for various fieldbus systems**

Various Bus Couplers can be used to couple the electronic terminal strip quickly and easily to different fieldbus systems. It is also possible to convert to another fieldbus system at a later time. The Bus Coupler performs all the monitoring and control tasks that are necessary for operation of the connected Bus Terminals. The operation and configuration of the Bus Terminals is carried out exclusively by the Bus Coupler. Nevertheless, the parameters that have been set are stored in each Bus Terminal, and are retained in the event of voltage drop-out. Fieldbus, K-Bus and I/O level are electrically isolated.

If the exchange of data over the fieldbus is prone to errors or fails for a period of time, register contents (such as counter states) are retained, digital outputs are cleared, and analog outputs take a value that can be configured for each output when commissioning. The default setting for analog outputs is 0 V or 0 mA. Digital outputs return in the inactive state. The timeout periods for the Bus Couplers correspond to the usual settings for the fieldbus system. When converting to a different bus system it is necessary to bear in mind the need to change the timeout periods if the bus cycle time is longer.

## **The interfaces**

A Bus Coupler has six different methods of connection. These interfaces are designed as plug connectors and as spring-loaded terminals.



## 2.5 The principle of the Bus Terminal

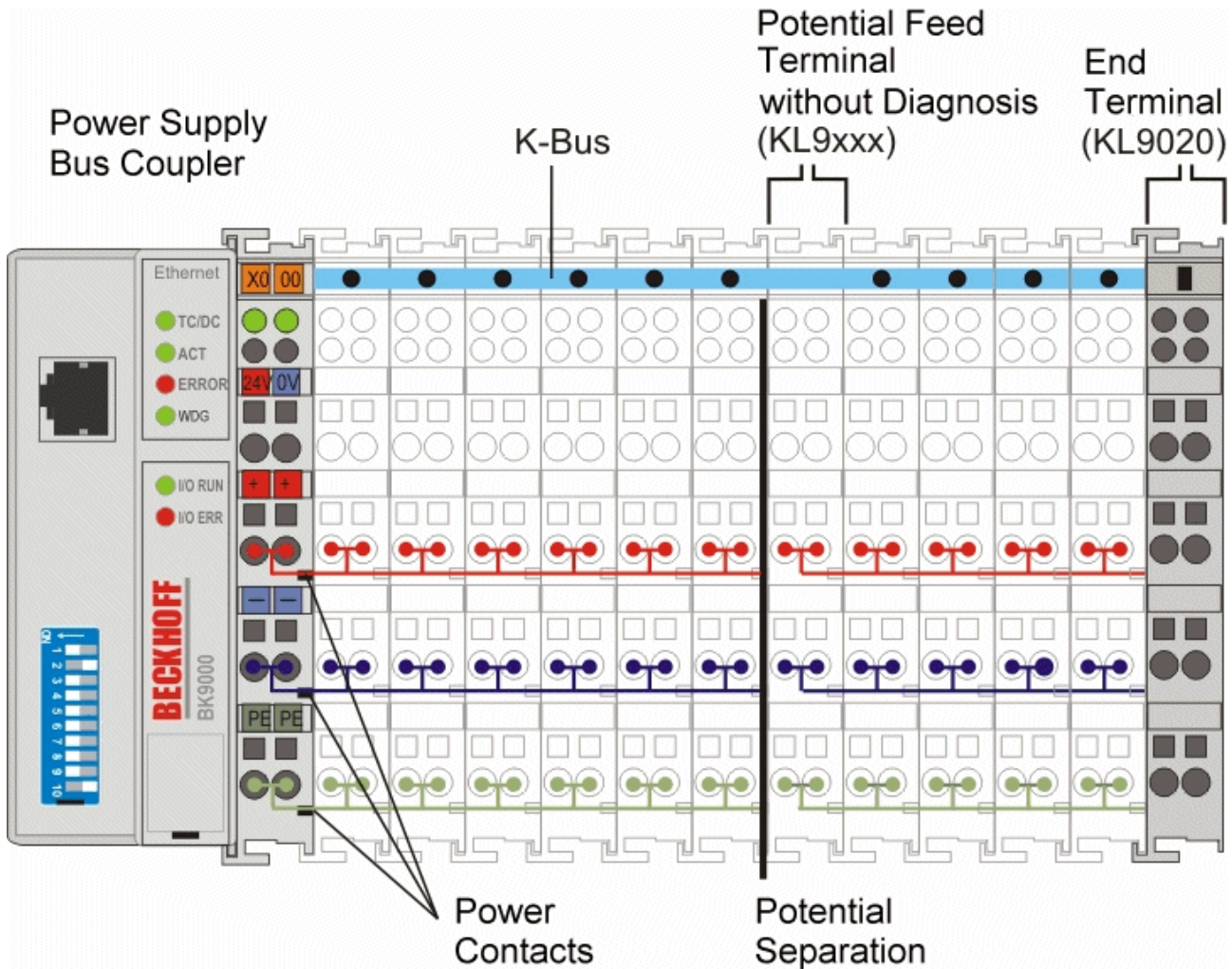

Fig. 3: The principle of the Bus Terminal

## 2.6 Ethernet

Ethernet was originally developed by DEC, Intel and XEROX (as the "DIX" standard) for passing data between office devices. The term nowadays generally refers to the *IEEE 802.3 CSMA/CD* specification, published in 1985. Because of the high acceptance around the world this technology is available everywhere and is very economical. This means that it is easy to make connections to existing networks.

There are now a number of quite different transmission media: coaxial cable (10Base5), optical fiber (10BaseF) or twisted pairs (10BaseT) with screen (STP) or without screen (UTP). Using Ethernet, different topologies can be built such as ring, line or star.

Ethernet transmits Ethernet packets from a sender to one or more receivers. This transmission takes place without acknowledgement, and without the repetition of lost packets. To achieve reliable data communication, there are protocols, such as TCP/IP, that can run on top of Ethernet.

## **Basic principles**

### **The Internet Protocol (IP)**

The internet protocol (IP) forms the basis of this data communication. IP transports data packets from one device to another; the devices can be in the same network, or in different networks. IP here looks after the address management (finding and assigning MAC-IDs), segmentation and routing. Like the Ethernet protocol, IP does not guarantee that the data is transported - data packets can be lost, or their sequence can be changed.

TCP/IP was developed to provide standardised, reliable data exchange between any numbers of different networks. TCP/IP was developed to provide standardised, reliable data exchange between any numbers of different networks. Although the term is often used as if it were a single concept, a number of protocols are layered together: e.g. IP, TCP, UDP, ARP and ICMP.

### **Transmission Control Protocol (TCP)**

The Transmission Control Protocol (TCP) which runs on top of IP is a connection-oriented transport protocol. It includes error detection and handling mechanisms. Lost telegrams are repeated.

### **User Datagram Protocol (UDP)**

UDP is connectionless transport protocol. It provides no control mechanism when exchanging data between sender and receiver. This results in a higher processing speed than, for example, TCP. Checking whether or not the telegram has arrived must be carried out by the higher-level protocol.

### **Internet Control Message Protocol (ICMP)**

It is used by end devices, to exchange information about the current status of the internet protocol.

### **Address Resolution Protocol (ARP)**

Performs conversion between the IP addresses and MAC addresses.

### **BootP**

The BootP protocol allows the TCP/IP address to be set or altered, by addressing the network device with its MAC-ID.

## 3 Mounting and wiring

### 3.1 Instructions for ESD protection

#### NOTE

##### **Destruction of the devices by electrostatic discharge possible!**

The devices contain components at risk from electrostatic discharge caused by improper handling.

- Please ensure you are electrostatically discharged and avoid touching the contacts of the device directly.
- Avoid contact with highly insulating materials (synthetic fibers, plastic film etc.).
- Surroundings (working place, packaging and personnel) should be grounded probably, when handling with the devices.
- Each assembly must be terminated at the right hand end with a KL9010 bus end terminal, to ensure the protection class and ESD protection.

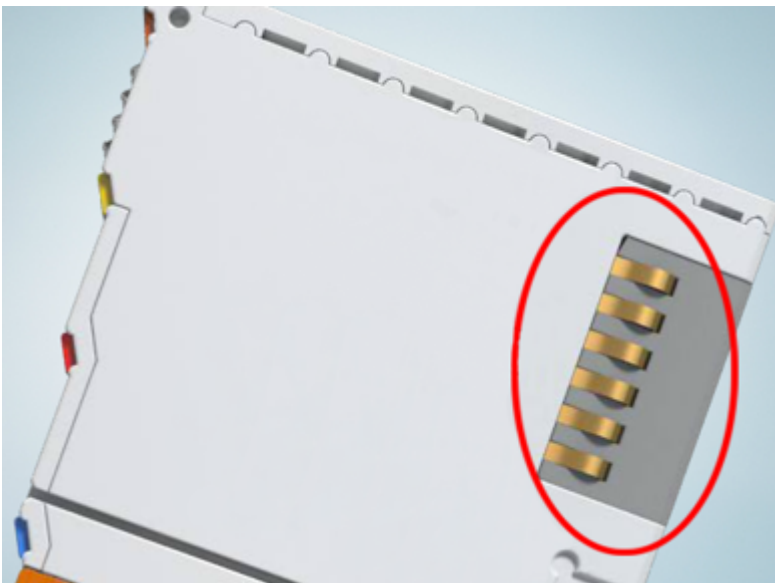

Fig. 4: Spring contacts of the Beckhoff I/O components

## 3.2 Mounting

### 3.2.1 Dimensions

The system of the Beckhoff Bus Terminals is characterized by low physical volume and high modularity. When planning a project it must be assumed that at least one Bus Coupler and a number of Bus Terminals will be used. The dimensions of the Bus Couplers are independent of the fieldbus system.

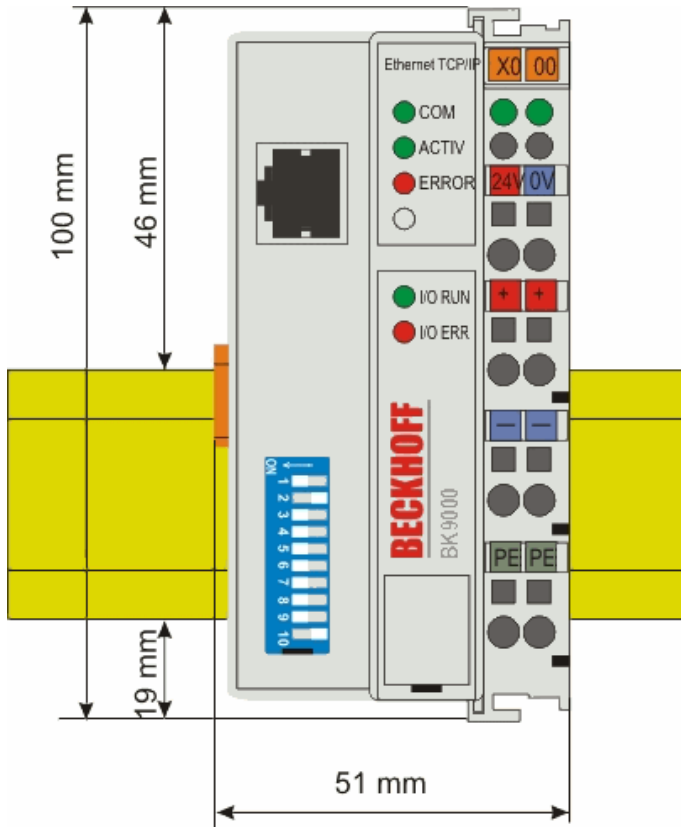

Fig. 5: BK9000, BK9100, BC9000, BC9020, BC9100, BC9120 - dimensions

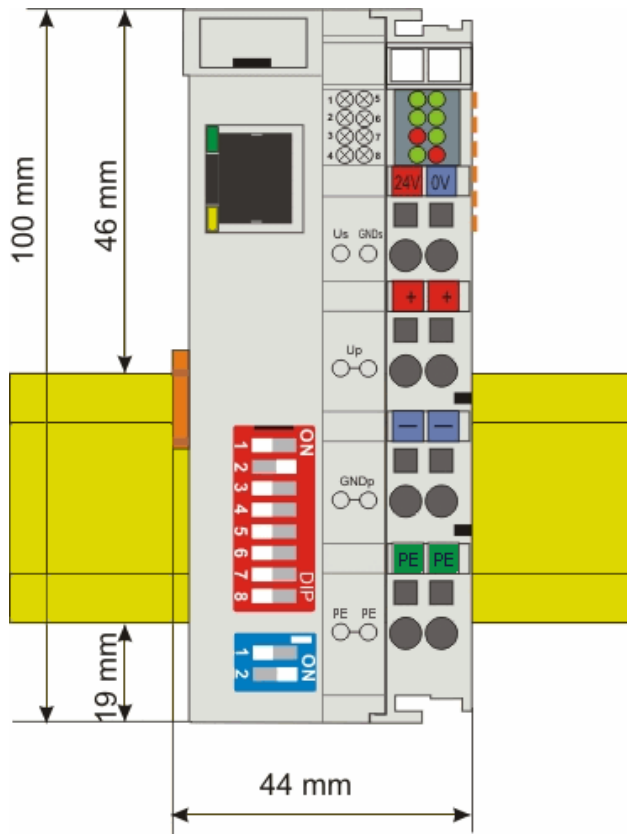

Fig. 6: BK9050, BC9050 - dimensions

The total width in practical cases is composed of the width of the Bus Coupler, the width of the bus terminals in use and the KL9010 Bus End Terminal. Depending on function, the Bus Terminals are 12 or 24 mm wide. The front wiring increases the total height of 68 mm by about 5 to 10 mm, depending on the wire thickness.

### 3.2.2 Installation on mounting rails

#### ⚠ WARNING

##### Risk of electric shock and damage of device!

Bring the bus terminal system into a safe, powered down state before starting installation, disassembly or wiring of the bus terminals!

#### Mounting

The Bus Couplers and Bus Terminals are attached to commercially available 35 mm mounting rails (DIN rail according to EN 60715) by applying slight pressure:

1. First attach the Fieldbus Coupler to the mounting rail.
2. The Bus Terminals are now attached on the right-hand side of the fieldbus Coupler. Join the components with slot and key and push the terminals against the mounting rail, until the lock clicks onto the mounting rail.  
If the terminals are clipped onto the mounting rail first and then pushed together without tongue and groove, the connection will not be operational! When correctly assembled, no significant gap should be visible between the housings.

#### ● Locking mechanism and fixing bolts

**i** The locking mechanism of the terminals and couplers extends to the profile of the mounting rail. At the installation, the locking mechanism of the components must not come into conflict with the fixing bolts of the mounting rail. To mount the mounting rails with a height of 7.5 mm under the terminals and couplers, you should use flat mounting connections (e.g. countersunk screws or blind rivets).

#### Disassembly

Each terminal is secured by a lock on the mounting rail, which must be released for disassembly:

1. Carefully pull the orange-colored lug approximately 1 cm out of the terminal to be disassembled, until it protrudes loosely. The lock with the mounting rail is now released for this terminal, and the terminal can be pulled from the mounting rail without excessive force.
2. Grasp the released terminal with thumb and index finger simultaneous at the upper and lower grooved housing surfaces and pull the terminal away from the mounting rail.

#### Connections within a Bus Terminal block

The electric connections between the Bus Coupler and the Bus Terminals are automatically realized by joining the components:

- The six spring contacts of the K-Bus/E-Bus deal with the transfer of the data and the supply of the Bus Terminal electronics.
- The power contacts deal with the supply for the field electronics and thus represent a supply rail within the Bus Terminal block. The power contacts are supplied via terminals on the Bus Coupler.

#### ● Power contacts

**i** During the design of a Bus Terminal block, the pin assignment of the individual Bus Terminals must be taken account of, since some types (e.g. analog Bus Terminals or digital 4-channel Bus Terminals) do not or not fully loop through the power contacts. Power Feed Terminals (KL91xx, KL92xx and EL91xx, EL92xx) interrupt the power contacts and thus represent the start of a new supply rail.

#### PE power contact

The power contact labelled PE can be used as a protective earth. For safety reasons this contact mates first when plugging together, and can ground short-circuit currents of up to 125 A.



**NOTE****Risk of damage to the device**

Note that, for reasons of electromagnetic compatibility, the PE contacts are capacitatively coupled to the mounting rail. This may lead to incorrect results during insulation testing or to damage on the terminal (e.g. disruptive discharge to the PE line during insulation testing of a consumer with a nominal voltage of 230 V). For insulation testing, disconnect the PE supply line at the Bus Coupler or the Power Feed Terminal! In order to decouple further feed points for testing, these Power Feed Terminals can be released and pulled at least 10 mm from the group of terminals.

**⚠ WARNING****Risk of electric shock!**

The PE power contact must not be used for other potentials!

**Wiring**

Up to eight connections enable the connection of solid or finely stranded cables to the Bus Terminals. The terminals are implemented in spring force technology. Connect the cables as follows:

1. Open a spring-loaded terminal by slightly pushing with a screwdriver or a rod into the square opening above the terminal.
2. The wire can now be inserted into the round terminal opening without any force.
3. The terminal closes automatically when the pressure is released, holding the wire safely and permanently.

**Shielding**

Analog sensors and actuators should always be connected with shielded, pair-wise twisted cables.

**3.3 Disposal**

Products marked with a crossed-out wheeled bin shall not be discarded with the normal waste stream. The device is considered as waste electrical and electronic equipment. The national regulations for the disposal of waste electrical and electronic equipment must be observed.

## 3.4 Wiring

### 3.4.1 Power supply, potential groups

#### WARNING

##### **Risk of electric shock and damage of device!**

Bring the bus terminal system into a safe, powered down state before starting installation, disassembly or wiring of the bus terminals!

#### **Power supply for the Bus Coupler**

The Bus Couplers require a 24 V<sub>DC</sub> supply for their operation. The connection is made by means of the upper spring-loaded terminals labelled 24 V and 0 V. The supply voltage feeds the Bus Coupler electronics and, over the K-Bus/E-Bus, the Bus Terminals. The power supply for the Bus Coupler electronics and that of the K-Bus/E-Bus are electrically separated from the potential of the field level.

#### **Power supply for the power contacts**

The bottom six connections with spring-loaded terminals can be used to feed the supply for the peripherals. The spring-loaded terminals are joined in pairs to a power contact. The feed for the power contacts has no connection to the voltage supply for the Bus Coupler. The design of the feed permits voltages of up to 24 V. The assignment in pairs and the electrical connection between feed terminal contacts allows the connection wires to be looped through to various terminal points. The current drawn from the power contacts must not exceed 10 A for long periods. The current carrying capacity between two spring-loaded terminals is identical to that of the connecting wires.

#### **Power contacts**

On the right hand face of the Bus Coupler there are three spring contacts for the power contact connections. The spring contacts are hidden in slots so that they cannot be accidentally touched. By attaching a Bus Terminal the blade contacts on the left hand side of the Bus Terminal are connected to the spring contacts. The tongue and groove guides on the top and bottom of the Bus Coupler and of the Bus Terminals guarantees that the power contacts mate securely.

#### **Configuration interface (not for BK1250, EK1x00)**

The standard Bus Couplers have an RS232 interface at the bottom of the front face. The miniature connector can be joined to a PC with the aid of a connecting cable and the KS2000 configuration software. The interface permits the Bus Terminals to be configured, for example adjusting the amplification factors of the analog channels. The interface can also be used to change the assignments of the bus terminal data to the process image in the Bus Coupler. The functionality of the configuration interface can also be reached via the fieldbus using string communication facility.

#### **Electrical isolation**

The bus couplers operate by means of three independent potential groups. The supply voltage feeds the K-Bus/E-Bus electronics in the Bus Coupler and the K-Bus/E-Bus itself in an electrically isolated manner. The supply voltage is also used to generate the operating voltage for the fieldbus.

Note: All Bus Terminals are electrically isolated from the K-Bus/E-bus. The K-Bus/E-bus is therefore completely electrically isolated.

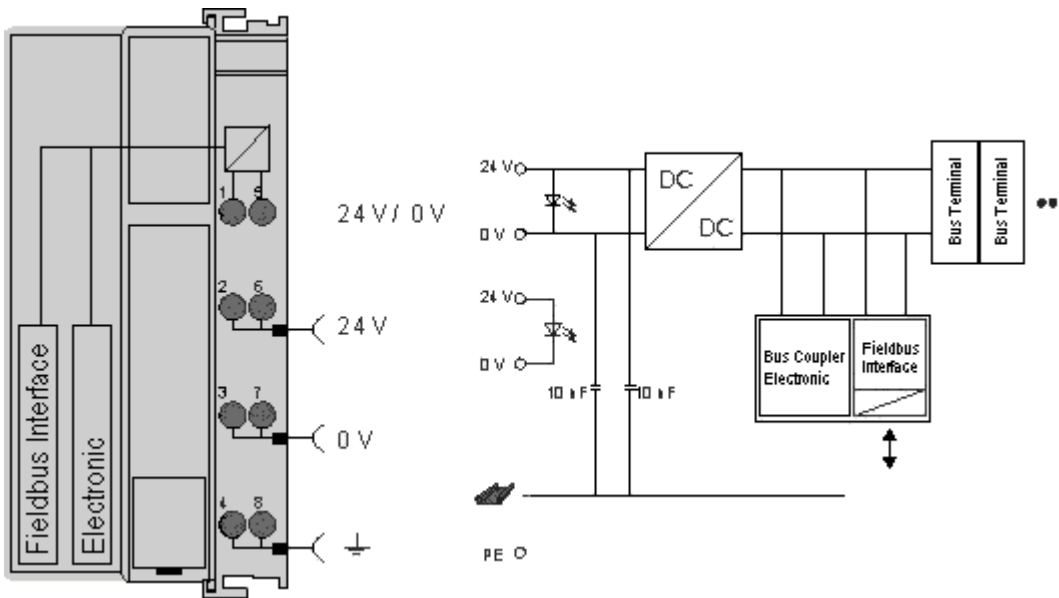

Fig. 7: Electrical isolation

### 3.4.2 Ethernet connection

The connection to Ethernet is made via an RJ45 connector (a Western plug).

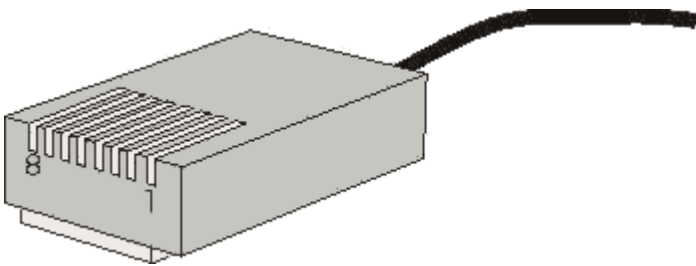

Fig. 8: RJ45 connector (Western plug)

#### Cabling

##### Connection via hub or switch

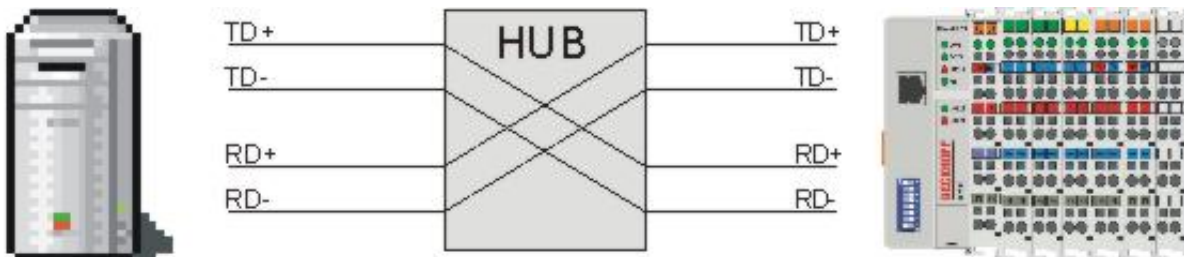

Fig. 9: Ethernet connection via hub or switch

Connect the PC's network card to the hub/switch using a standard Ethernet cable, and connect the hub, again using a standard Ethernet cable, to the Bus Terminal controller. Connection via a switch is done in the same way.

**Direct connection between PC with Ethernet card and BC9000**

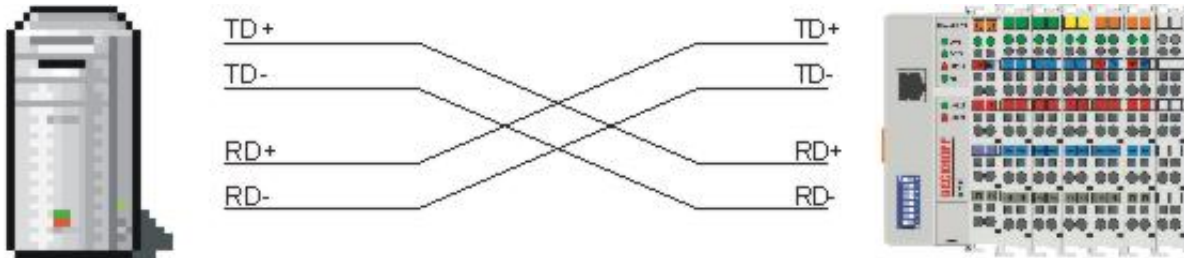

Fig. 10: Direct Ethernet connection (crossover cable)

Use a crossover Ethernet cable to connect the PC directly with the Bus Terminal Controller.

**Pin assignment of the RJ45 plug**

PIN	Signal	Description
1	TD +	Transmit +
2	TD -	Transmit -
3	RD +	Receive +
4	-	reserved
5	-	reserved
6	RD -	Receive -
7	-	reserved
8	-	reserved

**3.4.3 Ethernet topologies**

**BK9000, BK9050, BC9000, BC9020, BC9050**

These Bus Couplers and Bus Terminal controllers have a single Ethernet connection. This can be connected directly to an external switch. This makes it possible to construct the typical Ethernet star topology.

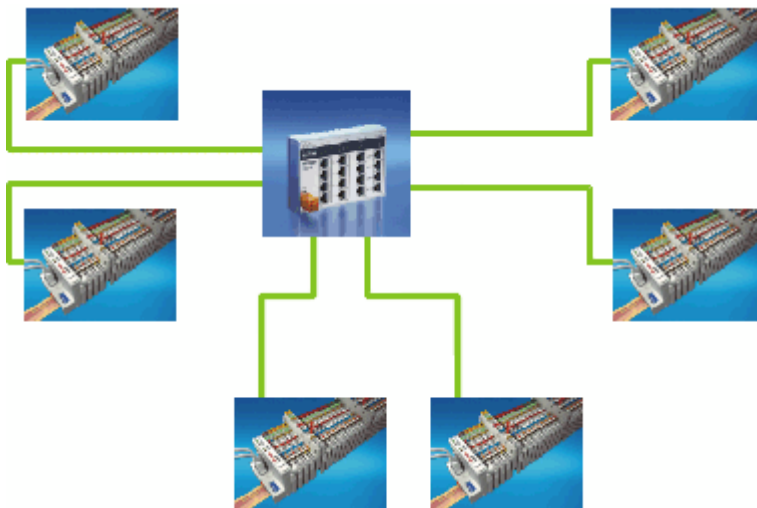

Fig. 11: Ethernet layout in star topology

**BK9100, BC9100, BC9120, BC9191**

These Bus Couplers and Bus Terminal controllers have an internal triple switch with one internal and two external ports. The internal switch enables the simple construction of a linear topology. A maximum of 20 BK9100/BC91x0/BC9191 can be connected in series in a physical line. However the distance between two Ethernet devices may not exceed 100 m. The maximum overall line length is therefore 2 km. No further switches may be included in this line.

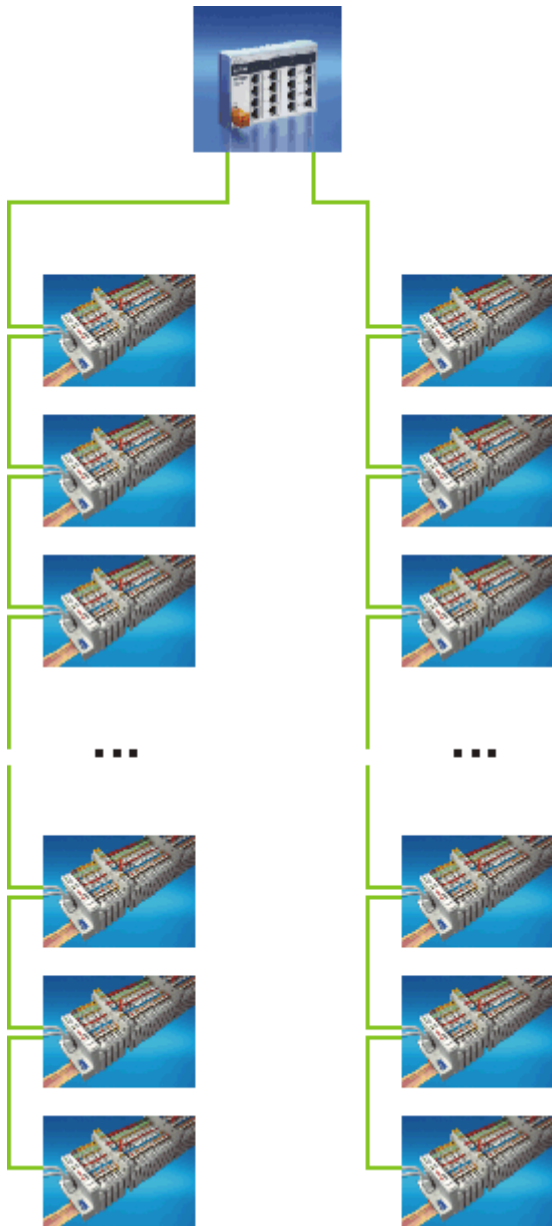

Fig. 12: Ethernet layout in linear topology

Of course, the construction of a classic star topology is also possible with these Bus Couplers and Bus Terminal controllers.

## 3.4.4 Ethernet cable

### Transmission standards

#### 10Base5

The transmission medium for 10Base5 consists of a thick coaxial cable ("yellow cable") with a max. transmission speed of 10 Mbaud arranged in a line topology with branches (drops) each of which is connected to one network device. Because all the devices are in this case connected to a common transmission medium, it is inevitable that collisions occur often in 10Base5.

#### 10Base2

10Base2 (Cheaper net) is a further development of 10Base5, and has the advantage that the coaxial cable is cheaper and, being more flexible, is easier to lay. It is possible for several devices to be connected to one 10Base2 cable. It is frequent for branches from a 10Base5 backbone to be implemented in 10Base2.

#### 10BaseT

Describes a twisted pair cable for 10 Mbaud. The network here is constructed as a star. It is no longer the case that every device is attached to the same medium. This means that a broken cable no longer results in failure of the entire network. The use of switches as star couplers enables collisions to be reduced. Using full-duplex connections they can even be entirely avoided.

#### 100BaseT

Twisted pair cable for 100 Mbaud. It is necessary to use a higher cable quality and to employ appropriate hubs or switches in order to achieve the higher data rate.

#### 10BaseF

The 10BaseF standard describes several optical fiber versions.

### Short description of the 10BaseT and 100BaseT cable types

Twisted-pair copper cable for star topologies, where the distance between two devices may not exceed 100 meters.

#### UTP

Unshielded twisted pair

This type of cable belongs to category 3, and is not recommended for use in an industrial environment.

#### S/UTP

Screened/unshielded twisted pair (screened with copper braid)

Has an overall shield of copper braid to reduce influence of external interference. This cable is recommended for use with Bus Couplers.

#### FTP

Foiled shielded twisted pair (screened with aluminium foil)

This cable has an outer screen of laminated aluminium and plastic foil.

#### S/FTP

Screened/foiled-shielded twisted pair (screened with copper braid and aluminium foil)

Has a laminated aluminium screen with a copper braid on top. Such cables can provide up to 70 dB reduction in interference power.



**STP**

Shielded twisted pair

Describes a cable with an outer screen, without defining the nature of the screen any more closely.

**S/STP**

Screened/shielded twisted pair (wires are individually screened)

This identification refers to a cable with a screen for each of the two wires as well as an outer shield.

**ITP**

Industrial Twisted-Pair

The structure is similar to that of S/STP, but, in contrast to S/STP, it has only one pair of conductors.

### 3.5 ATEX - Special conditions (standard temperature range)

#### ⚠ WARNING

**Observe the special conditions for the intended use of Beckhoff fieldbus components with standard temperature range in potentially explosive areas (directive 2014/34/EU)!**

- The certified components are to be installed in a suitable housing that guarantees a protection class of at least IP54 in accordance with EN 60079-15! The environmental conditions during use are thereby to be taken into account!
- For dust (only the fieldbus components of certificate no. KEMA 10ATEX0075 X Issue 9): The equipment shall be installed in a suitable enclosure providing a degree of protection of IP54 according to EN 60079-31 for group IIIA or IIIB and IP6X for group IIIC, taking into account the environmental conditions under which the equipment is used!
- If the temperatures during rated operation are higher than 70°C at the feed-in points of cables, lines or pipes, or higher than 80°C at the wire branching points, then cables must be selected whose temperature data correspond to the actual measured temperature values!
- Observe the permissible ambient temperature range of 0 to 55°C for the use of Beckhoff fieldbus components standard temperature range in potentially explosive areas!
- Measures must be taken to protect against the rated operating voltage being exceeded by more than 40% due to short-term interference voltages!
- The individual terminals may only be unplugged or removed from the Bus Terminal system if the supply voltage has been switched off or if a non-explosive atmosphere is ensured!
- The connections of the certified components may only be connected or disconnected if the supply voltage has been switched off or if a non-explosive atmosphere is ensured!
- The fuses of the KL92xx/EL92xx power feed terminals may only be exchanged if the supply voltage has been switched off or if a non-explosive atmosphere is ensured!
- Address selectors and ID switches may only be adjusted if the supply voltage has been switched off or if a non-explosive atmosphere is ensured!

#### Standards

The fundamental health and safety requirements are fulfilled by compliance with the following standards:

- EN 60079-0:2012+A11:2013
- EN 60079-15:2010
- EN 60079-31:2013 (only for certificate no. KEMA 10ATEX0075 X Issue 9)

#### Marking

The Beckhoff fieldbus components with standard temperature range certified according to the ATEX directive for potentially explosive areas bear one of the following markings:



**II 3G KEMA 10ATEX0075 X Ex nA IIC T4 Gc Ta: 0 ... +55°C**

II 3D KEMA 10ATEX0075 X Ex tc IIIC T135°C Dc Ta: 0 ... +55°C  
(only for fieldbus components of certificate no. KEMA 10ATEX0075 X Issue 9)

or



**II 3G KEMA 10ATEX0075 X Ex nA nC IIC T4 Gc Ta: 0 ... +55°C**

II 3D KEMA 10ATEX0075 X Ex tc IIIC T135°C Dc Ta: 0 ... +55°C  
(only for fieldbus components of certificate no. KEMA 10ATEX0075 X Issue 9)

### 3.6 ATEX - Special conditions (extended temperature range)

**⚠ WARNING**

**Observe the special conditions for the intended use of Beckhoff fieldbus components with extended temperature range (ET) in potentially explosive areas (directive 2014/34/EU)!**

- The certified components are to be installed in a suitable housing that guarantees a protection class of at least IP54 in accordance with EN 60079-15! The environmental conditions during use are thereby to be taken into account!
- For dust (only the fieldbus components of certificate no. KEMA 10ATEX0075 X Issue 9): The equipment shall be installed in a suitable enclosure providing a degree of protection of IP54 according to EN 60079-31 for group IIIA or IIIB and IP6X for group IIIC, taking into account the environmental conditions under which the equipment is used!
- If the temperatures during rated operation are higher than 70°C at the feed-in points of cables, lines or pipes, or higher than 80°C at the wire branching points, then cables must be selected whose temperature data correspond to the actual measured temperature values!
- Observe the permissible ambient temperature range of -25 to 60°C for the use of Beckhoff fieldbus components with extended temperature range (ET) in potentially explosive areas!
- Measures must be taken to protect against the rated operating voltage being exceeded by more than 40% due to short-term interference voltages!
- The individual terminals may only be unplugged or removed from the Bus Terminal system if the supply voltage has been switched off or if a non-explosive atmosphere is ensured!
- The connections of the certified components may only be connected or disconnected if the supply voltage has been switched off or if a non-explosive atmosphere is ensured!
- The fuses of the KL92xx/EL92xx power feed terminals may only be exchanged if the supply voltage has been switched off or if a non-explosive atmosphere is ensured!
- Address selectors and ID switches may only be adjusted if the supply voltage has been switched off or if a non-explosive atmosphere is ensured!

**Standards**

The fundamental health and safety requirements are fulfilled by compliance with the following standards:

- EN 60079-0:2012+A11:2013
- EN 60079-15:2010
- EN 60079-31:2013 (only for certificate no. KEMA 10ATEX0075 X Issue 9)

**Marking**

The Beckhoff fieldbus components with extended temperature range (ET) certified according to the ATEX directive for potentially explosive areas bear the following marking:



**II 3G KEMA 10ATEX0075 X Ex nA IIC T4 Gc Ta: -25 ... +60°C**  
 II 3D KEMA 10ATEX0075 X Ex tc IIIC T135°C Dc Ta: -25 ... +60°C  
 (only for fieldbus components of certificate no. KEMA 10ATEX0075 X Issue 9)

or



**II 3G KEMA 10ATEX0075 X Ex nA nC IIC T4 Gc Ta: -25 ... +60°C**  
 II 3D KEMA 10ATEX0075 X Ex tc IIIC T135°C Dc Ta: -25 ... +60°C  
 (only for fieldbus components of certificate no. KEMA 10ATEX0075 X Issue 9)

### 3.7 Continulative documentation for ATEX and IECEx

#### NOTE



#### **Continulative documentation about explosion protection according to ATEX and IECEx**

Pay also attention to the continuative documentation

#### **Ex. Protection for Terminal Systems**

Notes on the use of the Beckhoff terminal systems in hazardous areas according to ATEX and IECEx,

that is available for [download](#) within the download area of your product on the Beckhoff homepage [www.beckhoff.com](http://www.beckhoff.com)!

## 4 Parameterization and commissioning

### 4.1 Start-up behaviour of the Bus Coupler

Immediately after being switched on, the Bus Coupler checks, in the course of a self-test, all the functions of its components and the communication on the K-bus/E-bus. The red I/O LED blinks while this is happening. After completion of the self-test, the Bus Coupler starts to test the attached Bus Terminals (the "Bus Terminal Test"), and reads in the configuration. The Bus Terminal configuration is used to generate an internal structure list, which is not accessible from outside. In case of an error, the Bus Coupler enters the *Stop* state. Once the start-up has completed without error, the Bus Coupler enters the *fieldbus start* state.

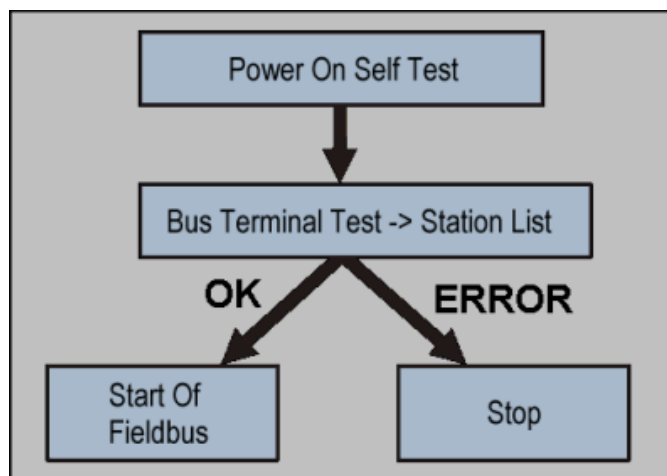

Fig. 13: Start-up behaviour of the Bus Coupler

The Bus Coupler can be made to enter the normal operating state by switching it on again once the fault has been rectified.

## 4.2 Parameterization of the Bus Coupler using DIP switches

The following parameterizations can be carried out without using configuration software, with the aid of the DIP switches and the end terminal (KL9010).

This paramétrisation mode is only active if only one end terminal (KL9010) is inserted. Otherwise, the normal settings apply.

### Restoring the manufacturer's settings

- Switch the Bus Coupler off and then append the end terminal (KL9010).
- Set all the DIP switches to ON, and switch the Bus Coupler on again.
- Once the default parameters have successfully been set, the *Error* LED lights, and the *I/O RUN* and *I/O ERR* LEDs flash alternately.
- You can then switch the Bus Coupler off, connect the Bus Terminals, and continue as usual.

### Deleting the boot project (BC9000 only)

- Switch the Bus Coupler off and then append the end terminal (KL9010).
- Set DIP switches 1 to 9 to ON, DIP switch 10 to OFF, and switch the Bus Coupler on again.
- Once the boot project has been successfully deleted, the *I/O RUN* and *I/O ERR* LEDs flash alternately.
- You can then switch the Bus Coupler off, connect the Bus Terminals, and continue as usual.

### Setting the Ethernet parameters

- Switch the Bus Coupler off and then append the end terminal (KL9010).
- Set all the DIP switches to OFF, and switch the Bus Coupler on again.
- The *I/O RUN* and *I/O ERR* LEDs light steadily.
- Make the desired setting in accordance with the following table.

DIP switch	Parameter	Selection	Setting	Comment
1	Baud rate	10 MBaud	OFF (0)	
		100 MBaud	ON (1)	Default
2	Auto-Baud-Rate	Disable	OFF (0)	
		Enable	ON (1)	Default
3	Transmission type	Half duplex	OFF (0)	
		Full duplex	ON (1)	Default

- To accept the values, set DIP switch 10 to ON.  
By flashing the *I/O RUN* and *I/O ERR* LEDs the Bus Coupler indicates that it has accepted the parameters.
- You can then switch the Bus Coupler off, connect the Bus Terminals, and continue as usual.

### 4.3 Network classes

Three different network classes are distinguished. They determine how many address bits are reserved for the network ID and how many for the node number (e.g. for PCs or Bus Couplers). The difference is located in the first three bits of the IP address.

Network class	Number of bits for the network ID	Enables no. of networks	No. of bits for the node address	Enables no. of nodes per network
A	7	126	24	16 777 214
B	14	16 382	16	65 536
C	21	2 097 150	8	254

**● Unique IP address**

**i** An IP address must be unique within the entire connected network!

**Network class A, Addresses: 1.xxx.xxx.xxx - 126.xxx.xxx.xxx**

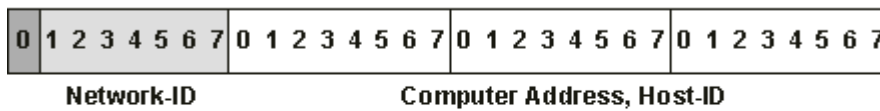

**Network class B, Addresses: 128.0.xxx.xxx - 191.255.xxx.xxx**

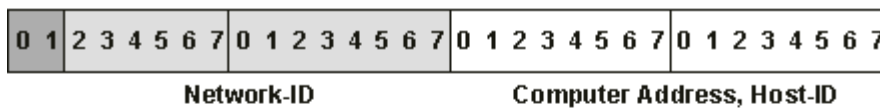

**Network class C, Addresses: 192.0.0.xxx - 223.255.255.xxx**

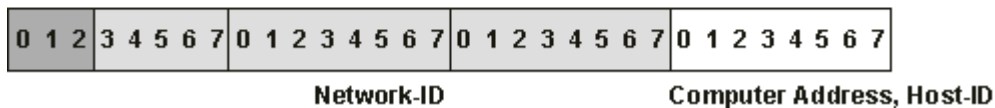

Fig. 14: Network classes

**● Identical network class**

**i** In a communication with another Ethernet devices, the IP address set must have the same network class. Sample: Your PC has the address 172.16.17.55, which means the coupler must have the address 172.16.xxx.xxx (xxx stands for a number between 0 and 255. 0 is usually used by the router/switch and should therefore remain reserved).

In order to see the PC's own address, the command *ipconfig* can be entered into a DOS window under Windows NT/2000/XP.



## 4.4 IP address

### 4.4.1 IP address

The IP address can be set using four different procedures, and these will be described in more detail below.

Procedure	Explanation	Necessary components
KS2000	Addressing using the KS2000 configuration software and DIP switches [▶ 34]	KS2000 configuration software and KS2000 cable
ARP	Addressing via the ARP table [▶ 35]	PC with network
BootP	Addressing via BootP server [▶ 36]	BootP server
DHCP	Addressing via DHCP server	DHCP server

### 4.4.2 Configuration with KS2000

The KS2000 configuration software (from version 3.2.8) can be used to set the TCP/IP address in a dialog box, or it can be written directly into the registers. DIP switches 9 and 10 (for BK9050 DIP switches 1 and 2 in blue) should both be OFF (0) before switching on.

**Table 100**

Register	High byte	Low byte
0	IP-Byte 2	IP-Byte 1
1	Not used	IP-Byte 3

#### Default

Byte	Default value (hex)	Default value (dec)
1	0xAC	172 <sub>dec</sub>
2	0x10	16 <sub>dec</sub>
3	0x11	17 <sub>dez</sub>
4	(DIP switch)	(0 to 255 <sub>dec</sub> )

#### Sample



Fig. 15: BK9000, BK9100, BC9000, BC9100



Fig. 16: BK9050

Switch no.	1	2	3	4	5	6	7	8	9 (1)	10 (2)	
Valence	1	2	4	8	16	32	64	128	-	-	
In this example	ON	OFF	OFF	ON	OFF	OFF	ON	ON	OFF	OFF	
Value	1	0	0	8	0	0	64	128	-	-	Total=201

---

### ● Software reset



A software reset of the BK9500 is required in order to save changes in the tables of a BK9000. A hardware reset (power on/off) is not sufficient!

---

## 4.4.3 Setting the IP address using the ARP table

An easy method of modifying the IP address is to set the address using the DOS window. It is, however, only possible to alter addresses within the same network class. The new IP address that has been set remains stored even after the Bus Coupler has been switched off.

### Procedure

- Set DIP switches 9 and 10 to OFF. DIP switches 1-8 then no longer have any address function.
- Open a DOS box on your PC.
- Enter the command "ping <OLD IP address>" to create an entry in the ARP table.
- Read the table with the command "ARP -a".
- Enter "ARP -d <OLD IP address>" to remove the Bus Coupler from the table.
- Use "ARP -s <NEW IP address> <MAC-ID [[▶ 38](#)]>" to make an entry manually.
- With "ping -l 123 <NEW IP address>" the new IP address becomes valid.

A short flash from the ERROR LED at the moment of switching on indicates that the Bus Coupler is being addressed by ARP, and that DIP switches 1-8 give no indication of the address that is set.

---

### ● Changing the IP address



If the IP address is changed, all dynamic ARP entries must be deleted. Only one ping with a length of 123 bytes is permitted for the reconfiguration of the IP address (>ping -l "IP-Address<").

---

### Sample

1. C:>ping 172.16.17.255
2. C:>ARP -a  
172.16.17.255 00-01-05-00-11-22
3. C:>arp -d 172.16.17.255
4. C:>arp -s 172.16.44.44 00-01-05-00-11-22
5. C:>ping -l 123 172.16.44.44

#### 4.4.4 Setting the IP Address Using the Beckhoff BootP Server

If the address is to be set by the Beckhoff BootP server, then set DIP switch 9 to ON (1) and DIP switch 10 to OFF (0). DIP switches 1-8 then no longer have any address function. If this is not the case, the Bus Coupler reports LED error code 6-4 (see diagnostics LEDs). The *TCP/IP ERROR LED* flashes while the address is being allocated.

##### IP address save modes

##### DIP switches 1-8 in the ON position

The address assigned by the BootP server is stored, and the BootP service will not be restarted after the next cold start.

The address can be cleared again by reactivating the manufacturers' settings (using the KS2000 software or by [DIP switch and end terminal](#) [▶ 32]).

##### DIP switches 1-8 in the OFF position

The IP address assigned by the BootP server is only valid until the Bus Coupler is switched off. The BootP server must assign a new IP address to the Bus Coupler at the next cold start.

The address is, however, retained through a software reset of the Bus Coupler.

##### Beckhoff BootP server

Beckhoff supply a BootP server for Windows 98, ME, NT4.0, NT2000 and XP. The installation version of the Beckhoff TwinCAT CD can be found under the folder >Unsupported Utilities< or under [https://download.beckhoff.com/download/software/TwinCAT/TwinCAT2/Unsupported Utilities/TcBootP\\_Server/](https://download.beckhoff.com/download/software/TwinCAT/TwinCAT2/Unsupported%20Utilities/TcBootP_Server/)

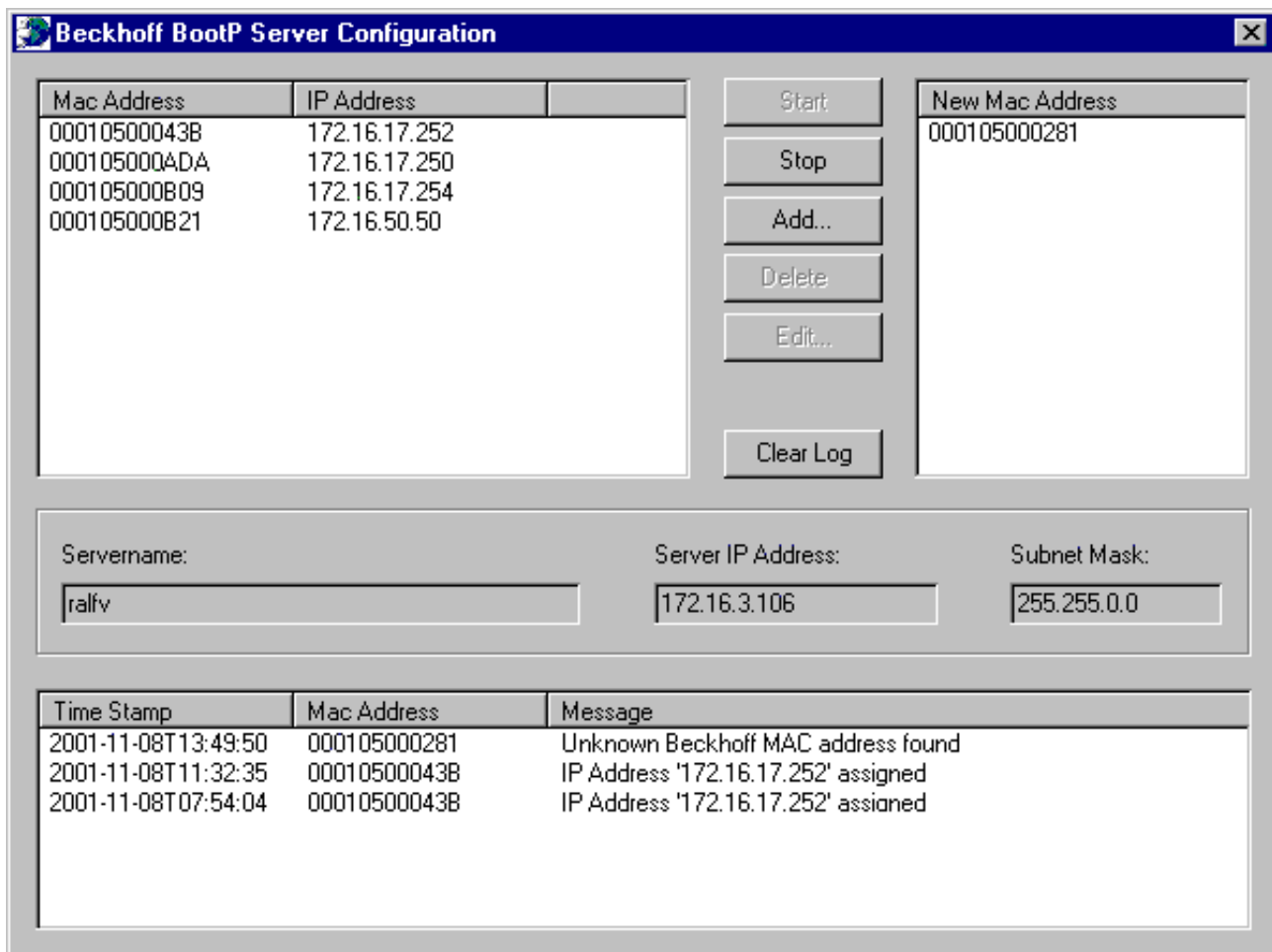

Fig. 17: Configuration of the Beckhoff BootP server

As soon as the BootP server has started, the *New MAC Address* window shows all the Beckhoff nodes that are working in BootP mode and still have not received an IP address. The assignment of the [MAC-ID \[▶ 38\]](#) to IP address is made with the "<<" button. Successful assignment is displayed in the log window. To start the BootP server automatically when your PC boots, it is only necessary to provide a shortcut in the Windows autostart folder. Include the */Start* parameter in the shortcut (.../TcBootPDlg.exe/start).

### 4.4.5 Setting the address using a DHCP server

To set the address by means of a DHCP server, set DIP switch 9 to OFF (0) and DIP switch 10 to ON (1).

In this state the DHCP service is switched on, and the Bus Coupler is assigned an IP address by the DHCP server.

The DHCP server must know the MAC ID of the Bus Coupler and should assign the same IP address to this MAC ID on each startup.

The *TCP/IP error* LED flashes while the address is being allocated.

### 4.4.6 Subnet mask

The subnet mask is subject to the control of the network administrator, and specifies the structure of the subnet.

Small networks without a router do not require a subnet mask. The same is true if you do not use registered IP numbers. A subnet mask can be used to subdivide the network with the aid of the mask instead of using a large number of network numbers.

The subnet mask is a 32-bit number:

- Ones in the mask indicate the subnet part of an address space.
- Zeros indicate that part of the address space which is available for the host IDs.

Description	Binary representation	Decimal representation
IP address	10101100.00010000.00010001.11001000	172.16.17.200
Subnet mask	11111111.11111111.00010100.00000000	255.255.20.0
Network ID	10101100.00010000.00010000.00000000	172.16.16.0
Host ID	00000000.00000000.00000001.11001000	0.0.1.200

#### Standard subnet mask

Address class	Standard subnet mask (decimal)	Standard subnet mask (hex)
A	255.0.0.0	FF.00.00.00
B	255.255.0.0	FF.FF.00.00
C	255.255.255.0	FF.FF.FF.00

#### **i** Subnets and host number

Neither subnet 0 nor the subnet consisting only of ones may be used. Neither host number 0 nor the host number consisting only of ones may be used!

If the IP address is set using the KS2000 configuration software, it is necessary for the subnet mask also to be changed with the KS2000 configuration software.

If ARP addressing is used, the associated standard subnet mask, based on the IP address, is entered.

Under BootP or DHCP the subnet mask is transmitted also by the server.

## 4.4.7 Testing the IP address

To test the IP address you can use the *Ping* command in a Windows prompt.

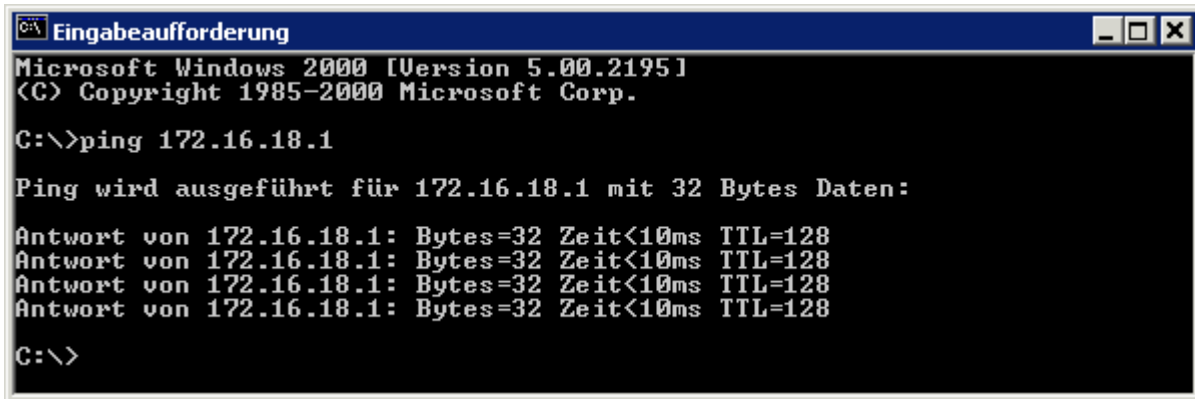

```
Microsoft Windows [Version 5.00.2195]
(C) Copyright 1985-2000 Microsoft Corp.

C:\>ping 172.16.18.1

Ping wird ausgeführt für 172.16.18.1 mit 32 Bytes Daten:

Antwort von 172.16.18.1: Bytes=32 Zeit<10ms TTL=128
Antwort von 172.16.18.1: Bytes=32 Zeit<10ms TTL=128
Antwort von 172.16.18.1: Bytes=32 Zeit<10ms TTL=128
Antwort von 172.16.18.1: Bytes=32 Zeit<10ms TTL=128

C:\>
```

Fig. 18: Testing the IP address using the Ping command

## 4.4.8 Reading the MAC-ID

Proceed as follows to read the MAC-ID.

- Change the IP address of your PC to 172.16.x.x. and the subnet mask to 255.255.0.0  
In the delivery condition of the BC9000 or BK9000, the IP address is 172.16.17.255 (DIP switches 1 to 8 set to ON).
- Start the DOS window
- Send a *ping >ip-address<* to the IP address 172.16.17.255
- Read the MAC-ID with *arp -a*.

# 5 Configuration

## 5.1 ModbusTCP

### 5.1.1 ModbusTCP Process Image

The ModbusTCP process image makes a fundamental distinction between digital and byte-oriented and word-oriented signals (Bus Terminals). Additionally, a distinction is made between inputs and outputs. The [mapping table \[▶ 40\]](#) shows which Bus Terminals belong to which mapping.

Digital inputs	Digital outputs
Offset 0 ... 4095 Modbus function Reading 2 Writing: -	Offset 0 ... 4095 Modbus function Reading 1 Writing 5, 15
Analog/digital inputs	Analog/digital outputs
Offset 0x000 ... 0x0FF Modbus function Reading 3, 23 Writing: -	Offset 0x800 ... 0x8FF Modbus function Reading 3, 4, 23 Reading 3, 4, 23

This will be clarified by examples.

#### Sample 1

- 1 x BK9000
- 4 x KL1xx4
- 2 x KL2xx2
- 1 x KL9010

Inputs			Outputs		
Modbus func-tion	Modbus ad-dress/offset	Bus Termi-nal	Modbus func-tion	Modbus address/offset	Bus Termi-nal
3 read	0x0000	4 x KL1xx4	3 read	0x0800	2 x KL2xx2
4 read	0x0000		1 read	0x0000	
2 read	0x0000 - 0x000F		5 write	0x0000-0x0003	
		15 write	0x0000-0x0003		
		6 write	0x800		
		16 write	0x800		
		23 write	0x800		

#### Sample 2

- 1 x BK9000
- 4 x KL1xx4
- 2 x KL2xx2
- 1 x KL1501
- 1 x KL3xx2
- 1 x KL4xx2
- 1 x KL9010

Inputs			Outputs		
Modbus function	Modbus address/offset	Bus Terminal	Modbus function	Modbus address/offset	Bus Terminal
3, 4 read	0x0000..0002	KL1501	3 read	0x0800..0802	KL1501
			6, 16 write	0x0800..0802	
3, 4 read	0x0003..0x0006	KL3xx2	3 read	0x0803..0x0806	KL3xx2
			6, 16 write	0x0803..0x0806	
3, 4 read	0x0007..0x000A	KL4xx2	3 read	0x0807..0x080A	KL4xx2
			6, 16 write	0x0807..0x080A	
3 read	0x000B	4 x KL1xx4	3 read	0x080B	2 x KL2xx2
			4 read	0x080B	
4 read	0x000B		1 read	0x0000-0x0003	
2 read	0x0000 - 0x000F		5 write	0x0000-0x0003	
			15 write	0x0000-0x0003	
			6 write	0x80B	
			16 write	0x80B	
			23 write	0x80B	

## 5.2 Mapping the Bus Terminals

The precise assignment of the byte-oriented Bus Terminals may be found in the configuration guide for the particular bus terminal. This documentation is available on the Beckhoff *Products & Solutions* CD or on the Internet under <http://www.beckhoff.de>.

Byte oriented Bus Terminals	Bit oriented Bus Terminals
KL15x1	KL10xx, KL11xx, KL12xx, KL17xx, KM1xxx
KL25xx	KL20xx, KL21xx, KL22xx, KL26xx, KL27xx, KM2xxx
KL3xxx	
KL4xxx	
KL5xxx	
KL6xxx	
KL7xxx	
KL8xxx	
	KL9110, KL9160, KL9210, KL9260

## 5.3 TwinCAT System Manager

### 5.3.1 Configuration using the System Manager

Enter a general Ethernet card in the TwinCAT System Manager under devices. If the Bus Couplers are already connected to the network and have IP addresses, you can also read these. This will cause all the Bus Couplers with Bus Terminals and their configurations to be loaded. You can then adapt these to meet your requirements.



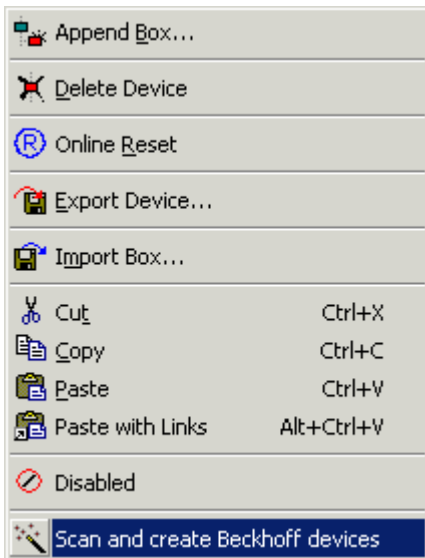

Fig. 19: Reading the connected Bus Couplers and Bus Terminals

**Commissioning with 6 or more Ethernet nodes**

If you enter more than five nodes in the System Manager, you will have to increase the router memory. You will find this setting in the System Manager under *Real Time Settings*. Enter 350 kB there for each Bus Coupler. This will give, for instance, 3.5 MB (10 x 350 kB) for 10 Bus Couplers.

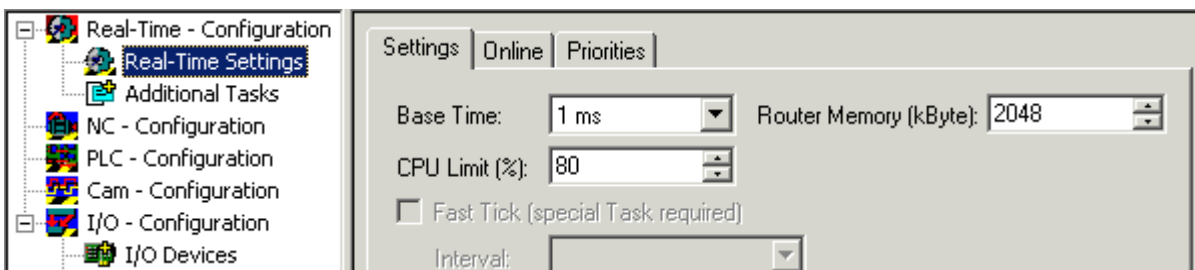

Fig. 20: Setting the router memory

Note: The router memory depends on your PC's main memory, and there is a limit to how high it can be set. Calculation of the maximum possible router memory:  
 max. router memory [MB] = (1 MB + ((RAM [MB] - 4 MB) x 0.4))

**Sample**

Suppose your PC has 128 MB of RAM:  
 1 MB + (128 MB - 4 MB) x 0.4 = 50.6 MB  
 So the maximum size of the router memory must not exceed 50.6 MB if there is 128 MB of RAM.

## 5.3.2 ADS Process Image

The process image of the Bus Terminals is sub-divided into input image and output image. The Bus Coupler first maps all complex (byte-oriented) Bus Terminals into the process image in the order in which they are inserted, and only at the end attaches the digital Bus Terminals to the process image.

The complex (byte-oriented) Bus Terminals are mapped as follows:

- Complete evaluation
- Word alignment
- Intel format

### Sample 1

BK9000  
4 x KL1xx4  
2 x KL2xx2  
1 x KL9010

Pos.	Bus Terminal	Input %I..	Output %Q..
1	KL1xx4	0.0 ... 0.3	-
2	KL1xx4	0.4 ... 0.7	-
3	KL1xx4	1.0 ... 1.3	-
4	KL1xx4	1.4 ... 1.7	-
5	KL2xx2	-	0.0 ... 0.1
6	KL2xx2	-	0.2 ... 0.3
9	KL6010	-	-

### Sample 2

BK9000  
4 x KL1xx4  
2 x KL2xx2  
1 x KL1501  
1 x KL3xx2  
1 x KL4xx2  
1 x KL9010

Pos.	Bus Terminal	Input %I..	Output %Q..
1	KL1501	0..5	0..5
2	KL3xx2	6..13	6..13
3	KL4xx2	14..21	14..21
4	KL1xx4	22.0..22.3	-
5	KL1xx4	22.4..22.7	-
6	KL1xx4	23.0..23.3	-
7	KL1xx4	23.4..23.7	-
8	KL2xx2	-	22.0...22.1
9	KL2xx2	-	22.2...22.3
10	KL6010	-	-

### 5.3.3 The IP Address tab

Ethernet components require an unambiguous IP address in the network. The setting dialog necessary for configuration of the fieldbus nodes in the TwinCAT system is described below. The tab illustrated appears after you have selected a BK9000, BC9000 or other Ethernet fieldbus device with the right mouse button (Add box) under your Ethernet cards in the System Manager.

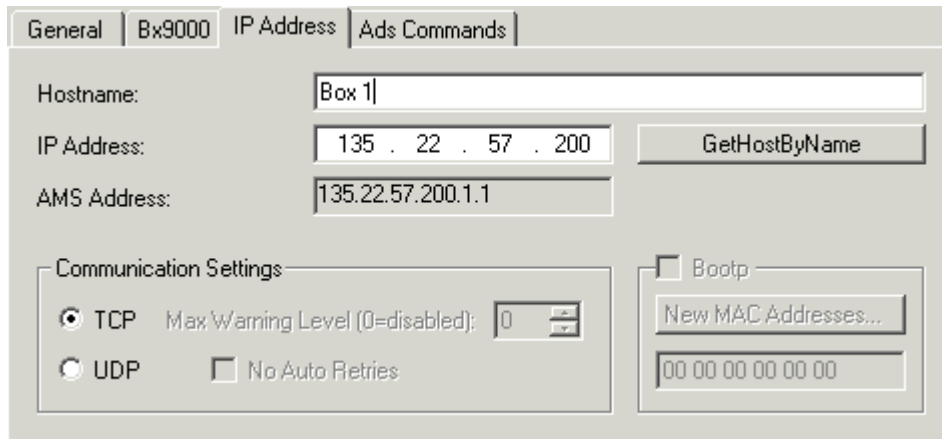

Fig. 21: The IP Address tab

#### Host name

The name of the Bus Coupler station can be edited here.

#### IP address

Enter the IP address of the Bus Coupler here.

#### GetHostByName

By clicking this button you can (as from BK9000 firmware version *B2*) obtain an IP address from a Windows 2000 DHCP (Dynamic Host Configuration Protocol) server.

#### AMS Address

Reports the Bus Coupler's AMS Net ID. It is automatically generated from the IP address by adding two additional bytes (e.g. ".1.1").

#### BootP

This checkbox can be activated if the Beckhoff BootP server has been installed and started (as from TwinCAT Version 2.8).

#### New MAC Addresses

If the [Beckhoff BootP server \[► 36\]](#) has been started, the MAC addresses (Media Access Controller) of Ethernet fieldbus devices that have newly been connected can be displayed by clicking this button. If only one new Ethernet fieldbus device has been connected, then only one new MAC address will accordingly be displayed. You can then assign it to the desired IP address in the *IP address* field described above. Each time another Ethernet fieldbus component is added you can repeat this process on the tab described here for the new device.

#### Communication Settings

Settings for IP (Internet Protocol) communication.

## TCP

If this option is active (which is the default) the communication is handled by TCP (*Transmission Control Protocol*). This means that telegram packets to and from Bus Couplers are exchanged using a reliable (acknowledged) mechanism.

## UDP

If this option is selected, communication is handled by UDP (*User Datagram Protocol*). In contrast to TCP, the individual telegram packets are not exchanged using a reliable mechanism. They are, in other words, not individually acknowledged by the receiver after they have arrived. Telegram packets that are damaged or whose sequence has become disturbed are neither re-sent nor sorted. The advantage of UDP is that the telegram transfer times can be calculated, because it is not necessary to wait for an answer from the receiver. It is therefore possible to talk of UDP in terms of a limited real-time capability.

## Max. Warning Level

This setting option is only active with *UDP*. The maximum value of the error counter can be entered here. Waiting for response telegrams from the fieldbus node stops when the set maximum value has been reached. Instead, read telegrams only, based on a higher cycle time, are sent to the fieldbus nodes.

## No Auto Retries

This checkbox also can only be selected when the *UDP* option is active. If this checkbox is active, then when the level set under *Max. Warning Level* has been reached it will be necessary to execute the *IO/Reset* function. No outputs will be output as long as no reset has been triggered.

## 6 Fieldbus system

### 6.1 Ethernet

Ethernet was originally developed by DEC, Intel and XEROX (as the "DIX" standard) for passing data between office devices. The term nowadays generally refers to the *IEEE 802.3 CSMA/CD* specification, published in 1985. Because of the high acceptance around the world this technology is available everywhere and is very economical. This means that it is easy to make connections to existing networks.

There are now a number of quite different transmission media: coaxial cable (10Base5), optical fiber (10BaseF) or twisted pairs (10BaseT) with screen (STP) or without screen (UTP). Coaxial cable (10Base5), optical fiber (10BaseF) or twisted pairs (10BaseT) with screen (STP) or without screen (UTP).

Ethernet transmits Ethernet packets from a sender to one or more receivers. This transmission takes place without acknowledgement, and without the repetition of lost packets. To achieve reliable data communication, there are protocols, such as TCP/IP, that can run on top of Ethernet.

#### MAC-ID

The sender and receiver of Ethernet packets are addressed by means of the MAC-ID. The MAC-ID is a 6 byte identification code unique to every Ethernet device in the world. The MAC-ID consists of two parts. The first part (i.e. the first 3 bytes) is a manufacturer identifier. The identifier for Beckhoff is 00 01 05. The next 3 bytes are assigned by the manufacturer and implement a unique serial number. The MAC-ID can, for example, be used for the BootP protocol in order to set the TCP/IP number. This involves sending a telegram containing the information such as the name or the TCP/IP number to the corresponding node. You can read the MAC-ID with the KS2000 configuration software.

#### The Internet Protocol (IP)

The internet protocol (IP) forms the basis of this data communication. IP transports data packets from one device to another; the devices can be in the same network, or in different networks. IP here looks after the address management (finding and assigning MAC-IDs), segmentation and routing. Like the Ethernet protocol, IP does not guarantee that the data is transported - data packets can be lost, or their sequence can be changed.

TCP/IP was developed to provide standardized, reliable data exchange between any numbers of different networks. TCP/IP was developed to provide standardized, reliable data exchange between any numbers of different networks. Although the term is often used as if it were a single concept, a number of protocols are layered together: z. B. IP, TCP, UDP, ARP and ICMP.

#### Transmission Control Protocol (TCP)

The Transmission Control Protocol (TCP) which runs on top of IP is a connection-oriented transport protocol. It includes error detection and handling mechanisms. Lost telegrams are repeated.

#### User Datagram Protocol (UDP)

UDP is connectionless transport protocol. It provides no control mechanism when exchanging data between sender and receiver. This results in a higher processing speed than, for example, TCP. Checking whether or not the telegram has arrived must be carried out by the higher-level protocol.

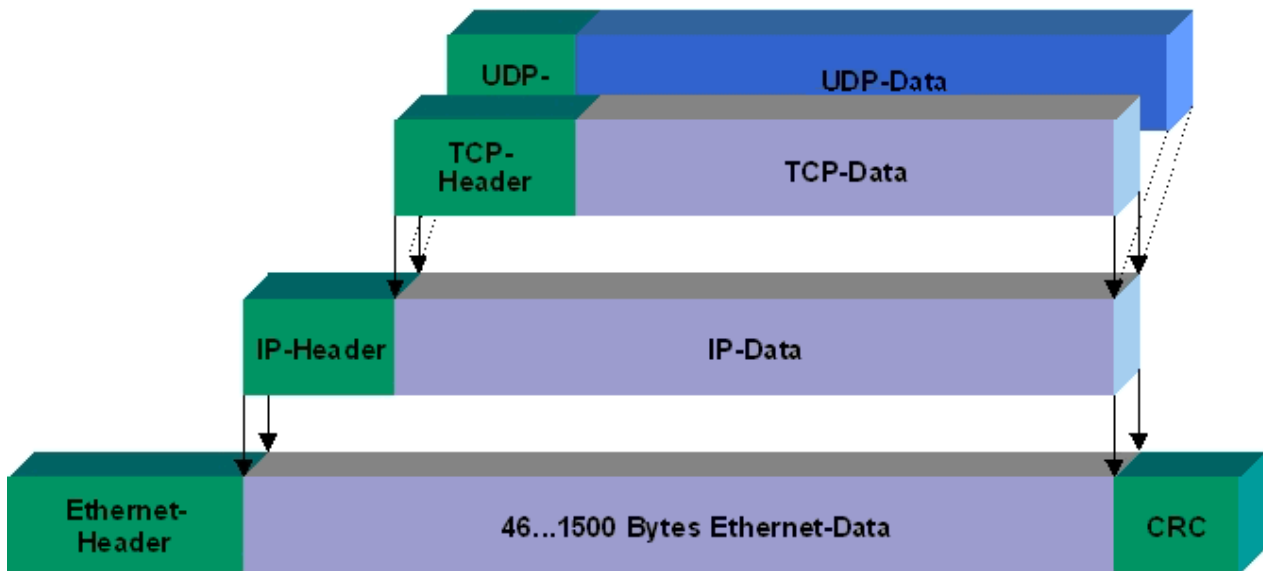

Fig. 22: User Datagram Protocol (UDP)

**Protocols running on top of TCP/IP and UDP/IP**

The following protocols can run on top of TCP/IP or UDP:

- ADS
- ModbusTCP

Both of these protocols are implemented in parallel on the Bus Coupler, so that no configuration is needed to activate the protocols.

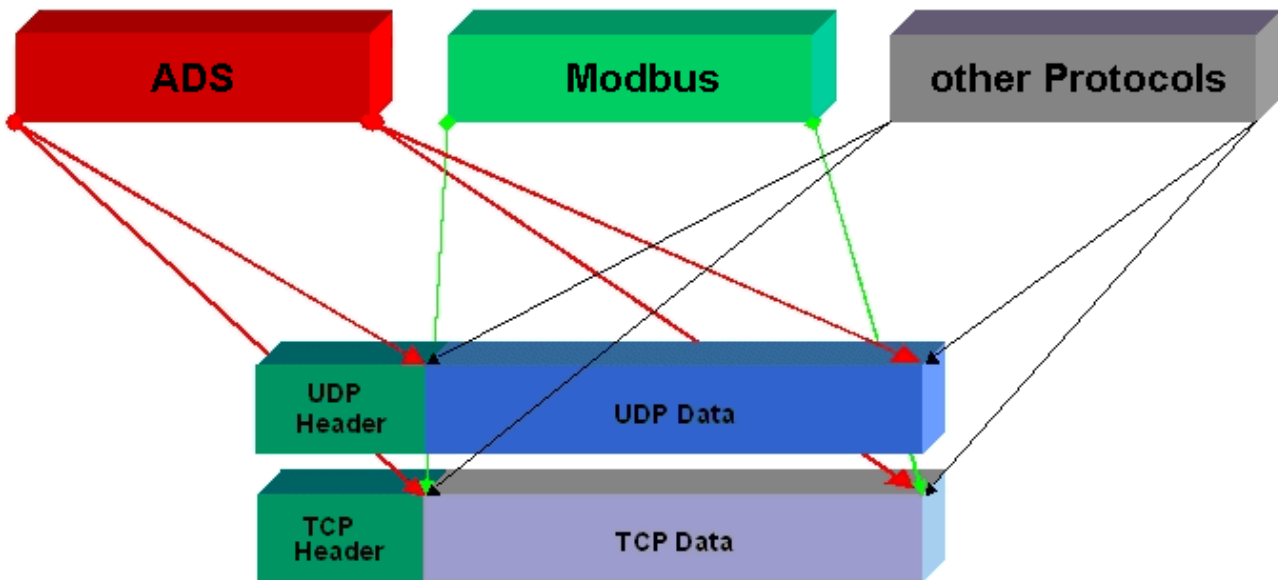

Fig. 23: Protocols running on top of TCP/IP and UDP/IP

ADS can be used on top of either TCP or UDP, but ModbusTCP is always based on TCP/IP.

## 6.2 Topology

In 10BaseT and 100BaseT a number of stations are star connected according to the Ethernet standard.

### Star topology

The simplest form of a star LAN consists of a single point-to-point connection. All messages pass via a central node (the hub or switch), which then passes the information to the desired device according to the destination address.

### Tree topology

A tree topology consists of a number of connected star networks. As soon as the network contains a number of hubs or switches, the topology is classified as a tree. Ideally the connections between the star couplers have a particularly wide bandwidth, since these transport the most traffic. When constructing tree topologies, the repeater rule must be observed. This is also known as the 5-4-3 repeater rule. There must be no more than two pairs of repeaters (or of hubs) in the transmission path between any two stations, unless they are separated by bridges, switches or routers. A transmission path may consist of at most five segments and four repeater sets (two repeater pairs). Up to three of these segments may be coaxial segments to which the stations are connected. The remaining segments must consist of point-to-point connections; these are also known as IRL (inter repeater link) connections.

### Cabling guidelines

*Structured cabling* provides general guidelines for constructing the cabling for a LAN. It specifies maximum permitted cable lengths for the wiring within the grounds, building or floor. Standardized in EN 50173, ISO 11801 and TIA 568-A, *structured cabling* provides the basis for an advanced, application-independent and economical network infrastructure. The wiring standards are applicable to a range defined as having a geographical extent of up to 3 km and an office area of up to one million sq meters, with between 50 and 50,000 end devices. Recommendations for the structure of a cabling system are also given. The figures can vary, depending on the topology selected, the transmission media and coupling modules used under industrial conditions, and on the use of components from various manufacturers in one network. The given figures should therefore only be considered as recommendations.

## 6.3 Reaction times

### BC9000 reaction time

ADS	Time [ms]
TCP	23 to 50 ms + task time on the BC9000 (jitter)
UDP	2 to 3 ms + task time on the BC9000 (jitter)

Modbus	Time [ms]
TCP	12 to 15 ms + task time on the BC9000 (jitter) (default)
Fast TCP*	1 to 3 ms + task time on the BC9000 (jitter)

\* as from firmware B7, Table 100, Register 29 - "1" Fast TCP / "0" TCP ([see Modbus Interface](#)) [[▶ 58](#)]

### BK9000 reaction time

ADS	Time [ms]
TCP	23 to 50 ms
UDP	2 to 3 ms



<b>RT-Ethernet**</b>	<b>Time [ms]</b>
RAW	< 1 ms + K-bus (depending on the K-bus propagation delay)

<b>Modbus</b>	<b>Time [ms]</b>
TCP	12 to 15 ms (default)
Fast TCP*	1 to 3 ms

\* as from firmware B5, Table 100 Register 29 - "1" Fast TCP / "0" TCP (see Modbus interface) [▶ 58]\*\* from firmware B8

## 6.4 Real-time Ethernet

### 6.4.1 Real-time Ethernet with Fast-ADS

The Fast ADS protocol is based on Ethernet. In combination with TwinCAT, this bus system has real-time capability and reaches cycle times of < 1 ms. The real-time Ethernet driver was developed for Windows 2000, Windows XP and Intel Ethernet chips.

Further information can be found at [http://www.pc-control.net/pdf/022002/pcc\\_ethernet\\_d.pdf](http://www.pc-control.net/pdf/022002/pcc_ethernet_d.pdf).

#### BK9000

The Fast-ADS protocol is implemented in addition to the already existing protocols on the BK9000 from firmware version B8. Simultaneous utilization is only possible, if the function ADS was selected in the System Manager (*IP address* tab). If the *NoRealTimeFlag* function is not selected, communication can only take place via Fast-ADS.

With Fast-ADS the watchdog is set to 100 ms. If it is triggered (e.g. when TwinCAT stops), all other Ethernet services are usable again. The K-bus works synchronous with the Fast ADS.

#### B900

RT-Ethernet or Fast-ADS is implemented on all B900 modules. The cycle time of the TwinCAT task must be shorter than 10 ms. Otherwise the process image and thus the outputs of the module and the connected extensions will be reset after 10 ms.

#### Settings in the System Manager

##### BK9000 tab

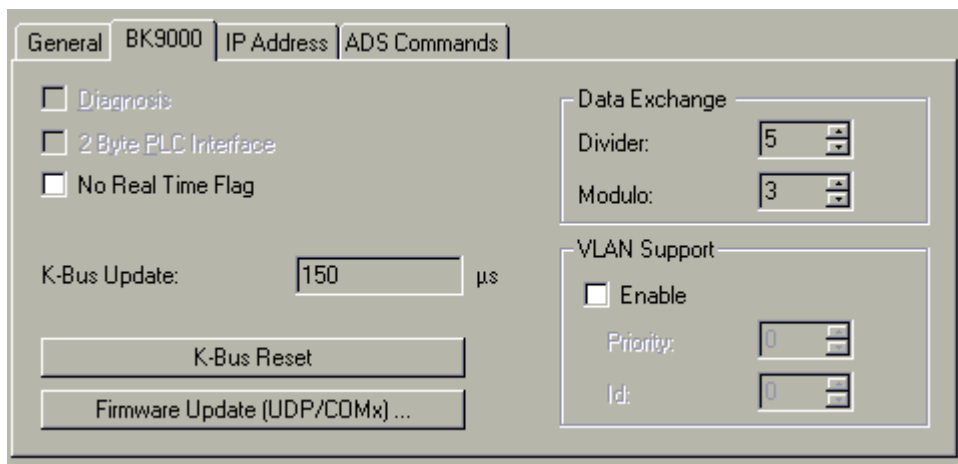

Fig. 24: BK9000 tab

#### No Real Time Flag

TCP/IP or UDP telegrams can also be received if the checkbox is activated. However, the jitter of the real-time telegrams increases!

#### K-bus reset

A reset is triggered on the K-bus.

## Data Exchange

The number of task cycles after which a telegram should be sent to the fieldbus station (Bus Coupler / Fieldbus Box) is determined here.

Modulo specifies the task in which the telegram should be dispatched. This enables the system performance to be optimized.

Sample: Divider 5 and Modulo 3 – a telegram is sent after every 5<sup>th</sup> task (the third to be specific).

## VLAN

Switches that support VLAN (virtual LANs) can prioritize the incoming telegrams with this.

## IP address tab

Fig. 25: IP address tab

### Host Name

The name of the fieldbus station (Bus Coupler / Fieldbus Box) can be edited here.

### IP Address

The IP address of the fieldbus station (Bus Coupler / Fieldbus Box) must be entered here.

### GetHostByName

Using this button an IP address can be obtained from a DHCP server (Dynamic Host Configuration Protocol Server) (BK9000: from firmware version B2).

### Set IP Address

Using this button the IP address is set via ARP.

### AMS address

Specifies the AMS-Net ID of the fieldbus station (Bus Coupler / Fieldbus Box). It is generated automatically by appending two additional byte values (".1.1") to the IP address.

### BootP

This checkbox can be activated if the Beckhoff BootP server has been installed and started (as from TwinCAT Version 2.8).

**New MAC Addresses**

If the Beckhoff BootP server has started, the new MAC addresses (Media Access Controller addresses) can be displayed by pressing this button. The new addresses are displayed in the field under the button.

If only one fieldbus station has been connected, then accordingly only one new MAC address will be displayed.

A desired IP address can then be assigned to this MAC address in the *IP Address* field described above.

If further fieldbus stations are then connected, you can repeat this procedure on the *IP Address* tabs for these stations.

**Communication Settings**

Settings for communication via ADS or RAW.

**6.5 ADS-Communication**

**6.5.1 ADS-Communication**

The ADS protocol (ADS: Automation Device Specification) is a transport layer within the TwinCAT system. It was developed for data exchange between the different software modules, for instance the communication between the NC and the PLC. This protocol enables communication with other tools from any point within the TwinCAT. If communication with other PCs or devices is required, the ADS protocol can use TCP/IP as a basis. Within a networked system it is thus possible to reach all data from any point.

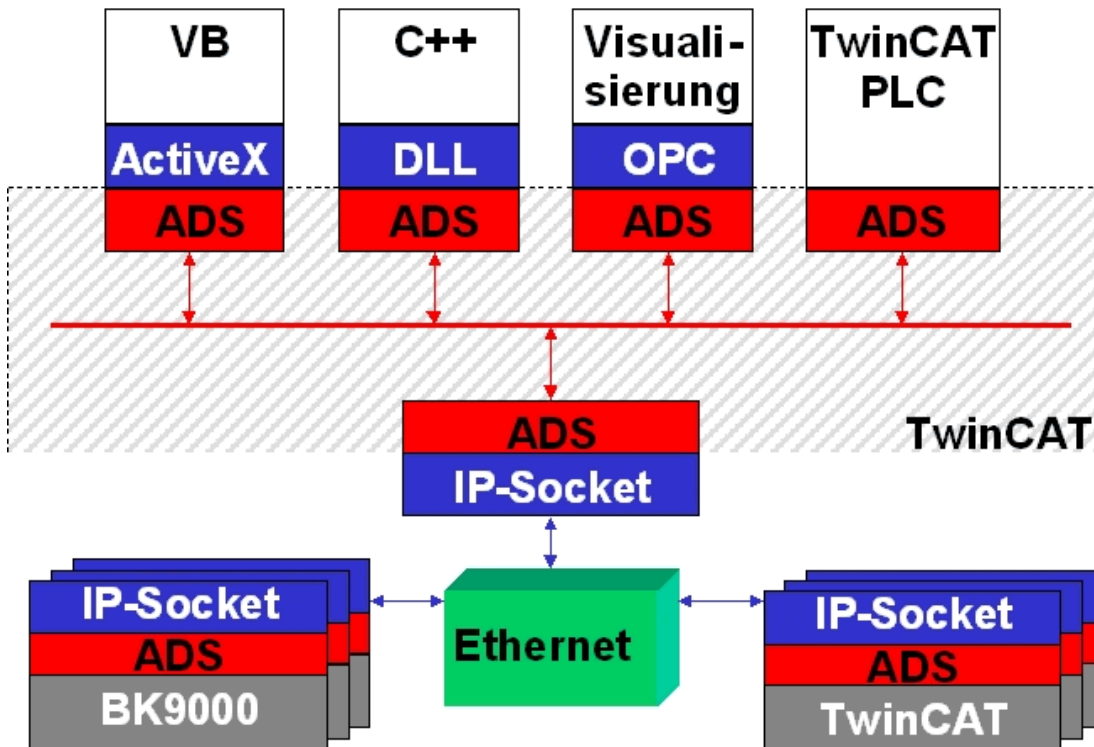

Fig. 26: The ADS protocol as a transport layer within the TwinCAT system

The ADS protocol runs on top of the TCP/IP or UDP/IP protocols. It allows the user within the Beckhoff system to use almost any connecting route to communicate with all the connected devices and to parameterize them. Outside the Beckhoff system a variety of methods are available to exchange data with other software tools.

## Software interfaces

### ADS-OCX

The ADS-OCX is an Active-X component. It offers a standard interface to, for instance, Visual Basic, Delphi, etc.

### ADS-DLL

You can link the ADS-DLL (DLL: Dynamic Link Library) into your C program.

### OPC

The OPC interface is a standardised interface for communication used in automation engineering. Beckhoff offer an OPC server for this purpose.

## 6.5.2 ADS protocol

The ADS functions provide a method for accessing the Bus Coupler information directly from the PC. ADS function blocks can be used in TwinCAT PLC Control for this. The function blocks are contained in the *TcSystem.lib* library. It is also equally possible to call the ADS functions from AdsOCX, ADSDLL or OPC. It is possible to access all the data through ADS port number 300, and to access the registers of the Bus Coupler and Bus Terminals through ADS port number 100.

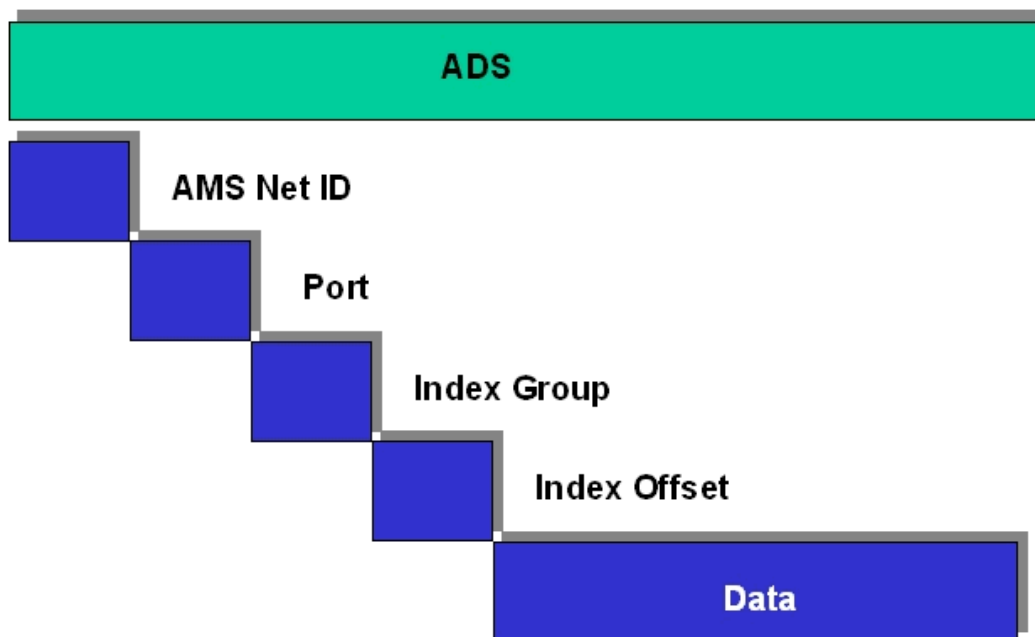

Fig. 27: Structure of the ADS protocol

### AMSNNetID

The AMSNetID provides a reference to the device that is to be addressed. This is created from the set TCP/IP address and an additional 2 bytes. These additional 2 bytes consist of "1.1", and cannot be altered.

Sample:

IP address 172.16.17.128

AMSNNetID 172.16.17.128.1.1

**Port number**

The port number distinguishes sub-elements in the connected device.  
 Port 100: register access  
 Port 300: fieldbus process data  
 Port 800: local process data (BC90x0, C900 only)

**Index group**

The index group distinguishes different data within a port.

**Index offset**

Indicates the offset, from which reading or writing the byte is to start.

**Len**

Gives the length of the data, in bytes, that is to be read or written.

**TCP port number**

The TCP port number for the ADS protocol is 48898 or 0xBF02.

**6.5.3 ADS services**



**User data of an ADS telegram**

The maximum size of the user data in an ADS telegram is 1900 bytes.

**Process data port 300**

The fieldbus data is accessed via ADS port number 300. The data is monitored by a watchdog. If no further telegram arrives within 1000 ms the outputs will be switched to the safe state.

Index group	Meaning	Index offset (value range)
0xF020	Inputs	0...511
0xF030	Outputs	0...511

**Local process image port 800 (BC9000, C900 only)**

Data can be read from and written to the local process image. If it is necessary for outputs to be written, it is important to ensure that they are not used by the local PLC, because the local controller will overwrite these values. The data are not associated with a watchdog, and therefore must not be used for outputs that would have to be switched off in the event of a fault.

Index group	Meaning	Index offset (value range)
0xF020	Inputs	0...511
0xF030	Outputs	0...511
0x4020	Flags (BC 9000, C900 only)	0...4096

**ADS services**

**AdsServerAdsStateB7**

Data type (read only)	Meaning
String	Start - the local PLC is running Start - the local PLC is stopped

**AdsServerDeviceStateB7**

Data type (read only)	Meaning
INT	0 - Start - the local PLC is running 1 - Stop - the local PLC is stopped

**AdsServerTypeB7**

Data type (read only)	Meaning
String	Coupler_PLC

**ADSWriteControlBA**

Data type (write only)	Meaning
NetID	Net ID of the BC9000,C900
Port	800
ADSSTATE	5 - RUN / 6 - STOP
DEVSTATE	0
LEN	0
SRCADDR	0
WRITE	rising edge starts the block
TMOU	example: t#1000 ms

● **Acyclic data communication**

**i** With acyclic data communication it is important to note that about 20 to 30 ms are required in order to establish a TCP/IP connection. Following the successful establishment of a connection the ADS data are sent or read. An ADS read of 1000 bytes takes about 50 ms. If no data are transmitted for 10 seconds, the TCP/IP connection is disconnected from the BC/BK9000, B/C900.

**Register port 100**

The ADS port number in the BK/BC9000, B/C900 for register communication is fixed, being set at 100.

Index group	Index offset (value range)		Meaning
	Hi-Word	Lo-Word	
0	0...127	0...255	Registers in the Bus Coupler Hi-Word, table number of the Bus Coupler Lo-Word, register number of the table
1...64	0...3	1...64	Register of the Bus Terminals Hi-Word, channel number Lo-Word, register number of the Bus Terminal

● **Timeout of the ADS function block**

**i** When reading the register, the time out of the ADS block has to be set to a time longer than 1 second.

● **Setting the password**

**i** When writing to the registers, the password has to be set (see the documentation for the particular Bus Terminal).



**Access control and IP - AMS-Net ID assignment<sup>B6</sup>**

The *AMS Net-Id* table permits access control to the BC 9000, C900 via AMS. As soon as this table has entries, only those AMS devices that have been entered will be able to access the BC 9000. Furthermore, an assignment of the AMS-Net ID to the IP address of the node is explicitly done here. The *AMS Net-Id* table can be filled with ADS write commands: a maximum of 10 entries is possible.

**The structure**

AMS Net ID	Size
AMS Net ID	6 byte
IP address	4 byte
Reserve	2 byte
Reserve	4 byte
Reserve	4 byte

Access takes place via port number: 10,000

Index group: 700

Index Offset (Write)	Comment	Data
0	Add an entry	Data structure, 20 bytes
1	Delete an entry	-
2	Delete all entries	-
10	Save the table in Flash memory	-

Index Offset (Read)	Comment	Data
0	Number of entries	2 byte
1..10	Entry n (1...10)	Data structure, 20 bytes



**First entry**

The first entry must be the device that his writing into the table, because the settings have immediate effect. Make sure that all the settings are correct. The table can also be deleted if the end terminal only is inserted, and the DIP switches 1 to 7 are set to ON.

\* as from firmware B6  
 \*\* as from firmware B7  
 )<sup>2</sup> as from firmware BA

See the [example](#) [▶ 55].

**6.5.4 AMS routing table**

The AMS routing table can be used for two functions:

1. If the AMS Net ID does not match the TCP/IP address, the link between the two non-matching numbers can be entered here.  
 The AMS Net ID matches the TCP/IP address if the first 4 bytes are identical and the AMS Net ID ends with ".1.1".
2. Only AMS Net IDs stored in the table can access the BC9000 via ADS.

Please ensure that all ADS devices with which communication is required are entered in the table. If the table is empty (default), all ADS devices can access the BC9000.

**Processing the AMS routing table using the KS2000 configuration software**

From KS2000 version 4.3.0.39 entries in the AMS routing table can be made via dialog.

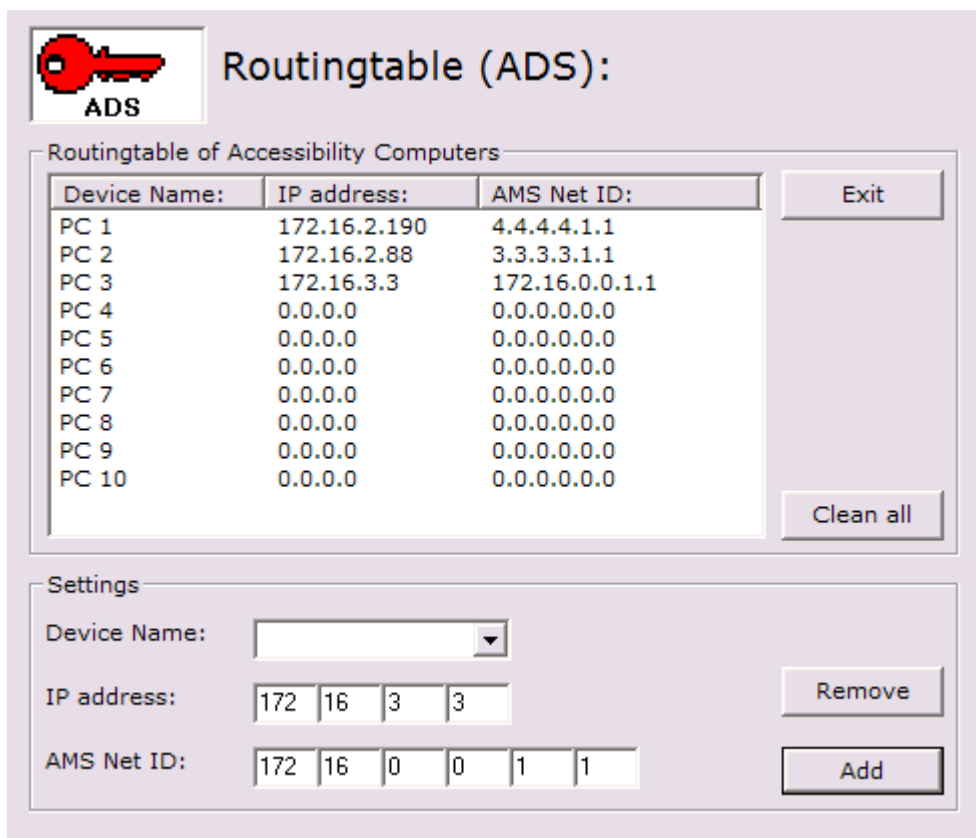

Fig. 28: Displaying the AMS routing table using the KS2000 configuration software

### Entering values in the routing table via ADS

The AMS routing table can be loaded into the BC9000 via ADS. Ensure that the first entry is that of the sender, since this setting becomes effective immediately and may otherwise prevent further entries in the AMS routing table.

 Download

([https://infosys.beckhoff.com/content/1033/BK9x00\\_BK9050/Resources/6744240267/.zip](https://infosys.beckhoff.com/content/1033/BK9x00_BK9050/Resources/6744240267/.zip))

## 6.6 ModbusTCP

### 6.6.1 Examples for ModbusTCP

Examples for Modbus TCP are contained in this help text.

Simple example: Modbus TCP via VB6.0

 Download [https://infosys.beckhoff.com/content/1033/BK9x00\\_BK9050/Resources/2802254731/.zip](https://infosys.beckhoff.com/content/1033/BK9x00_BK9050/Resources/2802254731/.zip)

Sample: ModbusTCP via VB6.0, set and reset of the watchdog:

 Download [https://infosys.beckhoff.com/content/1033/BK9x00\\_BK9050/Resources/2802256907/.zip](https://infosys.beckhoff.com/content/1033/BK9x00_BK9050/Resources/2802256907/.zip)

### 6.6.2 ModbusTCP Protocol

The Ethernet protocol is addressed by means of the MAC-ID. The user does not normally need to be concerned about this address. The IP number has a length of 4 bytes, and must be parameterized by the user on the Bus Coupler and in the application. In ModbusTCP, the TCP port is set to 502. The UNIT can be freely selected under ModbusTCP, and does not have to be configured by the user.

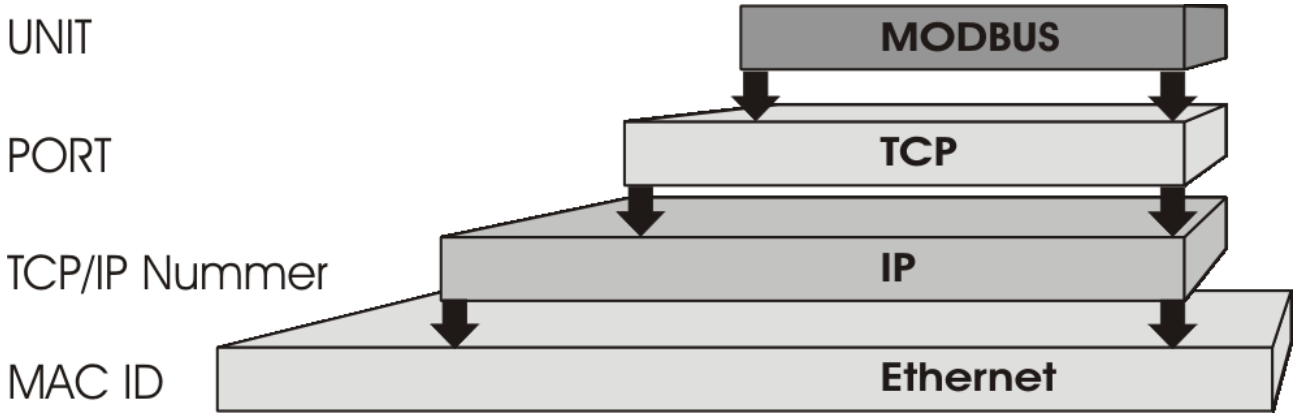

Fig. 29: ModbusTCP Protocol

#### TCP port number

The TCP port number for ModbusTCP has been standardised to 502.

#### Modbus-Unit

The unit is returned by the slave.

#### ModbusTCP Protocol

Byte	Name	Description
0	Transaction identifier	is returned by the slave
1	Transaction identifier	is returned by the slave
2	Protocol identifier	always 0
3	Protocol identifier	always 0
4	Length field	0 (if the message is less than 256 bytes in length)
5	Length field	Number of following bytes
6	UNIT identifier	returned by the slave
7	Modbus	Modbus protocol beginning with the function follows

### 6.6.3 Modbus TCP interface

Address		Description		
0x0000 0x00FF		Process data interface Inputs		
0x0800 0x08FF		Process data interface Outputs		
0x1000 0x1006	Read only	Bus Coupler identification		
0x100A		2 byte PLC interface		
0x100B		Bus terminal diagnosis		
0x100C		Bus Coupler status		
0x1010		Process image length in bits, analog outputs (without PLC variables)		
0x1011		Process image length in bits, analog inputs (without PLC variables)		
0x1012		Process image length in bits, digital outputs		
0x1013		Process image length in bits, digital inputs		
0x1020		Watchdog, current time in [ms]		
0x110A		Read / Write	2 byte PLC interface	
0x110B			Bus terminal diagnosis	
0x1120			Watchdog, pre-defined time in [ms] (Default value: 1000)	
0x1121	Watchdog reset register			
0x1122	Type of watchdog		1	Telegram watchdog (default)
			0	Write telegram watchdog
0x1123**	ModbusTCP mode**		1	Fast Modbus
			0	Normal Modbus (default)
0x4000* 0x47FF		Flags area (%MB..)*		

\* all Bus Terminal controllers BC9xx0 and BX9000

\*\* for BC9x00 from firmware B7 and BK9000 from firmware B5 and all unlisted BK9xxx and BC/BX9xxx

#### Watchdog

The watchdog is active under the factory settings. After the first write telegram the watchdog timer is initiated, and is triggered each time a telegram is received from this device. Other devices have no effect on the watchdog. A second approach, which represents a more sensitive condition for the watchdog, is for the watchdog only to be re-triggered after each write telegram. To do this, write a zero into register 0x1122 (default value "1").

The watchdog can be deactivated by writing a zero to offset 0x1120. The watchdog register can only be written if the watchdog is not active. The data in this register is retained.

#### Watchdog register

If the watchdog timer on your slave has elapsed it can be reset by writing twice to register 0x1121. The following must be written to the register: 0xBECF 0xAFFE. This can be done either with function 6 or with function 16.

#### The Bus Coupler's status register

Bit	15	14	13	12	11	10	9	8	7	6	5	4	3	2	1	0
Name	FB	-	-	-	-	-	-	-	-	-	-	-	-	-	CNF	KB

**Legend**

Bit	Name	Value	Description
15	FB	1 <sub>bin</sub>	Fieldbus error, watchdog time elapsed
14...2	-	-	reserved
1	CNF	1 <sub>bin</sub>	Bus Coupler configuration error
0	KB	1 <sub>bin</sub>	Bus Terminal error

**ModbusTCP mode**

The fast Modbus mode should only be used in small local networks. The fast ModbusTCP is not active under the default settings. If problems are found to occur with this type of communication, the Bus Coupler should be switched to "normal" ModbusTCP communication. The mode is set in the Modbus interface, offset 0x1123. It is necessary to reset the coupler (e.g. using ModbusTCP function 8) after the change. It is not permitted to send more than one Modbus service within one Ethernet frame in fast Modbus mode.

**2 byte PLC interface**

Registers in the complex terminals and Bus Terminal Controller registers can be both read and written using the 2 byte PLC interface. The complex terminal registers are described in the associated terminal documentation. The Bus Coupler registers can be used, for example, to read terminal bus diagnostics data, the terminal composition or the cycle times, and the programmed configuration can be written. It is also possible for a manual K-bus reset to be carried out. The 2-byte PLC interface requires two bytes each of input and output data. They are handled using a special protocol. A description of the 2 byte PLC interface, the registers available in the Bus Couplers and of function blocks for various PLC systems that support the 2 byte PLC interface can be supplied on request.

**2 byte diagnostic interface**

The terminals' error messages can be sent over the 2-byte diagnostic interface. K-bus diagnostics must however be activated for this purpose. The 2-byte diagnostic interface occupies two bytes each of input and output data. A special protocol is processed via these two bytes. A description of the 2 byte-diagnostic interface can be supplied on request.

**6.6.4 ModbusTCP slave error answer (BK9000, BX/BC9xx0, BC9191, IP/ILxxxx-B/C900, EK9000)**

When the user sends the slave either a request or information that the coupler does not understand, the slave responds with an error report. This response contains the function and the error code. 0x80 is added to the value returned by the function.

Code	Name	Meaning
1	ILLEGAL FUNCTION	Modbus function not implemented
2	ILLEGAL DATA ADDRESS	Invalid address or length
3	ILLEGAL DATA VALUE	Invalid parameters - Diagnostic functions - Wrong register
4	SLAVE DEVICE ERROR	Watchdog or K-bus error EK9000: E-bus error
6	SLAVE DEVICE BUSY	Output data is already been received from another IP device

## 6.6.5 ModbusTCP functions

### 6.6.5.1 ModbusTCP functions

In the Modbus protocol, the functions determine whether data is to be read or written, and what kind of data is involved.

Function	Code	Description
<a href="#">Read coil status [► 60]</a>	1	Read digital outputs
<a href="#">Read input status [► 61]</a>	2	Read digital inputs
<a href="#">Read holding register [► 61]</a>	3	Read analog outputs and inputs / GPR
<a href="#">Read input register [► 62]</a>	4	Reading the inputs / GPR
<a href="#">Force single coil [► 62]</a>	5	Writing a digital output
<a href="#">Preset single register [► 63]</a>	6	Writing an output / GPR
<a href="#">Diagnostics [► 63]</a>	8	Diagnostics
<a href="#">Force multiple coils [► 65]</a>	15	Write a number of digital outputs
<a href="#">Preset multiple register [► 66]</a>	16	Writing several outputs / GPRs
<a href="#">Read / write registers [► 66]</a>	23	Write and read a number of process data outputs / GPRs

GPR (General Preset Register) - register structure of the Modbus interface (see appendix)

### 6.6.5.2 Read coil status (Function 1)

The *Read coil status* function can be used to read the digital outputs that have been set.

The first 10 digital outputs are read in this example. The start address is zero. An offset can be entered in the *Start address* field

#### Query

Byte name	Sample
Function code	1
Start address high	0
Start address low	0
Count high	0
Count low	10

The fieldbus coupler answers with *byte count 2*, i.e. 2 bytes of data are returned. The query was for 10 bits, and these are now distributed over 2 bytes. The third bit is set in the output process image, and the fieldbus coupler shows the value 4 in the first data byte.

#### Response

Byte name	Sample
Function code	1
Byte count	2
Data bits 0...7	4
Data bits 8...18	0

### 6.6.5.3 Read input status (Function 2)

The *Read input status* function can be used to read the digital input data. The first 10 digital inputs are read in this example. The start address is zero. An offset can be entered in the *Start address* field

#### Query

Byte name	Sample
Function code	2
Start address high	0
Start address low	0
Count high	0
Count low	10

The fieldbus coupler answers with *byte count 2*, i.e. two bytes of data are returned. The query was for 10 bits, and these are now distributed over 2 bytes. The third bit is set in the output process image, and the fieldbus coupler shows the value 4 in the first data byte.

#### Response

Byte name	Sample
Function code	2
Byte count	2
Data bits 0..7	1
Data bits 8..18	0

### 6.6.5.4 Read holding register (Function 3)

The *Read holding register* function can be used to read the input and output words and the registers. Inputs from offset 0 - 0xFF and outputs from offset 0x800 - 0x8FF, and for controllers (BC, BX) the flag area from offset 0x4000.

In this example the first two analog outputs (or two output words) are read. The analog outputs (or output words) start at offset 0x800. The length indicates the number of channels (or words) to be read.

#### Query

Byte name	Sample
Function code	3
Start address high	8
Start address low	0
Count high	0
Count low	2

The fieldbus coupler answers with *byte count 4*, i.e. 4 bytes of data are returned. The query was for two analog channels, and these are distributed over two words. In the analog output process image, the first channel has the value 0x3FFF, while the second channel has the value 0x0.

**Response**

Byte name	Sample
Function code	3
Byte count	4
Data 1 high byte	63
Data 1 low byte	255
Data 2 high byte	0
Data 2 low byte	0

**6.6.5.5 Read input register (Function 4)**

The function *Read input register* reads the inputs on a word basis.

In this example the first two analog inputs (or the first two input words) are read. The analog inputs (or input words) start at an offset of 0x0000. The length indicates the number of words to be read. A KL3002, for example, has two words of input data. Therefore, the length to be entered at *Number low* is two.

**Query**

Byte name	Sample
Function code	4
Start address high	0
Start address low	0
Count high	0
Count low	2

The fieldbus coupler answers with byte count 4, i.e. four bytes of data are returned. The query was for two analog channels, and these are now distributed over 2 words. In the analog input process image, the first channel has the value 0x0038, while the second channel has the value 0x3F1B.

**Response**

Byte name	Sample
Function code	4
Byte count	4
Data 1 high byte	0
Data 1 low byte	56
Data 2 high byte	63
Data 2 low byte	11

**6.6.5.6 Force single coil (Function 5)**

The *Force single coil* function can be used to write a digital output. The third digital output is written in this example. The digital outputs start at address 0x0000. The digital value is located in *Data high*. To switch the output on, *Data high* must contain the value 0xFF, while 0x00 is used to switch the output off again. *Data low* must contain the value 0x00.



**Query**

Byte name	Sample
Function code	5
Start address high	0
Start address low	2
Data high	255
Data low	0

The coupler answers with the same telegram.

**Response**

Byte name	Sample
Function code	5
Start address high	0
Start address low	2
Data high	255
Data low	0

**6.6.5.7 Preset single register (Function 6)**

The function *Preset singles register* can be used to access the output or flag process image (only for controllers) and the [Modbus TCP interface \[► 58\]](#).

Function 6 writes the first output word. The outputs start at an offset of 0x0800. Here again the offset always describes a word. This means offset 0x0803 refers to the fourth word in the output process image.

**Query**

Byte name	Sample
Function code	6
Start address high	8
Start address low	0
Data high	63
Data low	255

The Fieldbus Coupler replies with the same telegram and confirmation of the received value.

**Response**

Byte name	Sample
Function code	6
Start address high	8
Start address low	0
Data high	63
Data low	255

**6.6.5.8 Diagnosis (Function 8)**

The diagnosis function provides a series of tests for checking the communication system between the master and the slave and for examining a variety of internal error states within the slave. A broadcast telegram is not supported.

The function uses two bytes in the query to specify a sub-function code defining the test that is to be carried out. The slave returns the function code and the sub-function code in the response.

The diagnostic queries use a two-byte data field to send diagnostics data or control information to the slave.

**Query**

Byte name	Sample
Function code	8
Sub-function high	0
Sub-function low	0
Data high	2
Data low	3

**Response**

Byte name	Sample
Function code	8
Sub-function high	0
Sub-function low	0
Data high	2
Data low	3

**Echo a request (Subfunction 0)**

Subfunction 0 causes the data that is sent to the slave by the master to be returned.

**Coupler reset (Subfunction 1)**

The coupler is reset with sub-function 1, error counters are reset and the controller performs a self-test. No telegrams are either received or sent while the controller is being reset. The IP socket is closed.

**● Last reply with the sub-function 1**

**i** Before the Controller restarts it sends a reply with sub-function 1, after which the IP socket is closed.

Sub-function	Data field (query)	Data field (response)
0x0001	0x0000	0x0000

**Delete all counter contents (sub-function 10)**

When this sub-function is called the controller clears all error counters.

Sub-function	Data field (query)	Data field (response)
0x000A	0x0000	Echo query data

**Bus Communication Answer Counter (Subfunction 11)**

Returns the number of communication answers.

Sub-function	Data field (query)	Data field (response)
0x000B	0x0000	Counter value

**Error Answer Counter (Subfunction 13)**

This counter contains the number of error answer telegrams that the coupler has sent.

Sub-function	Data field (query)	Data field (response)
0x000D	0x0000	Counter value

The following functions contain the counter states for various units. This means that the Modbus telegrams can be distinguished through their units, if, for example, a coupler is accessed by different masters.

**Slave Answers (Subfunction 14)**

Contains the number of answers that the slave has sent.

Sub-function	Data field (query)	Data field (response)
0x000E	0x0000	Counter value

**Number of unanswered telegrams (Subfunction 15)**

Contains the number of answers that the slave has not sent.

Sub-function	Data field (query)	Data field (response)
0x000F	0x0000	Counter value

**Number of Error Answers (Subfunction 16)**

Contains the number of error answers that the slave has sent.

Sub-function	Data field (query)	Data field (response)
0x0010	0x0000	Counter value

**6.6.5.9 Force multiple coils (Function 15)**

The *Force multiple coils* function can be used to set or reset a number of digital outputs at the same time.

The first 20 digital outputs are written in this example. The digital outputs start at an offset of 0x0000. Here the offset always describes a bit. Offset 0x0003 writes to the fourth bit in the output process image. The length indicates the number of bits, and the *Byte count* is composed from the combination all the bytes that are to be written.

Sample: 20 bits count is 3 bytes (round up to the nearest byte)

The data bytes contain the values for the individual bits. In this example, the bits 0 to 15 are set to TRUE, while bits 17 to 20 are set to FALSE.

**Query**

Byte name	Sample
Function code	15
Start address high	0
Start address low	0
Length high	0
Length low	20
Byte count	3
Data 1 bit 0..7	255
Data 2 bit 8..15	255
Data 3 bit 16..23	0

**Response**

The Bus Coupler answers with the same telegram.

Byte name	Sample
Function code	15
Start address high	0
Start address low	0
Length high	0
Length low	20

### 6.6.5.10 Preset multiple register (Function 16)

The *Preset multiple register* function can be used to write a number of outputs. The first two analog output words are written in this example. The outputs start at an offset of 0x0800. Here the offset always describes a word. Offset 0x0003 writes to the fourth word in the output process image. The length indicates the number of words, and the *Byte count* is formed from the combination of all the bytes that are to be written.

Sample: 4 words - correspond to a byte count of 8

The data bytes contain the values for the analog outputs. In this example, two words are to be written. The first word is to receive the value 0x7FFF, and the second word is to receive the value 0x3FFF.

#### Query

Byte name	Sample
Function code	16
Start address high	8
Start address low	0
Length high	0
Length low	2
Byte count	4
Data 1 byte 1	127
Data 1 byte 2	255
Data 2 byte 1	63
Data 2 byte 2	255

#### Response

The coupler replies with the start address and the length of the transmitted words.

Byte name	Sample
Function code	16
Start address high	8
Start address low	0
Length high	0
Length low	2

### 6.6.5.11 Read / write registers (Function 23)

A number of analog outputs can be written and a number of analog inputs read with one telegram using the *Read / write registers* function. In this example the first two analog output words are written, and the first two analog inputs are read. The analog outputs start at offset 0x0800, while the inputs start at offset 0x0000. Here the offset always describes a word. Offset 0x0003 writes to the fourth word in the output process image. The length indicates the number of words, and the *Byte count* is formed from the combination of all the bytes that are to be written. Sample: 4 words - correspond to a byte count of 8

The data bytes contain the values for the analog outputs. In this example, two words are to be written. The first word is to receive the value 0x3FFF, and the second word is to receive the value 0x7FFF.

**Query**

Byte name	Sample
Function code	23
Read start address high	0
Read start address low	0
Read length high	0
Read length low	2
Write start address high	8
Write start address low	0
Write length high	0
Write length low	2
Byte count	4
Data 1 high	63
Data 1 low	255
Data 2 high	127
Data 2 low	255

**Response**

The coupler replies with the start address and the length of the bytes to be transferred in *Byte count*. The data information follows. In this example the first word contains 0x0038 while the second word contains 0x3F0B.

Byte name	Sample
Function code	23
Byte count	4
Data 1 high	0
Data 1 low	56
Data 2 high	63
Data 2 low	11

## 6.7 Description of parameters

### 6.7.1 Register settings, Table 100

The registers can be set through a dialog using the KS2000 configuration software, or it is possible to write into the registers directly.

Register	Description	Default	Bus Terminal Controller
0...1	IP address	0xAC, 0x10, 0x11, 0x00	BC9000, BC9100, BK9000, BK9050, BK9100
2...3	IP mask	0xFF, 0xFF, 0x00, 0x00	BC9000, BC9100, BK9000, BK9050, BK9100
4...13	Device Name	BC9000	BC9000, BC9100, BK9000, BK9050, BK9100
14	Watchdog AMS/ADS	1000 ms	BC9000, BC9100, BK9000, BK9050, BK9100
15.0	0 <sub>bin</sub> enable ModbusTCP	0 <sub>bin</sub>	BC9000, BC9100, BK9000, BK9050, BK9100
	1 <sub>bin</sub> disable ModbusTCP		
15.1	0 <sub>bin</sub> enable AMS/ADS	0 <sub>bin</sub>	BC9000, BC9100, BK9000, BK9050, BK9100
	1 <sub>bin</sub> disable AMS/ADS		
16.8	0 <sub>bin</sub> Ethernet mode half duplex	1 <sub>bin</sub>	BC9000, BC9100, BK9000, BK9050, BK9100
	1 <sub>bin</sub> Ethernet mode full duplex		
16.12	0 <sub>bin</sub> Autobaud off	1 <sub>bin</sub>	BC9000, BC9100, BK9000, BK9050, BK9100
	1 <sub>bin</sub> Autobaud on		
16.13	0 <sub>bin</sub> 10 Mbaud	1 <sub>bin</sub>	BC9000, BC9100, BK9000, BK9050, BK9100
	1 <sub>bin</sub> 100 Mbaud		
17...18	Default Gateway	0x00, 0x00, 0x00, 0x00	BC9000, BC9100, BK9000, BK9050, BK9100
24	Watchdog ModbusTCP	1000 ms	BC9000, BC9100, BK9000, BK9050, BK9100
25.0	Entry of a fieldbus error (connection to switch interrupted) in the flags area diagnosis		BC9000, BC9100
	0 <sub>bin</sub>	Error was not entered	
	1 <sub>bin</sub>	Error was entered	
26	ModbusTCP port no.	502	BC9000, BC9100, BK9000, BK9050, BK9100
27	ADS connection service life	10 s	BC9000, BC9100, BK9000, BK9050, BK9100
28	Modbus connection service life	10 s	BC9000, BC9100, BK9000, BK9050, BK9100
29.0	ModbusTCP mode		BC9000, BC9100, BK9000, BK9050, BK9100
	1 <sub>bin</sub>	Fast ModbusTCP	

#### ● **ModbusTCP Connections**

**i** A maximum of three ModbusTCP connections are permitted! Only the first connection gets the read/write access, further connections get only read access. The Modbus client should only send a further request to the bus coupler after the bus coupler has responded to the last request or after a timeout period (> 1 s) has elapsed (recommended 5 seconds). It is also recommended that a certain idle time (> 100 ms) be observed between request and response.

#### ● **Increased network load**

**i** Increased network load due to e.g. incorrectly configured networks may cause the bus coupler to stop responding. Once the network load problem has been eliminated, it may be necessary to reboot the Bus Coupler.

# 7 Error handling and diagnosis

## 7.1 Diagnostic LEDs

### BK9000, BK9100, BC9000, BC9100

After switching on, the Bus Coupler immediately checks the connected configuration. Error-free start-up is indicated when the red *I/O ERR* LED goes out. If the *I/O ERR* LED blinks, an error in the area of the terminals is indicated. The error code can be determined from the frequency and number of blinks. This permits rapid rectification of the error.

The Bus Coupler has two groups of LEDs for the display of status. The upper group with four LEDs indicates the status of the respective fieldbus. The significance of the fieldbus status LEDs is explained in the appropriate sections of this manual. It corresponds to the usual fieldbus display.

On the upper right hand side of the Bus Couplers are two more green LEDs that indicate the supply voltage. The left hand LED indicates the presence of the 24 V supply for the Bus Coupler. The right hand LED indicates the presence of the supply to the power contacts.

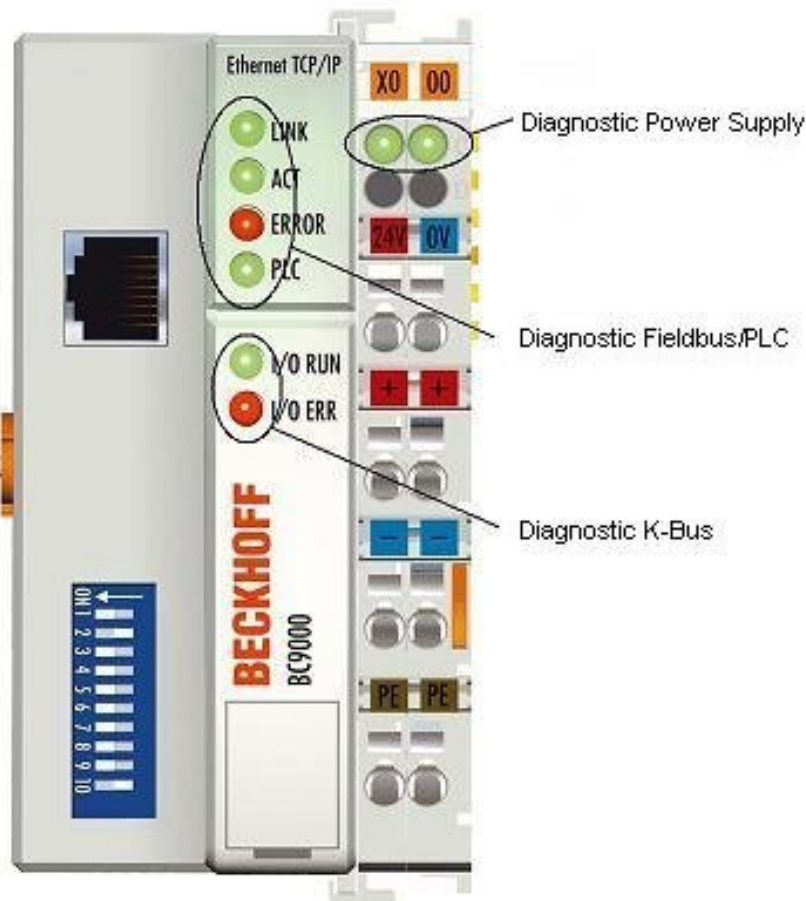

Fig. 30: BC9000 LEDs

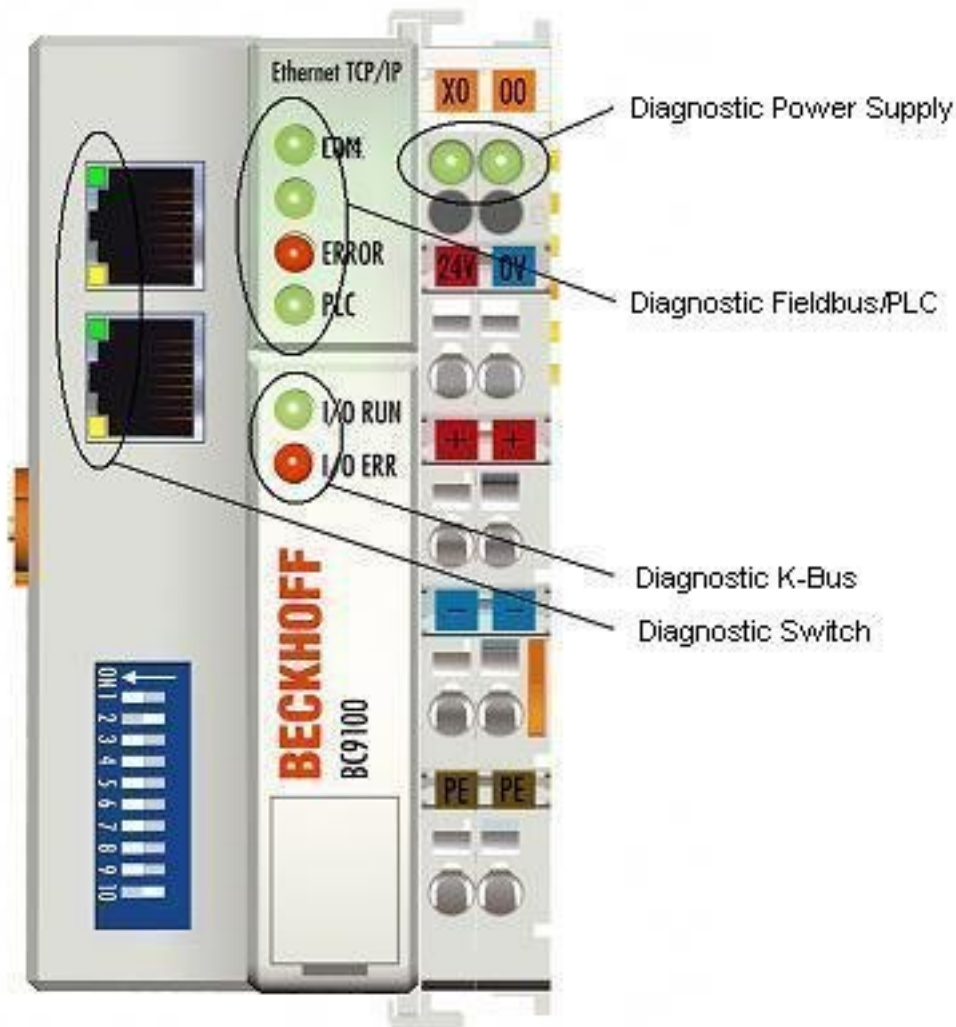

Fig. 31: BC9100 LEDs

**LEDs for power supply diagnostics**

LED	Meaning
Left LED off	Bus Coupler has no power
Right LED off	No 24 V <sub>DC</sub> power supply connected to the power contacts

**LEDs for fieldbus diagnostics**

LED	On	Off
LINK (BK9000/BC9000 only)	Physical connection present	No physical connection present
ACT (BK9000/BC9000 only)	Flashing: Bus traffic present	No bus traffic (bus idle)
COM (BK9100/BC9100 only)	Flashing: data received at the controller	no data are received
ERROR	The LED flashes slowly if DHCP or BootP is active but the Bus Coupler has not yet received an IP address The LED flashes rapidly (5 times, only when switching on); the Bus Coupler is addressed with ARP. The settings on the DIP SWITCH are not valid. LED permanently on (in RT-Ethernet mode only) Note: task time set too fast	No error
PLC (BC9000/BC9100 only)	PLC program is in RUN mode The LED flashes while the boot project is being saved.	PLC program is in stop mode
WDG (BK9000 only)	Watchdog is triggered <ul style="list-style-type: none"> <li>No error</li> </ul>	Watchdog expired or not triggered <ul style="list-style-type: none"> <li>Start communication</li> <li>Reset watchdog error</li> </ul>



**LEDs for K-bus diagnostics**

Error code	Error argument	Description	Remedy
Persistent, continuous flashing		EMC problems	<ul style="list-style-type: none"> <li>Check power supply for undervoltage or overvoltage peaks</li> <li>Implement EMC measures</li> <li>If a K-bus error is present, it can be localized by a restart of the coupler (by switching it off and then on again)</li> </ul>
1 pulse	0	EEPROM checksum error	Set manufacturer's setting with the KS2000 configuration software
	1	Code buffer overflow	Insert fewer Bus Terminals. Too many entries in the table for the programmed configuration
	2	Unknown data type	Software update required for the Bus Coupler
	3	Process data too big	Reduce number of K-bus terminals
2 pulses	0	Programmed configuration has an incorrect table entry	Check programmed configuration for correctness
	n (n > 0)	Table comparison (Bus Terminal n)	Incorrect table entry
3 pulses	0	K-bus command error	<ul style="list-style-type: none"> <li>No Bus Terminal inserted</li> <li>One of the Bus Terminals is defective; halve the number of Bus Terminals attached and check whether the error is still present with the remaining Bus Terminals. Repeat until the defective Bus Terminal is located.</li> </ul>
	n	Break behind Bus Terminal n	Check whether the bus end terminal 9010 is connected.
4 pulses	0	K-bus data error, break behind the Bus Coupler	Check whether the n+1 Bus Terminal is correctly connected; replace if necessary.
	n	Break behind Bus Terminal n	Check whether the bus end terminal 9010 is connected.
5 pulses	n	K-bus error in register communication with Bus Terminal n	Exchange the n <sup>th</sup> bus terminal
6 pulses	0	Error at initialization	Exchange Bus Coupler
	1	Internal data error	Perform a hardware reset on the Bus Coupler (switch off and on again)
	2	DIP switch changed after a software reset from firmware BC9000 BB and BC9100 B0: from firmware BK9000 BA and BK9100 B0:	Perform a hardware reset on the Bus Coupler (switch off and on again)
		IP address already exists in the network	Assign a different IP address
	4	DIP switch incorrect for BootP	Set 1-8 to <i>on</i> or <i>off</i> , see BootP
	8	Internal data error	Perform a hardware reset on the Bus Coupler (switch off and on again)
16	Error in IP socket	Perform a hardware reset on the Bus Coupler (switch off and on again)	
7 pulses (BC9000/BC9100 only)	0	Note: cycle time was exceeded (see Table 1, Register 17)	Warning: the set cycle time was exceeded. This note (flashing of the LED) can only be reset by rebooting the BC. Remedy: increase the cycle time
9 pulses (BC9000/BC9100 only)	0	Checksum error in Flash program	Transmit program to the BC again
	1	Incorrect or faulty library implemented	Remove the faulty library
10 pulses (BC9000/BC9100 only)	n	Bus Terminal n is not consistent with the configuration that existed when the boot project was created	Check the n <sup>th</sup> Bus Terminal. The boot project must be deleted if the insertion of an n <sup>th</sup> Bus Terminal is intentional
14 pulses	n	n <sup>th</sup> Bus Terminal has the wrong format	Start the Bus Coupler again, and if the error occurs again then exchange the Bus Terminal
15 pulses	n	Number of Bus Terminals is no longer correct	Start the Bus Coupler again. If the error occurs again, restore the manufacturer's setting using the KS2000 configuration software
16 pulses	n	Length of the K-bus data is no longer correct	Start the Bus Coupler again. If the error occurs again, restore the manufacturer's setting using the KS2000 configuration software

**LEDs for switch diagnosis (BK9100/BC9100 only)**

LED	On	Flashes	Off
LINK/ACT	Physical connection present	Communication available	No physical connection present
10/100 Mbaud	100 Mbaud	-	10 Mbaud

## 7.2 Diagnostic LEDs

### BK9050

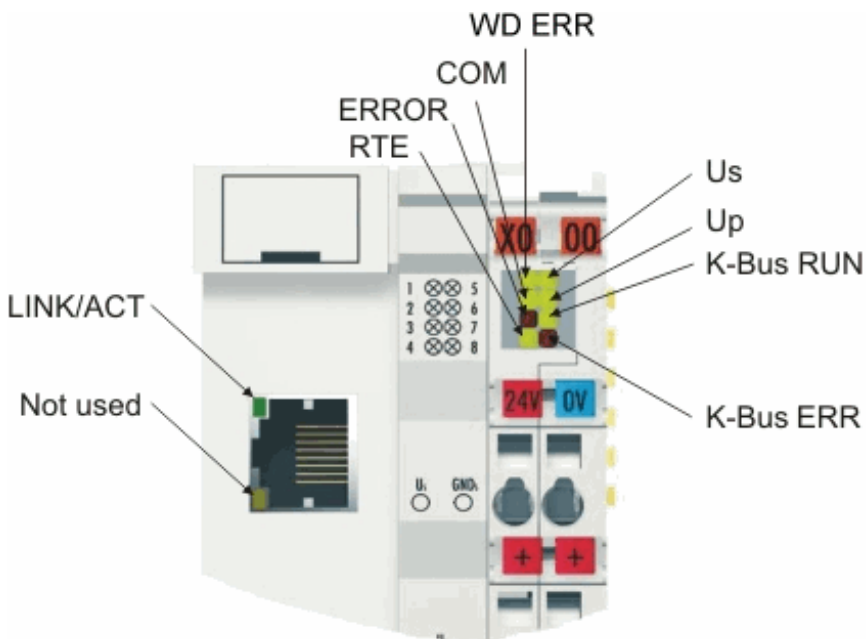

Fig. 32: BK9050 LEDs

#### LEDs for power supply diagnostics

LED (Power LEDs)	Meaning
Us	off: Bus Coupler has no voltage 24 V <sub>DC</sub>
Up	off: No 24 V <sub>DC</sub> power supply connected to the power contacts

#### LEDs for K-bus diagnostics

LED (K-bus)	Meaning
K-bus RUN	on or flashing: K-bus running
K-bus ERR	flashing: (see error code) [▶ 73]

#### LEDs for Ethernet diagnosis

LED (Ethernet)	Meaning
WD ERR	on: Watchdog error
COM	on or flashing: communication with controller
ERROR	flashing: DHCP or BootP active. Waiting for an IP address
RTE	on: hard real-time with TC is switched on. No ADS communication is possible at the same time. All TCP, UPD and ICMP telegrams (e.g. ping) remain unanswered.
LINK/ACT	on: LINK present flashing: LINK present and communication active

**Error code for K-bus diagnosis**

Error code	Error argument	Description	Remedy
-	flashing continuously	EMC problems	<ul style="list-style-type: none"> <li>• Check power supply for undervoltage or overvoltage peaks</li> <li>• Implement EMC measures</li> <li>• If a K-bus error is present, it can be localized by a restart of the coupler (by switching it off and then on again)</li> </ul>
1	0	EEPROM checksum error	Enter factory settings with the KS2000 configuration software
	1	Code buffer overflow	Insert fewer Bus Terminals. Too many entries in the table for the programmed configuration
	2	Unknown data type	Software update required for the Bus Coupler
2	-	Reserve	-
3	0	K-bus command error	<ul style="list-style-type: none"> <li>• No Bus Terminal inserted</li> <li>• One of the Bus Terminals is defective; halve the number of Bus Terminals attached and check whether the error is still present with the remaining Bus Terminals. Repeat until the defective Bus Terminal is located.</li> </ul>
	n	K-bus data error, break behind the Bus Coupler	Check whether the n+1 Bus Terminal is correctly connected; replace if necessary.
4	0	Break behind Bus Terminal n	Check whether the Bus End Terminal KL9010 is connected.
	n	K-bus error in register communication with Bus Terminal n	Exchange the n <sup>th</sup> bus terminal
6	0	Error at initialization	Exchange Bus Coupler
	1	Internal data error	Perform a hardware reset on the Bus Coupler (switch off and on again)
	2	IP address already exists	Check the IP address; the coupler has already found its set IP address in the network
	4	BootP invalid DIP switch setting	With BootP the DIP switches 1-8 must be all On or all Off
7	0	Note: cycle time was exceeded	Warning: the set cycle time was exceeded. This indication (flashing LEDs) can only be cleared by booting the Bus Coupler again. Remedy: increase the cycle time
9	0	Checksum error in Flash program	Transmit program to the BC again
	1	Incorrect or faulty library implemented	Remove the faulty library
10	n	Bus Terminal n is not consistent with the configuration that existed when the boot project was created	Check the n <sup>th</sup> Bus Terminal. The boot project must be deleted if the insertion of an n <sup>th</sup> Bus Terminal is intentional
14	n	n <sup>th</sup> Bus Terminal has the wrong format	Start the Bus Coupler again, and if the error occurs again then exchange the Bus Terminal
15	n	Number of Bus Terminals is no longer correct	Start the Bus Coupler again. If the error occurs again, restore the manufacturers setting using the KS2000 configuration software
16	n	Length of the K-bus data is no longer correct	Start the Bus Coupler again. If the error occurs again, restore the manufacturers setting using the KS2000 configuration software

## 7.3 General errors

### No data exchange after replacing a bus coupler

You have exchanged the Ethernet Bus Coupler and set the same TCP/IP number, but data is not exchanged.

Every Ethernet device has its own, unique MAC-ID. This number is saved when connecting to an Ethernet node, and stored in a table. This table contains the correspondences between the MAC-ID and the TCP/IP number. You must delete this table. Do this in a DOS window, by entering the command "arp -d" and the TCP/IP number of the Bus Coupler.

Sample: >arp -d 172.16.17.203<

If the DHCP protocol or the BootP protocol is active it is necessary to set the MAC-ID of the new coupler in the DHCP server or BootP server after changing the Bus Coupler.

### Communication errors when online \*

After a period in the online state (logged in via Ethernet/AMS) the message *Communication error - logging out* always occurs.

The data traffic through the Ethernet interface is jamming.

Remedy:

- reduce the level of data communication.
- Stop the cyclical data traffic, or lengthen the task time.
- Reduce the number of windows open in the online display.
- Log in via the serial interface.

\* BC9000, IL230x-C900 only

## 7.4 ADS diagnostics

### Status inputs

It is possible to monitor the BK/BC9000, B/C900 Bus Coupler's communication in the system manager. Each Bus Coupler has status inputs that can be found in the hardware tree.

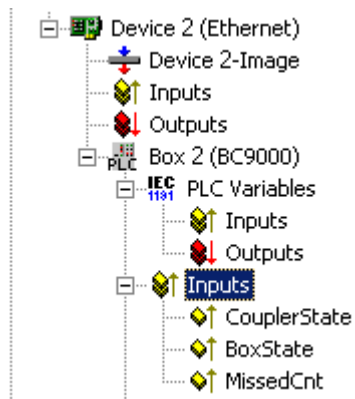

Fig. 33: Status inputs of the BC9000

### Coupler state

Value	Meaning
0x0000	No error
0x0001	Bus Terminal error; there is a K-bus error
0x0002	Configuration error; the parameterized configuration does not match the actual configuration

### MissedCnt

Ideal configuration:

The task time is always longer than the Ethernet transmission time. An Ethernet telegram is transmitted at the beginning of the task, and it returns it to the PC again after a period of time,  $t_{Eth}$ . If the time  $t_{Eth}$  is always smaller than the task time that has been set, the value in the *MissedCnt* counter remains constant.

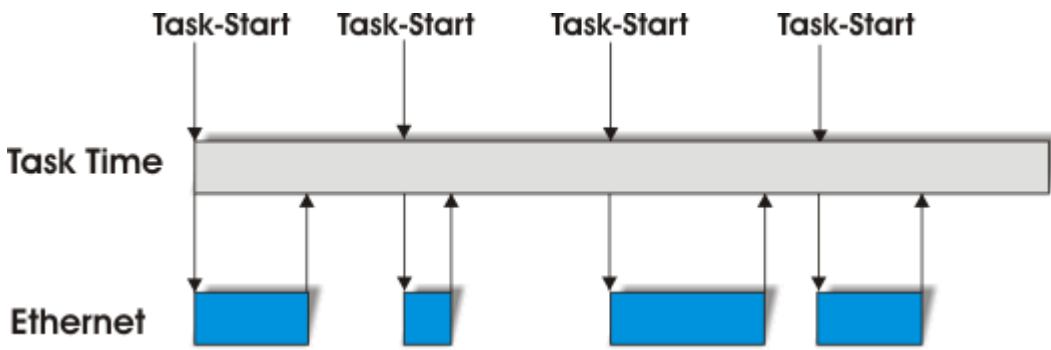

Fig. 34: Task time longer than Ethernet propagation delay

If, after the task time has elapsed, an Ethernet telegram has still not arrived at the PC, only reaching it after the next task has started, then TwinCAT will continue to work with the old input data. In addition, the *MissedCnt* counter is incremented.

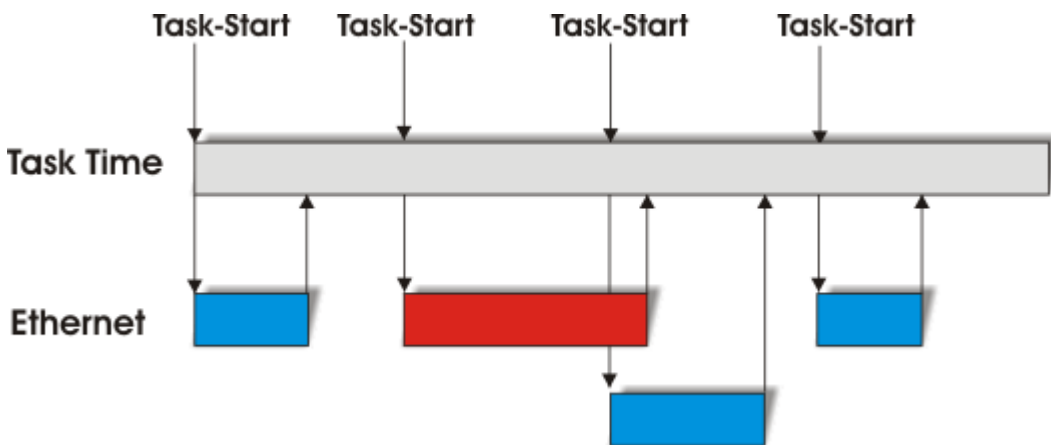

Fig. 35: Task time shorter than Ethernet propagation delay

This can have the following causes:

- The chosen task time is too short. Set
  - 100 ms or more for TCP.
  - 20 ms or more for UDP.
- Too many collisions in the network: use switches instead of hubs!
- The bus loading is too high: change to 100 MBaud!
- You are logged in to the BC9000, C900: this consumes additional processing capacity in the Controller, which lengthens the response time.

The two following diagnostic inputs have different meanings, depending on the transmission type.

**TCP/IP diagnosis**

**BoxState**

Value	Meaning
0x0000	No error
0x0001	No current inputs

**MissedCnt**

Value	Meaning
0xyyyy	Number of telegrams that have not returned in time for the start of the task. This value should remain almost constant. If the value keeps rising, the task time should be lengthened.

**UDP/IP diagnosis****BoxState**

Value	Meaning
0x0000	No error
0x0001	No current inputs
0x0002	Outputs are written as zero
0xxxxz	xx - warning level. The value here is incremented by one each time the data is not received in time. When data is exchanged correctly, the value is decremented by one. When the maximum warning level (default value 100) is reached, zero is written to the output data, and it is only enabled again for the normal process image when the warning level has reached zero.

**MissedCnt**

Value	Meaning
0xyyyy	Number of telegrams that have not returned in time for the start of the task. This value should remain almost constant. If the value keeps rising, the task time should be lengthened.

## 7.5 ModbusTCP diagnostic

- [See Modbus diagnostic function \[► 63\]](#)
- [See ModbusTCP error answers \[► 59\]](#)

## 8 Appendix

### 8.1 General operating conditions

The following conditions must be met in order to ensure flawless operation of the fieldbus components.

#### Environmental conditions

##### Operation

The components may not be used without additional protection in the following locations:

- in difficult environments, such as where there are corrosive vapors or gases, or high dust levels
- in the presence of high levels of ionizing radiation

Condition	Permissible range
Permissible ambient temperature during operation	see technical data
Installation position	variable
Vibration resistance	According to EN 60068-2-6
Shock resistance	According to EN 60068-2-27
EMC resistance	According to EN 61000-6-2
Emission	According to EN 61000-6-4

#### Transport and storage

Condition	Permissible range
Permissible ambient temperature during storage	-25 °C... +85 °C
Relative humidity	95 %, no condensation
Free fall	up to 1 m in the original packaging

#### Protection classes and types

Condition	Permissible range
Protection class in accordance with IEC 536 (VDE 0106, Part 1)	A protective conductor connection to the mounting rail is necessary!
Protection class conforms to IEC 529	IP20 (protection against contact with a standard test finger)
Protection against foreign objects	Less than 12 mm in diameter
Protection against water	no protection

#### Component identification

Every supplied component includes an adhesive label providing information about the product's approvals. For example, on the BK2000:

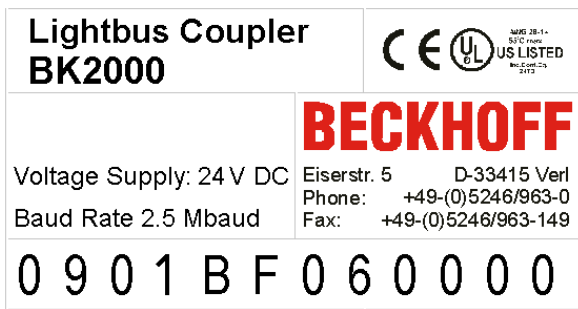

Fig. 36: Sticker with information about the BK2000 Bus Coupler certification

The following information is printed on the label:

Printed item	Meaning for this label
Precise product identification	Lightbus Coupler BK2000
Supply voltage	24 V <sub>DC</sub>
Data transfer rate	2.5 Mbit/s
Manufacturer	Beckhoff Automation GmbH
CE mark	Conformity mark
UL mark	Mark for UL approval. UL stands for the Underwriters Laboratories Inc., the leading certification Organisation for North America, based in the USA. C = Canada, US = USA, LISTED 22ZA (the test results can be inspected under this entry)
Production identification	From left to right, this sequence of characters indicates the week of production (2 characters), the year of production (2 characters), the software version (2 characters) and hardware version (2 characters), along with any special indications (4 characters).  This case therefore is a BK2000 - produced in the 9th calendar week - in the year 2001 - containing the BF firmware version - and using the 6th hardware version - with no special indications

## 8.2 Approvals

### Underwriter laboratories

UL E172151

### Conformity mark

CE

### Protection class

IP20 conforms to EN60529

## 8.3 Test standards for device testing

### EMC

EN 61000-6-2



EN 61000-6-4

### **Vibration resistance**

EN 60068-2-6 vibration test

EN 60068-2-27/29 shock test

## **8.4 Bibliography**

### **TCP/IP**

TCP/IP (German)

Aufbau und Betrieb eines TCP/IP Netzes (Structure and Operation of a TCP/IP Network)

by Kevin Washburn and Jim Evans

Publisher: ADDISON-WESLEY Longmann Verlag

TCP/IP (English)

Illustrated, Volume1 The Protocols

by W. Richard Stevens

Publisher: ADDISON-WESLEY Longmann Verlag

### **Modbus/TCP**

<http://www.modicon.com/>

<http://www.modbus.org>

### **TwinCAT**

BECKHOFF Information System

<http://infosys.beckhoff.com>

## **8.5 List of Abbreviations**

### **ADS**

Automation Device Specification

### **IP (20)**

Bus Terminal protection class

### **IPC**

Industrial PC

### **I/O**

Inputs and outputs

### **K-bus**

Terminal bus

### **KS2000**

Configuration software for Bus Terminals, Bus Couplers, Bus Terminal Controllers, fieldbus box modules, etc.

**PE**

The PE power contact can be used as a protective earth.

**TwinCAT**

The Windows Control and Automation Technology

## 8.6 Beckhoff Identification Code (BIC)

The Beckhoff Identification Code (BIC) is increasingly being applied to Beckhoff products to uniquely identify the product. The BIC is represented as a Data Matrix Code (DMC, code scheme ECC200), the content is based on the ANSI standard MH10.8.2-2016.

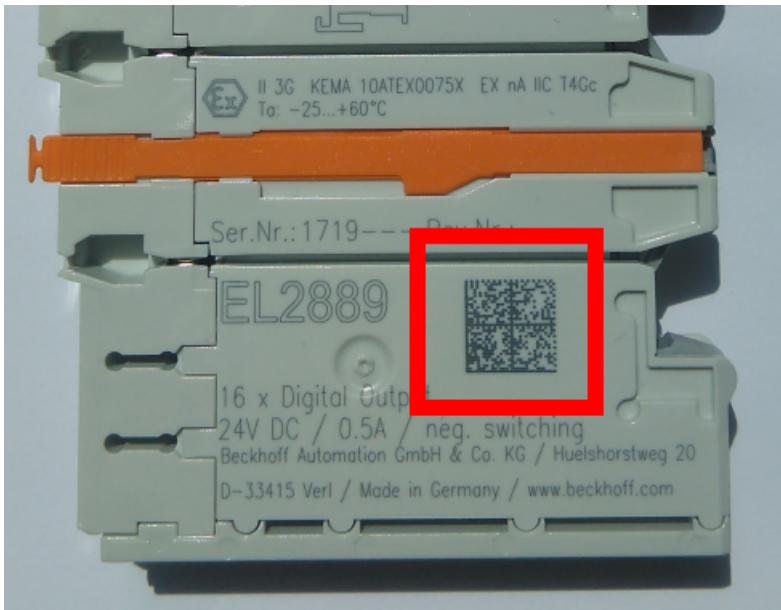

Fig. 37: BIC as data matrix code (DMC, code scheme ECC200)

The BIC will be introduced step by step across all product groups.

Depending on the product, it can be found in the following places:

- on the packaging unit
- directly on the product (if space suffices)
- on the packaging unit and the product

The BIC is machine-readable and contains information that can also be used by the customer for handling and product management.

Each piece of information can be uniquely identified using the so-called data identifier (ANSI MH10.8.2-2016). The data identifier is followed by a character string. Both together have a maximum length according to the table below. If the information is shorter, spaces are added to it.

Following information is possible, positions 1 to 4 are always present, the other according to need of production:

Position	Type of information	Explanation	Data identifier	Number of digits incl. data identifier	Example
1	Beckhoff order number	<b>Beckhoff order number</b>	1P	8	<b>1P</b> 072222
2	Beckhoff Traceability Number (BTN)	<b>Unique serial number, see note below</b>	SBTN	12	<b>SBTN</b> k4p562d7
3	Article description	<b>Beckhoff article description, e.g. EL1008</b>	1K	32	<b>1K</b> EL1809
4	Quantity	<b>Quantity in packaging unit, e.g. 1, 10, etc.</b>	Q	6	<b>Q</b> 1
5	Batch number	Optional: Year and week of production	2P	14	<b>2P</b> 401503180016
6	ID/serial number	Optional: Present-day serial number system, e.g. with safety products	51S	12	<b>51S</b> 678294
7	Variant number	Optional: Product variant number on the basis of standard products	30P	32	<b>30P</b> F971, 2*K183
...					

Further types of information and data identifiers are used by Beckhoff and serve internal processes.

**Structure of the BIC**

Example of composite information from positions 1 to 4 and with the above given example value on position 6. The data identifiers are highlighted in bold font:

**1P**072222**SBTN**k4p562d7**1K**EL1809 **Q**1 **51S**678294

Accordingly as DMC:



Fig. 38: Example DMC **1P**072222**SBTN**k4p562d7**1K**EL1809 **Q**1 **51S**678294

**BTN**

An important component of the BIC is the Beckhoff Traceability Number (BTN, position 2). The BTN is a unique serial number consisting of eight characters that will replace all other serial number systems at Beckhoff in the long term (e.g. batch designations on IO components, previous serial number range for safety products, etc.). The BTN will also be introduced step by step, so it may happen that the BTN is not yet coded in the BIC.

<b>NOTE</b>
This information has been carefully prepared. However, the procedure described is constantly being further developed. We reserve the right to revise and change procedures and documentation at any time and without prior notice. No claims for changes can be made from the information, illustrations and descriptions in this information.

## 8.7 Support and Service

Beckhoff and their partners around the world offer comprehensive support and service, making available fast and competent assistance with all questions related to Beckhoff products and system solutions.

### Beckhoff's branch offices and representatives

Please contact your Beckhoff branch office or representative for local support and service on Beckhoff products!

The addresses of Beckhoff's branch offices and representatives round the world can be found on her internet pages: [www.beckhoff.com](http://www.beckhoff.com)

You will also find further documentation for Beckhoff components there.

### Support

The Beckhoff Support offers you comprehensive technical assistance, helping you not only with the application of individual Beckhoff products, but also with other, wide-ranging services:

- support
- design, programming and commissioning of complex automation systems
- and extensive training program for Beckhoff system components

Hotline: +49 5246 963 157  
e-mail: [support@beckhoff.com](mailto:support@beckhoff.com)  
web: [www.beckhoff.com/support](http://www.beckhoff.com/support)

### Service

The Beckhoff Service Center supports you in all matters of after-sales service:

- on-site service
- repair service
- spare parts service
- hotline service

Hotline: +49 5246 963 460  
e-mail: [service@beckhoff.com](mailto:service@beckhoff.com)  
web: [www.beckhoff.com/service](http://www.beckhoff.com/service)

### Headquarters Germany

Beckhoff Automation GmbH & Co. KG

Hülshorstweg 20  
33415 Verl  
Germany

Phone: +49 5246 963 0  
e-mail: [info@beckhoff.com](mailto:info@beckhoff.com)  
web: [www.beckhoff.com](http://www.beckhoff.com)

# Table of figures

Fig. 1	BK9000, BK9050.....	10
Fig. 2	BK9100 .....	11
Fig. 3	The principle of the Bus Terminal .....	15
Fig. 4	Spring contacts of the Beckhoff I/O components.....	17
Fig. 5	BK9000, BK9100, BC9000, BC9020, BC9100, BC9120 - dimensions .....	18
Fig. 6	BK9050, BC9050 - dimensions .....	19
Fig. 7	Electrical isolation .....	23
Fig. 8	RJ45 connector (Western plug) .....	23
Fig. 9	Ethernet connection via hub or switch .....	23
Fig. 10	Direct Ethernet connection (crossover cable).....	24
Fig. 11	Ethernet layout in star topology.....	24
Fig. 12	Ethernet layout in linear topology.....	25
Fig. 13	Start-up behaviour of the Bus Coupler.....	31
Fig. 14	Network classes .....	33
Fig. 15	BK9000, BK9100, BC9000, BC9100.....	34
Fig. 16	BK9050 .....	34
Fig. 17	Configuration of the Beckhoff BootP server.....	36
Fig. 18	Testing the IP address using the Ping command.....	38
Fig. 19	Reading the connected Bus Couplers and Bus Terminals.....	41
Fig. 20	Setting the router memory.....	41
Fig. 21	The IP Address tab .....	43
Fig. 22	User Datagram Protocol (UDP).....	46
Fig. 23	Protocols running on top of TCP/IP and UDP/IP .....	46
Fig. 24	BK9000 tab .....	49
Fig. 25	IP address tab.....	50
Fig. 26	The ADS protocol as a transport layer within the TwinCAT system.....	51
Fig. 27	Structure of the ADS protocol .....	52
Fig. 28	Displaying the AMS routing table using the KS2000 configuration software .....	56
Fig. 29	ModbusTCP Protocol .....	57
Fig. 30	BC9000 LEDs .....	69
Fig. 31	BC9100 LEDs .....	70
Fig. 32	BK9050 LEDs.....	72
Fig. 33	Status inputs of the BC9000 .....	74
Fig. 34	Task time longer than Ethernet propagation delay .....	75
Fig. 35	Task time shorter than Ethernet propagation delay .....	75
Fig. 36	Sticker with information about the BK2000 Bus Coupler certification .....	78
Fig. 37	BIC as data matrix code (DMC, code scheme ECC200) .....	80
Fig. 38	Example DMC 1P072222SBTNk4p562d71KEL1809 Q1 51S678294 .....	81



More Information:  
[www.beckhoff.com/BKxxxx](http://www.beckhoff.com/BKxxxx)

Beckhoff Automation GmbH & Co. KG  
Hülshorstweg 20  
33415 Verl  
Germany  
Phone: +49 5246 9630  
[info@beckhoff.com](mailto:info@beckhoff.com)  
[www.beckhoff.com](http://www.beckhoff.com)

