

Operating Instructions | EN

# KL6904

TwinSAFE logic terminal with 4 fail-safe outputs

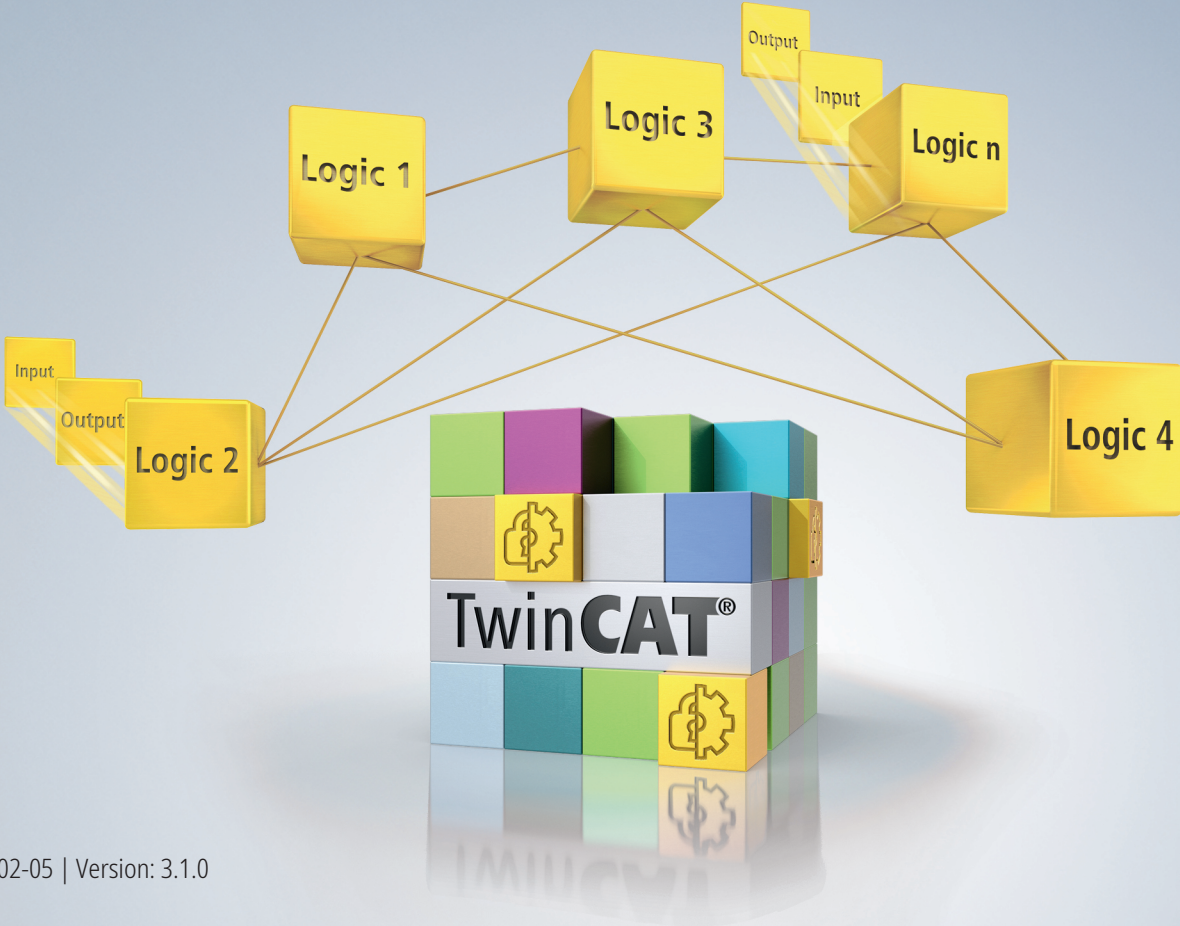



# Table of contents

<b>1</b>	<b>Notes on the documentation</b>	<b>5</b>
1.1	Disclaimer	5
1.1.1	Trademarks	5
1.1.2	Patents	5
1.1.3	Limitation of liability	6
1.1.4	Copyright	6
1.2	Documentation issue status	7
1.3	Staff qualification	8
1.4	Safety and instruction	9
1.5	Beckhoff Support and Service	10
<b>2</b>	<b>For your safety</b>	<b>11</b>
2.1	Duty of care	11
2.2	Safety image signs	12
2.3	General safety instructions	13
2.3.1	Before operation	13
2.3.2	During operation	13
2.3.3	After operation	13
<b>3</b>	<b>System description</b>	<b>14</b>
3.1	The Beckhoff Bus Terminal system	14
3.1.1	Bus Coupler	15
3.1.2	Bus Terminals	16
3.1.3	K-bus	17
3.1.4	Power contacts	17
3.2	TwinSAFE	18
3.2.1	The I/O construction kit is extended safely	18
3.2.2	Safety concept	18
3.2.3	KL1904, KL2904 – Bus Terminals with 4 fail-safe inputs or outputs	19
3.2.4	KL6904 TwinSAFE logic terminal with 4 fail-safe outputs	19
3.2.5	The fail-safe principle (Fail Stop)	19
<b>4</b>	<b>Product description</b>	<b>20</b>
4.1	KL6904 - TwinSAFE Terminal with 4 fail-safe outputs	20
4.2	Intended use	21
4.3	Technical data	22
4.4	Safety parameters	23
4.5	Dimensions	23
<b>5</b>	<b>Operation</b>	<b>24</b>
5.1	Environmental conditions	24
5.2	Installation	24
5.2.1	Safety instructions	24
5.2.2	Transport / storage	24
5.2.3	Mechanical installation	24
5.2.4	Electrical installation	26
5.3	Configuration of the terminal in TwinCAT	30

5.3.1	Configuration requirements.....	30
5.3.2	Inserting a Bus Coupler.....	30
5.3.3	Inserting a Bus Terminal .....	30
5.3.4	Inserting a KL6904 .....	30
5.3.5	Address settings on TwinSAFE terminals with 1023 possible addresses.....	33
5.3.6	Creating a TwinSAFE Group.....	33
5.3.7	TwinSAFE Group signals .....	36
5.3.8	Append a function block.....	37
5.3.9	KL6904 user and version administration.....	42
5.3.10	Loading the project into the KL6904 .....	43
5.3.11	Communication between TwinCAT controllers .....	45
<b>6</b>	<b>Diagnosis .....</b>	<b>49</b>
6.1	Diagnostic LEDs.....	49
6.1.1	Diag1 (green) .....	49
6.1.2	DIAG2 (red).....	49
6.1.3	Diag3 (red) and Diag4 (red) .....	50
<b>7</b>	<b>Service life .....</b>	<b>51</b>
<b>8</b>	<b>Maintenance and cleaning .....</b>	<b>52</b>
<b>9</b>	<b>Decommissioning .....</b>	<b>53</b>
9.1	Disposal .....	53
9.1.1	Returning to the vendor.....	53
<b>10</b>	<b>Appendix.....</b>	<b>54</b>
10.1	Volatility .....	54
10.2	Focus of certificates .....	55

# 1 Notes on the documentation

## 1.1 Disclaimer

Beckhoff products are subject to continuous further development. We reserve the right to revise the operating instructions at any time and without prior announcement. No claims for the modification of products that have already been supplied may be made on the basis of the data, diagrams and descriptions in these operating instructions.

In these operating instructions we define all permissible use cases whose properties and operating conditions we can guarantee. The use cases we define are fully tested and certified. Use cases beyond this, which are not described in these operating instructions, require the approval of Beckhoff Automation GmbH & Co KG.

### 1.1.1 Trademarks

Beckhoff®, TwinCAT®, EtherCAT®, EtherCAT G®, EtherCAT G10®, EtherCAT P®, Safety over EtherCAT®, TwinSAFE®, XFC®, XTS® and XPlanar® are registered and licensed trademarks of Beckhoff Automation GmbH.

The use of other brand names or designations by third parties may lead to an infringement of the rights of the owners of the corresponding designations.

### 1.1.2 Patents

The EtherCAT technology is protected by patent rights through the following registrations and patents with corresponding applications and registrations in various other countries:

- EP1590927
- EP1789857
- EP1456722
- EP2137893
- DE102015105702



EtherCAT® is a registered trademark and patented technology, licensed by Beckhoff Automation GmbH.



Safety over EtherCAT® is a registered trademark and patented technology, licensed by Beckhoff Automation GmbH.

### 1.1.3 Limitation of liability

All components in this product as described in the operating instructions are delivered in a specific configuration of hardware and software, depending on the application regulations. Modifications and changes to the hardware and/or software configuration that go beyond the documented options are prohibited and nullify the liability of Beckhoff Automation GmbH & Co. KG.

**The following is excluded from the liability:**

- Failure to observe these operating instructions
- Improper use
- Use of untrained personnel
- Use of unauthorized spare parts

### 1.1.4 Copyright

© Beckhoff Automation GmbH & Co. KG, Germany.

The distribution and reproduction of this document as well as the use and communication of its contents without express authorization are prohibited.

Offenders will be held liable for the payment of damages. All rights reserved in the event of the grant of a patent, utility model or design.

## 1.2 Documentation issue status

Version	Comment
3.1.0	<ul style="list-style-type: none"> <li>• Chapter <a href="#">Safety and instruction [► 9]</a> revised</li> <li>• In chapter <a href="#">Technical data [► 22]</a> corrosive gas test and footnote for corrosive environment added</li> <li>• Warning added in chapter <a href="#">Installation on mounting rails [► 25]</a></li> <li>• Chapter <a href="#">Service life [► 51]</a> revised</li> <li>• Certificate removed</li> </ul>
3.0.0	<ul style="list-style-type: none"> <li>• Migration</li> <li>• Foreword changed in <a href="#">Notes on the documentation [► 5]</a> and <a href="#">For your safety [► 11]</a></li> <li>• In chapter <a href="#">Technical data [► 22]</a> link to download page of certificates added</li> <li>• <a href="#">Maintenance and cleaning [► 52]</a> and <a href="#">Decommissioning [► 53]</a> added</li> <li>• Appendix adapted and extended</li> </ul>
2.2.1	<ul style="list-style-type: none"> <li>• Technical data for <i>permissible air pressure</i> extended</li> </ul>
2.2.0	<ul style="list-style-type: none"> <li>• Reliability document updated</li> <li>• Safety parameters updated</li> <li>• Foreword revised</li> </ul>
2.1.2	<ul style="list-style-type: none"> <li>• Reliability document updated</li> </ul>
2.1.1	<ul style="list-style-type: none"> <li>• Certificate updated</li> </ul>
2.1.0	<ul style="list-style-type: none"> <li>• Company address changed</li> <li>• Document origin added</li> <li>• Version history added</li> <li>• EN954 example removed</li> <li>• Safety parameters extended</li> </ul>
2.0.1	<ul style="list-style-type: none"> <li>• Reference to EN 60068-2-29 removed</li> </ul>
2.0.0	<ul style="list-style-type: none"> <li>• Description of the configuration in the TwinCAT System Manager added</li> <li>• Certificates added</li> <li>• Note on test pulses of the outputs added</li> <li>• Tested devices extended</li> </ul>
1.1.4	<ul style="list-style-type: none"> <li>• Diagrams corrected</li> <li>• Flashing codes corrected</li> </ul>
1.1.3	<ul style="list-style-type: none"> <li>• Pin assignment corrected</li> </ul>
1.1.2	<ul style="list-style-type: none"> <li>• Technical data updated</li> </ul>
1.1.1	<ul style="list-style-type: none"> <li>• LED and graphics updated</li> </ul>
1.1.0	<ul style="list-style-type: none"> <li>• Technical data extended</li> <li>• Editorial amendments</li> </ul>
1.0.3	<ul style="list-style-type: none"> <li>• Description of LEDs and flashing codes updated</li> <li>• TwinSAFE description updated</li> </ul>
1.0.2	<ul style="list-style-type: none"> <li>• Note relating to qualified software tool amended</li> </ul>
1.0.1	<ul style="list-style-type: none"> <li>• LoP list incorporated</li> </ul>
1.0.0	<ul style="list-style-type: none"> <li>• First release</li> </ul>

### Currentness

Please check whether you are using the current and valid version of this document. The current version can be downloaded from the Beckhoff homepage at <http://www.beckhoff.de/twinsafe>. In case of doubt, please contact Technical Support (see [Beckhoff Support and Service \[► 10\]](#)).

**Origin of the document**

The original documentation is written in German. All other languages are derived from the German original.

**Product features**

Only the product properties specified in the current operating instructions are valid. Further information given on the product pages of the Beckhoff homepage, in emails or in other publications is not authoritative.

## 1.3 Staff qualification

These operating instructions are intended exclusively for trained specialists in control technology and automation with the relevant knowledge.

The trained specialist personnel must ensure that the applications and use of the described product meet all safety requirements. This includes all applicable and valid laws, regulations, provisions and standards.

**Trained specialists**

Trained specialists have extensive technical knowledge from studies, apprenticeships or technical training. Understanding of control technology and automation is available. Trained specialists can:

- Independently identify, avoid and eliminate sources of hazard.
- Apply relevant standards and directives.
- Implement specifications from accident prevention regulations.
- Evaluate, prepare and set up the workplaces.
- Evaluate, optimize and execute work independently.



## 1.4 Safety and instruction

Read the contents that refer to the activities you have to perform with the product. Always read the chapter [For your safety \[▶ 11\]](#) in the operating instructions.

Observe the warnings in the chapters so that you can handle and work with the product as intended and safely.

### Explanation of symbols

Various symbols are used for a clear arrangement:

1. The numbering indicates an action that should be taken.
  - The bullet point indicates an enumeration.
- [...] The square brackets indicate cross-references to other text passages in the document.
- [1] The number in square brackets indicates the numbering of a referenced document.

The signal words used in the documentation are classified below.

### Signal words

#### Warning of personal injuries

##### **DANGER**

Hazard with high risk of death or serious injury.

##### **WARNING**

Hazard with medium risk of death or serious injury.

##### **CAUTION**

There is a low-risk hazard that could result in medium or minor injury.

#### Warning of damage to property or environment

##### **NOTICE**

##### **Notes**

The environment, equipment, or data may be damaged.

#### Information on handling the product



This information includes, for example:  
Recommendations for action, assistance or further information on the product.

## 1.5 Beckhoff Support and Service

### Support

Beckhoff Support offers technical advice on the use of individual Beckhoff products and system planning. The employees support you in the programming and commissioning of sophisticated automation systems.

Hotline: +49 5246/963-157  
E-mail: [support@beckhoff.com](mailto:support@beckhoff.com)  
Web: [www.beckhoff.com/support](http://www.beckhoff.com/support)

### Training

Training in Germany takes place in our training center at the Beckhoff headquarters in Verl, at subsidiaries or, by arrangement, at the customer's premises.

Hotline: +49 5246/963-5000  
E-mail: [training@beckhoff.com](mailto:training@beckhoff.com)  
Web: [www.beckhoff.com/training](http://www.beckhoff.com/training)

### Service

The Beckhoff Service Center supports you with after-sales services such as on-site service, repair service or spare parts service.

Hotline: +49 5246/963-460  
E-mail: [service@beckhoff.com](mailto:service@beckhoff.com)  
Web: [www.beckhoff.com/service](http://www.beckhoff.com/service)

### Download area

In the download area you can obtain product information, software updates, the TwinCAT automation software, documentation and much more.

Web: [www.beckhoff.com/download](http://www.beckhoff.com/download)

### Headquarters

Beckhoff Automation GmbH & Co. KG  
Hülshorstweg 20  
33415 Verl  
Germany

Phone: +49 5246/963-0  
E-mail: [info@beckhoff.com](mailto:info@beckhoff.com)  
Web: [www.beckhoff.com](http://www.beckhoff.com)

For the addresses of our worldwide locations, please visit our website at [Global Presence](#).

## 2 For your safety

Read this chapter containing general safety information. In addition, always observe the safety instructions and warnings in these operating instructions for your own safety, the safety of other persons and the safety of the product.

When working with control and automation products, many dangers can result from careless or incorrect use. Work particularly thoroughly, not under time pressure and responsibly towards other people.

### 2.1 Duty of care

---

#### Read entire documentation for TwinSAFE component

- TwinSAFE application manual
  - EL6910 TwinSAFE logic terminal operating manual
  - TwinSAFE Logic FB documentation manual
- 

The operator must comply with all the requirements and notes specified in these operating instructions in order to fulfill his duty of care. This includes in particular that you

- comply with the provisions defined in the chapter [Limitation of liability](#) [▶ 6].
- only operate the TwinSAFE component when it is in perfect working order.
- provide the operating instructions in a legible condition and complete at the place of use of the TwinSAFE component.
- do not remove the safety markings attached to the TwinSAFE component and maintain their legibility.



#### **No disposal in domestic waste**

Products marked with a crossed-out waste bin must not be disposed of with domestic waste. The device is considered waste electrical and electronic equipment when it is disposed of. Observe the national regulations for the disposal of waste electrical and electronic equipment.

## 2.2 Safety image signs

Beckhoff products feature safety pictograms, either on stickers or printed, which vary depending on the product. They serve to protect people and to prevent damage to the products. Safety pictograms may not be removed and must be legible for the user.

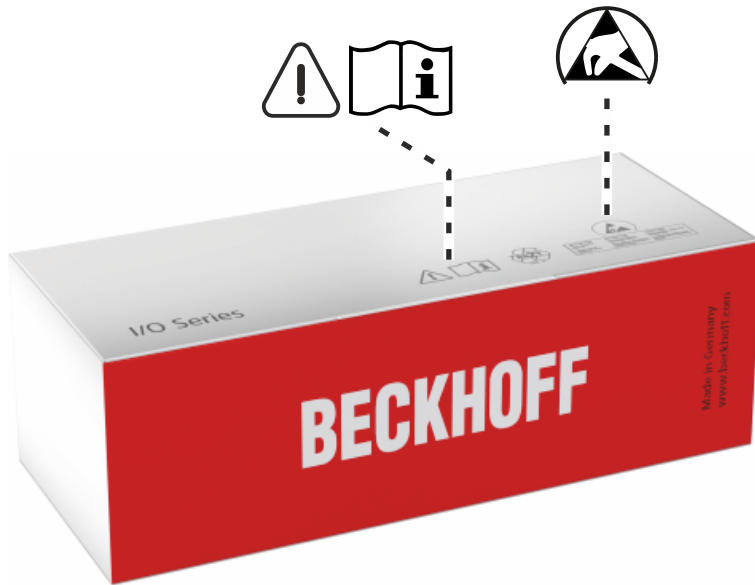

### **Read and observe the operating instructions**

Commissioning is only permitted if the operating instructions have been read and understood beforehand. This applies in particular to the safety instructions and the warnings.



### **Electrostatic sensitive components**

Work with and on the TwinSAFE component is only permitted at protected workplaces.

## 2.3 General safety instructions

### 2.3.1 Before operation

#### Use in machines according to the Machinery Directive

Only use the TwinSAFE component in machines that comply with the Machinery Directive. This is how you ensure safe operation.

#### Ensure traceability

Ensure the traceability of the TwinSAFE component via the serial number.

#### Carry out commissioning test

Before commissioning, wiring faults to the sensors must be excluded. Before commissioning, carry out a commissioning test. After a successful commissioning test, you can use the TwinSAFE component for the intended safety-related task.

In case of wiring errors, the safety function of the product is at risk. Depending on the machine, death and danger to life, serious bodily injury and damage to the machine may result.

### 2.3.2 During operation

#### Interference due to emitted interference

Do not operate the following devices in the vicinity of the TwinSAFE component: for example, radio telephones, radios, transmitters or high-frequency systems.

TwinSAFE components comply with the requirements of the applicable electromagnetic compatibility standards with regard to interference emission and immunity. If you exceed the limits for emitted interference specified in the standards, the function of the TwinSAFE component may be impaired.

### 2.3.3 After operation

#### De-energize and switch off components before working on them

Check all safety-relevant equipment for functionality before working on the TwinSAFE component. Secure the working environment. Secure the machine or plant against being inadvertently started up. Observe the chapter [Decommissioning](#) [► 53].

## 3 System description

### 3.1 The Beckhoff Bus Terminal system

The Beckhoff Bus Terminal system is used for decentralized connection of sensors and actuators to a control system. The Beckhoff Bus Terminal system components are mainly used in industrial automation and building management applications. In its minimum configuration, a bus station consists of a Bus Coupler or a Bus Terminal Controller and Bus Terminals connected to it. The Bus Coupler forms the communication interface to the higher-level controller, and the terminals are the interface to sensors and actuators. The whole bus station is clipped onto a 35 mm DIN mounting rail (EN 60715). The mechanical cross connection of the bus station is established via a slot and key system at the Bus Coupler and the Bus Terminals.

The sensors and actuators are connected with terminals via the screwless Cage Clamp® connection system.

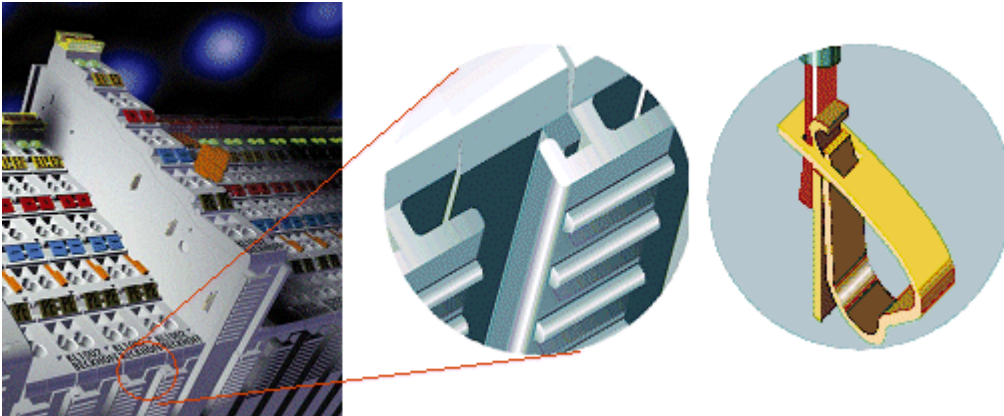

Fig. 1: Slot and key system and screwless (spring-loaded) connection system.

Since a wide range of different communication standards are established in industrial automation, Beckhoff offers Bus Couplers for all common bus systems (e.g. BK3120 for PROFIBUS, BK9000 for Ethernet, etc.).

### 3.1.1 Bus Coupler

Mechanical data	Bus coupler
Material	Polycarbonate, polyamide (PA6.6).
Dimensions (W x H x D)	47 mm x 100 mm x 68 mm
Installation	on 35 mm mounting rail (EN 60715) with locking
Attachable by	double slot and key connection

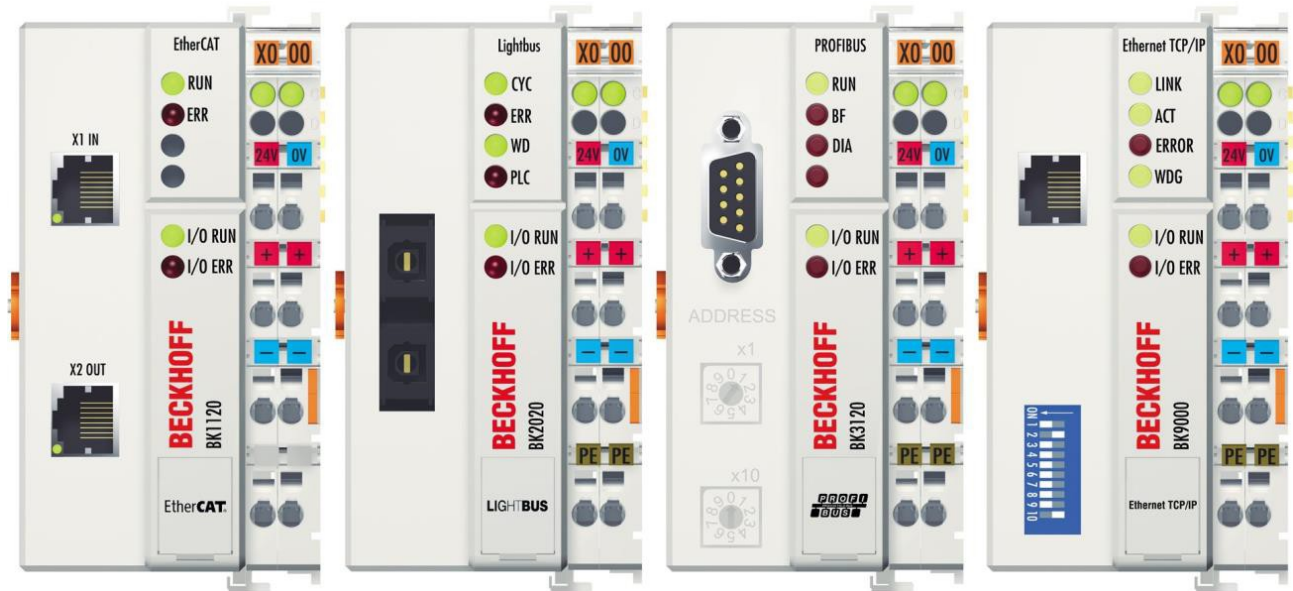

Fig. 2: Bus coupler

Connection technology	Bus Coupler
Wiring	cage Clamp® spring-loaded system
Connection cross-section	0.08 mm² ... 2.5 mm², stranded wire, solid wire
Fieldbus connection	depending on fieldbus
Power contacts	3 spring contacts
Current load	10 A
Rated voltage	24 V <sub>DC</sub>

### 3.1.2 Bus Terminals

Mechanical data	Bus Terminal
Material	polycarbonate, polyamide (PA6.6).
Dimensions (W x H x D)	12 mm x 100 mm x 68 mm or 24 mm x 100 mm x 68 mm
Mounting	on 35 mm mounting rail (EN 60715) with locking
Attachable by	double slot and key connection

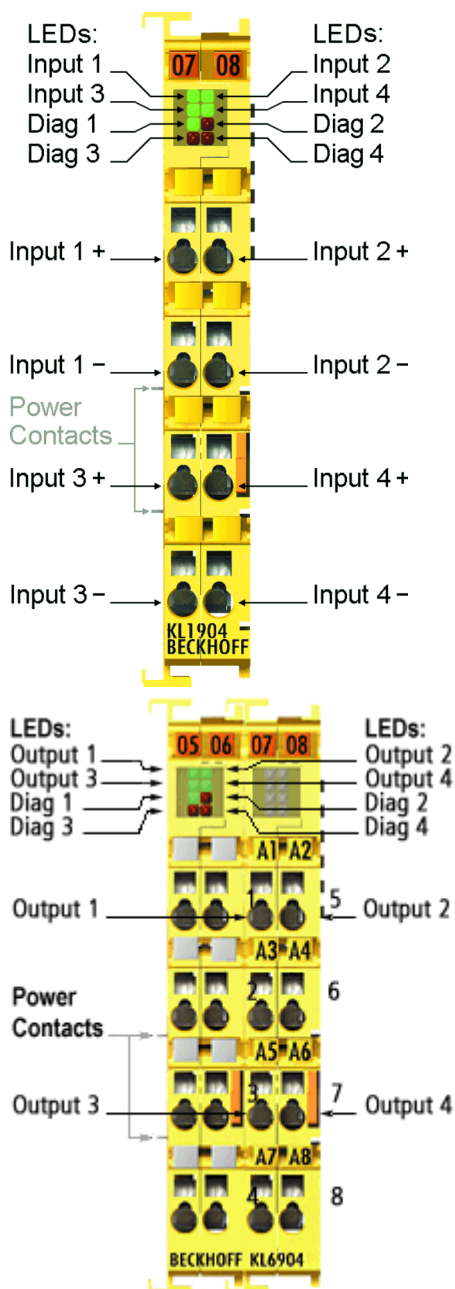

Fig. 3: TwinSAFE Terminals (EtherCAT)

Connection technology	Bus terminal
Wiring	Spring-loaded system (Cage Clamp®)
Connection cross-section	0.08 mm² ... 2.5 mm², stranded wire, solid wire
Fieldbus connection	Depending on fieldbus
Power contacts	Up to 3 blade/spring contacts
Current load	10 A
Nominal voltage	depends on bus terminal type



### **3.1.3 K-bus**

The K-bus is the data path within a terminal strip. The K-bus is led through from the bus coupler through all the terminals via six contacts on the terminals' side walls. The end terminal terminates the K-bus.

### **3.1.4 Power contacts**

The operating voltage is passed on to following terminals via three power contacts. Terminal strip can be split into galvanically isolated groups by means of potential feed terminals as required. The power feed terminals play no part in the control of the terminals and can be inserted at any locations within the terminal strip.

## 3.2 TwinSAFE

### 3.2.1 The I/O construction kit is extended safely

With the TwinSAFE Terminals, Beckhoff offers the option of simply expanding the proven bus terminal system, and to transfer the complete cabling for the safety circuit into the already existing fieldbus cable. Safe signals can be mixed with standard signals without restriction. This saves design effort, installation and material. Maintenance is simplified significantly through faster diagnosis and simple replacement of only a few components.

The new KLx9xx series Bus Terminals only include three basic functionalities: digital KL19xx inputs, digital KL29xx outputs and a KL6904 link unit. For a large number of applications, all sensors and actuators can be wired on these bus terminals. The required logic link of the inputs and the outputs is handled by the KL6904. For small to medium-sized configurations, the tasks of a fail-safe PLC can thus be handled within the bus terminal system.

### 3.2.2 Safety concept

#### **TwinSAFE: Safety and I/O technology in one system**

- Extension of the familiar Beckhoff I/O system with TwinSAFE Terminals
- Freely selectable mix of safe and standard signals
- Logic link of the I/Os in the KL6904 TwinSAFE logic terminal
- Safety-relevant networking of machines via bus systems

#### **TwinSAFE protocol (FSoE)**

- Transfer of safety-relevant data via any media (“genuine black channel”)
- TwinSAFE communication via fieldbus systems such as EtherCAT, Lightbus, PROFIBUS or Ethernet
- IEC 61508:2010 SIL 3 compliant

#### **Configuring instead of wiring: the TwinSAFE Configurator**

- Configuration of the TwinSAFE system via the TwinCAT System Manager
- System Manager for editing and displaying all bus parameters
- Certified function blocks such as Emergency Stop, Operation Mode, etc.
- Simple handling
- Typical function blocks for machine safety
- Freely selectable fieldbus connection with the KL6904 TwinSAFE logic terminal

#### **KL6904 TwinSAFE logic Bus Terminal**

- Link unit between TwinSAFE input and output terminals
- Configuration of a simple, flexible, cost-effective, decentralized safety controller
- No safety requirements for higher-level control system
- TwinSAFE enables networks with up to 1023 TwinSAFE devices.
- TwinSAFE Logic Terminal can establish up to 15 connections (TwinSAFE connections).
- Several TwinSAFE Logic Terminals are cascadable in a network
- Safety functions such as emergency stop, protective door, etc. are already included
- Suitable for applications up to SIL 3 according to IEC 61508:2010.

#### **TwinSAFE digital input (KL1904) and output terminal (KL2904)**

- All current safety sensors can be connected
- Operation with a TwinSAFE Logic Terminal

- KL1904 with 4 fail-safe inputs for sensors (24 VDC) with potential-free contacts
- KL2904 with four safe channels for actuators (24 VDC, 0.5 A per channel)
- conforming to IEC 61508:2010 SIL 3.

### **3.2.3 KL1904, KL2904 – Bus Terminals with 4 fail-safe inputs or outputs**

The KL1904 and KL2904 Bus Terminals enable connection of common safety sensors and actuators. They are operated with the KL6904 TwinSAFE logic terminal. The TwinSAFE Logic Terminal is the link unit between the TwinSAFE input and output terminals. It enables the configuration of a simple, flexible and cost-effective decentralized safety control system.

Therefore, there are no safety requirements for the higher-level control system! The typical safety functions required for the automation of machines, such as emergency stop, protective door, two-hand etc., are already permanently programmed in the KL6904. The user configures the KL6904 terminal according to the safety requirements of his application.

### **3.2.4 KL6904 TwinSAFE logic terminal with 4 fail-safe outputs**

The KL6904 TwinSAFE logic terminal is a digital output terminal with four fail-safe outputs with 0.5 A, 24 VDC. The KL6904 meets the requirements of IEC 61508:2010 SIL 3 and DIN EN ISO 13849-1:2006 (Cat 4, PL e).

### **3.2.5 The fail-safe principle (Fail Stop)**

The basic rule for a safety system such as TwinSAFE is that failure of a part, a system component or the overall system must never lead to a dangerous condition. The safe state is always the switched off and wattless state.

## 4 Product description

### 4.1 KL6904 - TwinSAFE Terminal with 4 fail-safe outputs

The KL6904 is a safe small controller with digital outputs for connecting actuators (contactors, relays, etc.) with a maximum current 0.5 A (24 VDC). The bus terminal has 4 fail-safe outputs.

The KL6904 meets the requirements of IEC 61508:2010 SIL 3, DIN EN ISO 13849-1:2006 (Cat 4, PL e), NRTL, UL508, UL1998 and UL991.

The TwinSAFE Terminal has the standard design of a Beckhoff Bus Terminal.

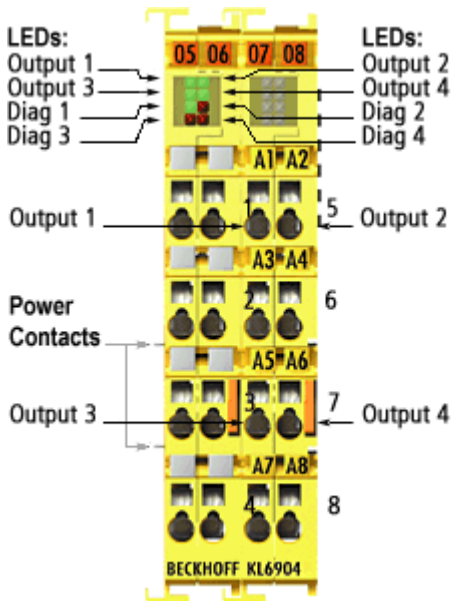

Fig. 4: KL6904

## 4.2 Intended use

### ⚠ WARNING

#### Caution - Risk of injury!

TwinSAFE components shall only be used for the purposes described below!

The TwinSAFE terminals expand the application range of Beckhoff Bus Terminal system with functions that enable them to be used for machine safety applications. The TwinSAFE terminals are designed for machine safety functions and directly associated industrial automation tasks. They are therefore only approved for applications with a defined fail-safe state. This safe state is the wattless state. Fail-safety according to the relevant standards is required.

The TwinSAFE Terminals enable connection of:

- 24 V<sub>DC</sub> sensors (KL1904) such as emergency stop push buttons, rope pull switches, position switches, two hand switches, safety switching mats, light curtains, light barriers, laser scanners, etc.
- 24 V<sub>DC</sub> actuators (KL2904) such as contactors, protective door switches with tumbler, signal lamps, servo drives, etc.

#### ● Test pulses



When selecting actuators please ensure that the KL6904 test pulses do not lead to actuator switching or diagnostic message from the KL6904.

The test pulses of the KL6904 terminal outputs are not configurable and cannot be switched off.

The following modules were developed for these tasks:

- The KL1904 terminal is an input module with digital inputs.
- The KL2904 terminal is an output module with digital outputs.
- The KL6904 terminal is a logic module with digital outputs.

These modules are suitable for operation with

- Beckhoff BKxxxx series Bus Couplers
- Beckhoff Bus Terminal Controllers of the BXxxxx series (with firmware version  $\geq 1.20$ ) (Beckhoff Bus Terminal Controllers of the BCxxxx series are not supported!)
- Beckhoff CXxxxx series Embedded PCs with K-bus connection

### ⚠ CAUTION

#### Follow the machinery directive!

The TwinSAFE components shall only be used in machines as defined in the machinery directive.

### ⚠ CAUTION

#### Ensure traceability!

The buyer has to ensure the traceability of the device via the serial number.

## 4.3 Technical data

The current certificates of all TwinSAFE products with the underlying standards and directives can be found at <https://www.beckhoff.com/en-en/support/download-finder/certificates-approvals/>.

Property	KL6904	
Number of inputs	0	
Number of outputs	4 (one green LED per output)	
Fault reaction time	≤ watchdog time	
Output current per channel	Min. 20 mA, max. 500 mA	
Cable length between sensor and terminal	unshielded	Max. 100 m
	shielded	Max. 100 m
Wire cross-section	Min. 0.75 mm <sup>2</sup>	
Input process image	Max. 192 bytes	
Output process image	Max. 192 bytes	
KL6904 supply voltage	24 V <sub>DC</sub> (−15% / +20%)	
Current consumption via K-bus	maximum 250 mA	
Power loss of the terminal	typically 2 W	
Electrical isolation (between the channels)	no	
Electrical isolation (between the channels and the E-bus)	yes	
Insulation voltage (between the channels and the K-bus, under common operating conditions)	Insulation tested with 500 V <sub>DC</sub>	
Dimensions (W x H x D)	24 mm x 100 mm x 68 mm	
Weight	approx. 100 g	
Permissible ambient temperature (operation)	0 °C to +55 °C	
Permissible ambient temperature (transport/storage)	−25 °C to +70 °C	
Permissible air humidity	5% ... 95%, non-condensing	
Permissible air pressure (operation/storage/transport)	750 hPa ... 1100 hPa (this is equivalent to an altitude of approx. −690 m to 2450 m above sea level assuming an international standard atmosphere)	
Climate category according to EN 60721-3-3	3K3	
Permissible degree of pollution conforms to EN 60664-1	2 (see chapter <a href="#">Maintenance and cleaning</a> [▶ 52])	
Inadmissible operating conditions	TwinSAFE Terminals must not be used under the following operating conditions: <ul style="list-style-type: none"> <li>• under the influence of ionizing radiation (exceeding the natural background radiation)</li> <li>• in corrosive environments<sup>1</sup></li> <li>• in an environment that leads to unacceptable soiling of the bus terminal</li> </ul>	
EMC immunity / emission	conforms to EN 61000-6-2 / EN 61000-6-4	
Vibration / shock resistance	conforms to EN 60068-2-6 / EN 60068-2-27	
Shocks	15 g with pulse duration 11 ms in all three axes	
Corrosive gas test	According to DIN EN 60068-2-60:2016-06, method 4 with increased concentrations according to ANSI/ISA 71.04:2013 Level GX Group A <ul style="list-style-type: none"> <li>• Test duration: 21 days</li> <li>• Hydrogen sulfide: (50 ± 5) ppb</li> <li>• Nitrogen dioxide: (1250 ± 20) ppb</li> <li>• Chlorine: (10 ± 5) ppb</li> <li>• Sulfur dioxide: (300 ± 20) ppb</li> </ul>	
Protection rating	IP20	
Permitted operating environment	In the control cabinet or terminal box, with minimum protection rating IP54 according to IEC 60529	
Permissible installation position	horizontal	

<sup>1</sup> A corrosive environment exists when corrosion damage becomes apparent.

## 4.4 Safety parameters

Key data	KL6904
Lifetime [a]	20
Proof test Interval [a]	not required <sup>1</sup>
PFH <sub>D</sub>	1.73E-09
%SIL 3	1.7%
PFD	1.42E-04
%SIL 3	14.2 %
MTTF <sub>D</sub>	high
DC	high
Performance Level	PL e
Category	4
HFT	1
Classification element <sup>2</sup>	Type B

<sup>1</sup> Special proof tests are not required during the entire service life of the EtherCAT Terminal.

<sup>2</sup> Classification according to IEC 61508-2:2010 (chapter 7.4.4.1.2 and 7.4.4.1.3)

The bus terminal can be used for safety-related applications within the meaning of IEC 61508:2010 up to SIL 3 and EN ISO 13849-1 up to PL e (Cat4).

For the calculation or estimation of the MTTFd value from the PFHD value, further information can be found in the TwinSAFE Application Guide or in ISO 13849-1:2015 Table K.1.

## 4.5 Dimensions

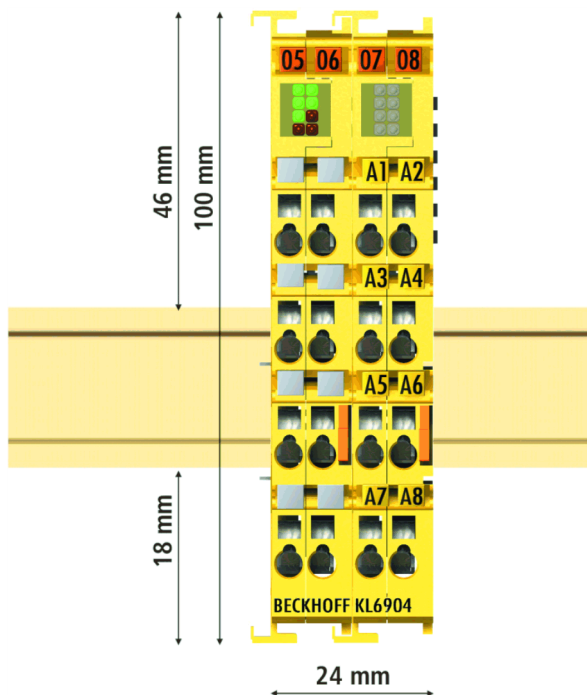

Fig. 5: Dimensions

Width: 24 mm (side-by-side installation)

Height: 100 mm

Depth: 68 mm

## 5 Operation

### 5.1 Environmental conditions

Please ensure that the TwinSAFE components are only transported, stored and operated under the specified conditions (see technical data)!

#### **WARNING**

##### **Risk of injury!**

The TwinSAFE components must not be used under the following conditions.

- under the influence of ionizing radiation (exceeding the natural background radiation)
- in corrosive environments
- in an environment that leads to unacceptable contamination of the TwinSAFE component

### 5.2 Installation

#### 5.2.1 Safety instructions

Before installing and commissioning the TwinSAFE components please read the safety instructions in the foreword of this documentation.

#### 5.2.2 Transport / storage

Use the original packaging in which the components were delivered for transporting and storing the TwinSAFE components.

#### **CAUTION**

##### **Note the specified environmental conditions**

Please ensure that the digital TwinSAFE components are only transported and stored under the specified environmental conditions (see technical data).

#### 5.2.3 Mechanical installation

#### **WARNING**

##### **Risk of injury!**

Bring the bus system into a safe, de-energized state before starting installation, disassembly or wiring of the devices!



### 5.2.3.1 Control cabinet / terminal box

The TwinSAFE terminals must be installed in a control cabinet or terminal box with IP54 protection class according to IEC 60529 as a minimum.

### 5.2.3.2 Installation on mounting rails

**⚠ WARNING**

**Risk of electric shock and damage of device!**  
 Bring the bus terminal system into a safe, powered down state before starting installation, disassembly or wiring of the Bus Terminals!

#### Installation

**NOTICE**

**Material damage due to improper installation**  
 Pressing on the LED strip can damage the TwinSAFE component and impair the function of the LEDs.

- Do not press on the LED strip when pushing the TwinSAFE component against the mounting rail. Instead, grasp the TwinSAFE component at the top and bottom edge or at the height of the orange tab to slide it onto the mounting rail.

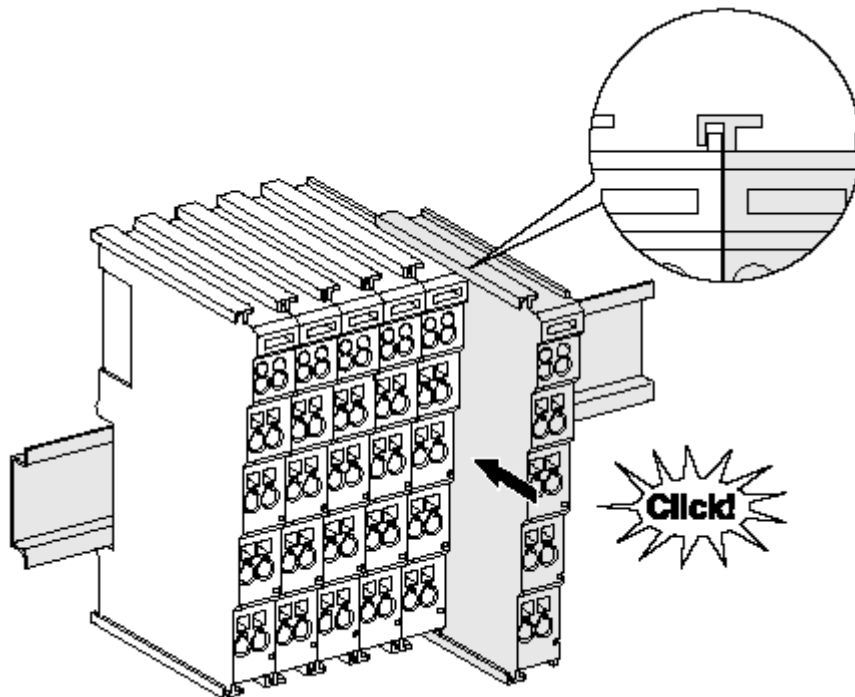

Fig. 6: Installation on the mounting rail

The bus couplers and bus terminals are attached to commercially available 35 mm mounting rails (DIN rail according to EN 60715) by applying slight pressure:

1. First attach the fieldbus coupler to the mounting rail.
2. The bus terminals are now attached on the right-hand side of the fieldbus coupler. To do this, plug the components together with tongue and groove and push the terminals against the mounting rail until the latch audibly engages on the mounting rail.  
 If you first snap the terminals onto the mounting rail and then push them next to each other without the tongue and groove interlocking, no functional connection will be established! When correctly assembled, no significant gap should be visible between the housings.

## **i** Fastening of mounting rails

The locking mechanism of the terminals and couplers protrudes into the profile of the mounting rail. When installing the components, make sure that the locking mechanism doesn't come into conflict with the fixing bolts of the mounting rail. For fastening mounting rails with a height of 7.5 mm under the terminals and couplers, use flat fastening components such as countersunk head screws or blind rivets.

## Disassembly

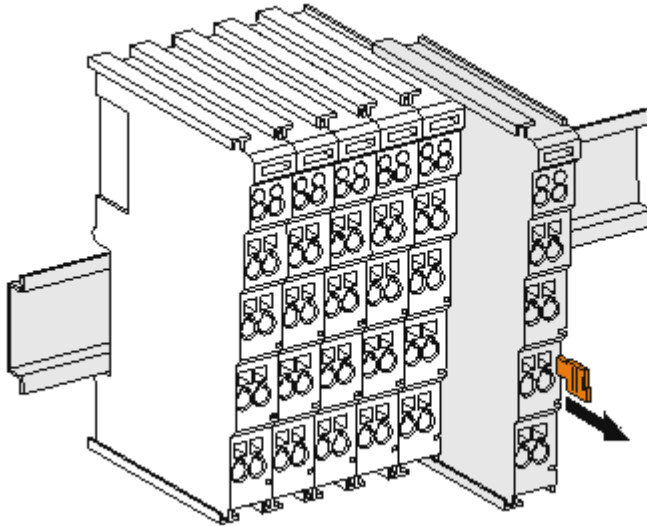

Fig. 7: Removal from mounting rail

Each terminal is secured by a lock on the mounting rail, which must be released for disassembly:

1. Pull down the terminal at its orange-colored straps from the mounting rail by approx. 1 cm. The rail locking of this terminal is automatically released, and you can now pull the terminal out of the Bus Terminal block with little effort.
2. To do this, grasp the unlocked terminal simultaneously at the top and bottom of the housing surfaces with your thumb and index finger and pull it out of the Bus Terminal block.

## 5.2.4 Electrical installation

### 5.2.4.1 Connections within a Bus Terminal block

The electric connections between the Bus Coupler and the Bus Terminals are automatically realized by joining the components:

#### Spring contacts (K-bus)

The six spring contacts of the K-bus deal with the transfer of the data and the supply of the bus terminal electronics.

### NOTICE

#### Observe the E-bus current

Observe the maximum current that your bus coupler can supply to the K-bus! Use the KL9400 Power Supply Terminal if the current consumption of your terminals exceeds the maximum current that your bus coupler can feed to the K-bus supply.

#### Power contacts

The power contacts deal with the supply for the field electronics and thus represent a supply rail within the bus terminal block. The power contacts are supplied via terminals on the bus coupler.

### **i** Note the connection of the power contacts

During the design of a bus terminal block, the pin assignment of the individual bus terminals must be taken account of, since some types (e.g. analog bus terminals or digital 4-channel bus terminals) do not or not fully loop through the power contacts.

Power supply terminals (KL91xx, KL92xx) interrupt the power contacts and thus represent the start of a new supply rail.

### PE power contact

The power contact labelled PE can be used as a protective earth. For safety reasons this contact mates first when plugging together, and can ground short-circuit currents of up to 125 A.

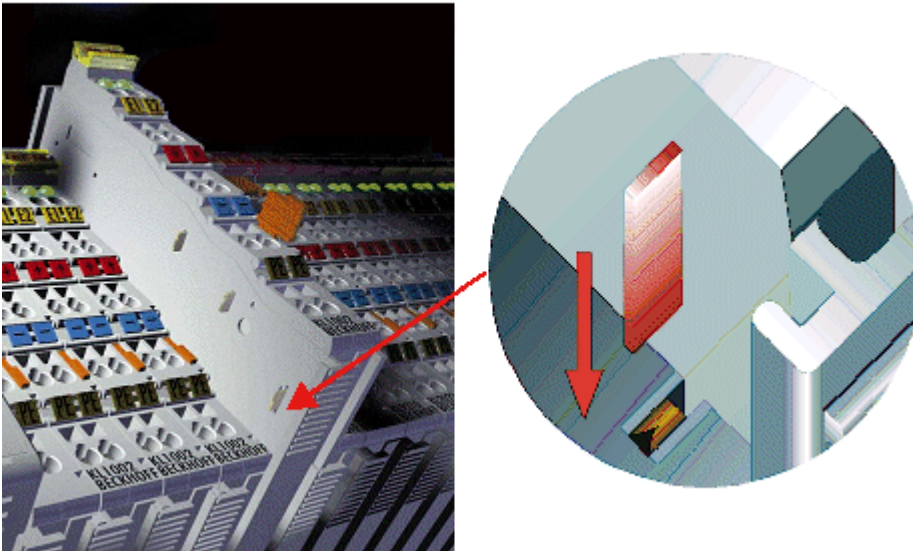

Fig. 8: PE power contact

#### **⚠ CAUTION**

##### **Insulation tests**

Note that, for reasons of electromagnetic compatibility, the PE contacts are capacitatively coupled to the mounting rail. This may lead to incorrect results during insulation testing or to damage on the terminal (e.g. disruptive discharge to the PE line during insulation testing of a consumer with a nominal voltage of 230 V). For insulation testing, disconnect the PE supply line at the Bus Coupler or the Power Feed Terminal! In order to decouple further feed points for testing, these Power Feed Terminals can be released and pulled at least 10 mm from the group of terminals.

#### **⚠ DANGER**

##### **Serious risk of injury!**

The PE power contact must not be used for other potentials!

### 5.2.4.2 Overvoltage protection

If protection against overvoltage is necessary in your plant, provide a surge filter for the voltage supply to the Bus Terminal blocks and the TwinSAFE terminals.

### 5.2.4.3 Wiring

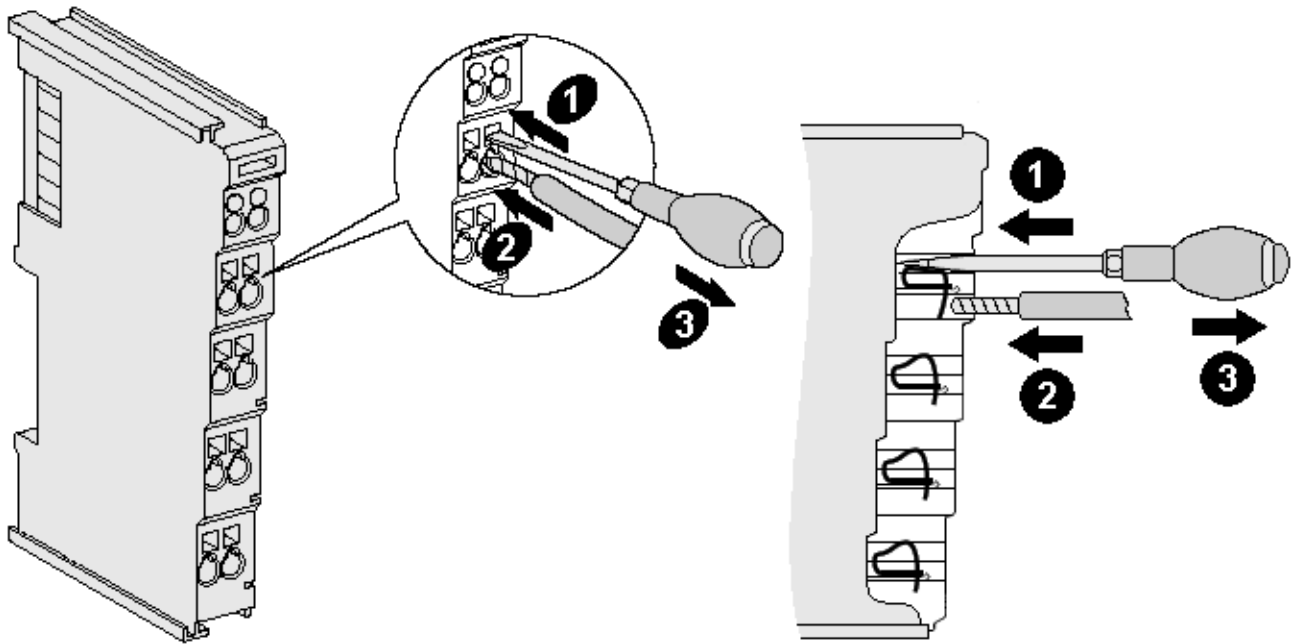

Fig. 9: Connection of a cable to a terminal point

Up to eight terminal points enable the connection of solid or finely stranded cables to the Bus Terminal. The terminal points are implemented in spring force technology. Connect the cables as follows:

1. Open a terminal point by pushing a screwdriver straight against the stop into the square opening above the terminal point. Do not turn the screwdriver or move it alternately (don't toggle).
2. The wire can now be inserted into the round terminal opening without any force.
3. The terminal closes automatically when the pressure is released, holding the wire safely and permanently.

The permissible conductor cross-sections can be taken from the following table.

<b>Wire cross-section</b>	0.08 ... 2.5 mm <sup>2</sup>
<b>Strip length</b>	8 ... 9 mm

5.2.4.4

Connection

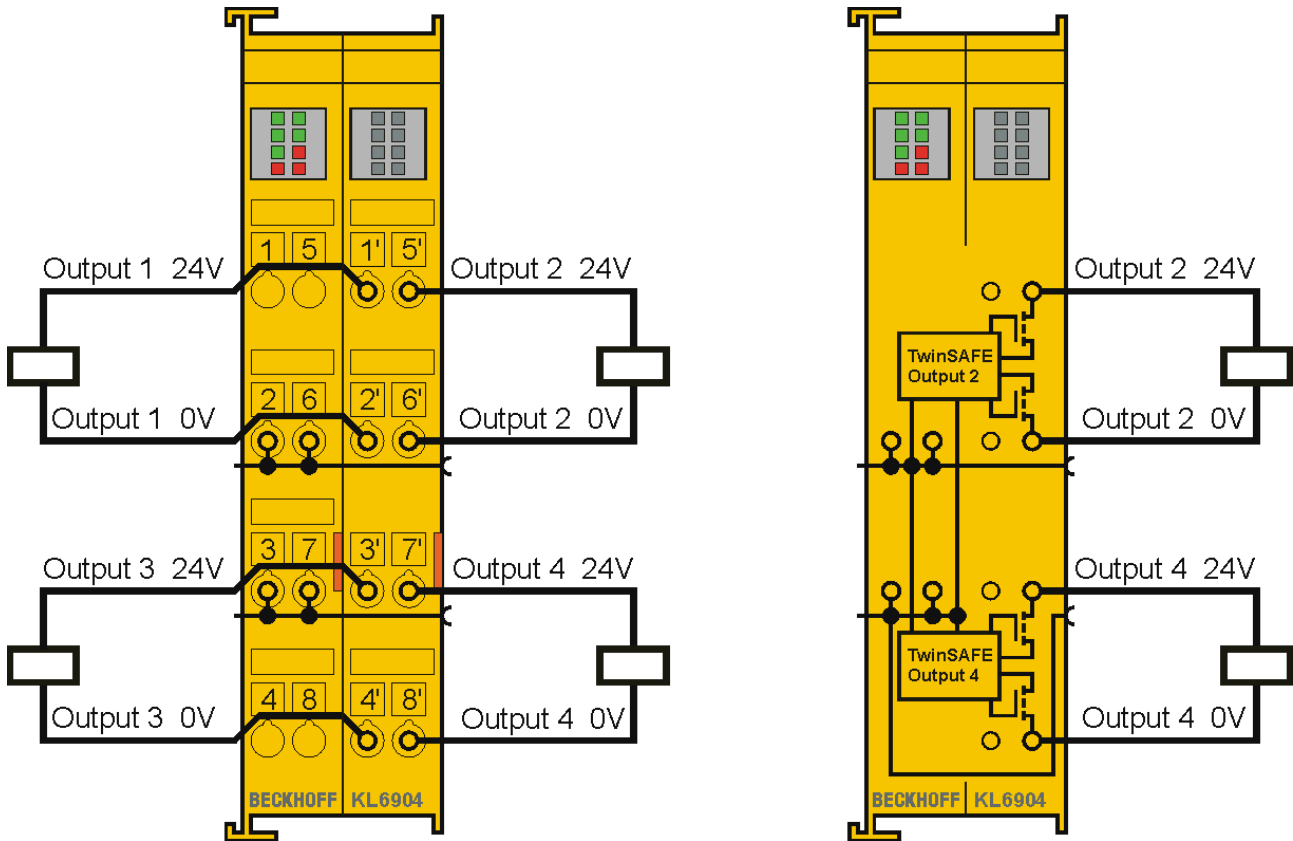

Fig. 10: KL6904 pin assignment

Terminal point	Output	Signal
1	-	not used, no function
2	-	positive power contact
3	-	negative power contact
4	-	not used, no function
5	-	not used, no function
6	-	positive power contact
7	-	negative power contact
8	-	not used, no function
1'	1	Output 1+
2'	1	Output 1-
3'	2	Output 3+
4'	2	Output 3-
5'	3	Output 2+
6'	3	Output 2-
7'	4	Output 4+
8'	4	Output 4-

**i Test pulses**

When selecting actuators please ensure that the KL6904 test pulses do not lead to actuator switching or diagnostic message from the KL6904.

The test pulses of the KL6904 terminal outputs are not configurable and cannot be switched off.

### 5.2.4.5 Tested devices

The following list contains devices that were tested together with the KL2904 TwinSAFE terminal. The results only apply for the current device hardware version at the time of testing. The tests were carried out in a laboratory environment. Modifications of these products cannot be considered here. If you are unsure please test the hardware together with the TwinSAFE terminal.

Vendor	Type	Comment
Beckhoff	C4000	TwinSAFE drive option card: safe restart lock
Beckhoff	S3000	safe restart lock
Beckhoff	SG2-14ISO45C1	3-channel contact extension with feedback
Siemens	lumiflex ROBUST 42/43/44	Contactora
Telemecanique	BNS250-11ZG	Contactora
Dold	GM701S	Extension module with potential-free contacts

The tests were carried out as function tests only. The information provided in the respective manufacturer documentation remains valid.

#### NOTICE

##### Recommended protective circuits

We recommend R/C or diode-based protective circuits for these devices. Varistor-based protective circuits should not be used.

## 5.3 Configuration of the terminal in TwinCAT

#### ⚠ CAUTION

##### Do not change the register values!

Do not change the register values for the TwinSAFE terminals. Changes to the register values (e.g. with the KS2000 configuration software or via register communication) sets the terminal permanently in the Fail-Stop state!

### 5.3.1 Configuration requirements

Version 2.10 build 1302 or higher of the TwinCAT automation software is required for configuring the KL6904. The latest version is available for download from the Beckhoff website at [www.beckhoff.de](http://www.beckhoff.de). In addition, the TwinSAFE Verifier must be installed. This is available on the Beckhoff Products & Solutions CD. The current installation can also be obtained from Beckhoff Support, if required.

Once the TwinSAFE Verifier was installed successfully, the TwinSAFE Verifier tab is available in the TwinCAT System Manager (further information can be found in section Loading the project into the KL6904).

### 5.3.2 Inserting a Bus Coupler

See TwinCAT automation software documentation.

### 5.3.3 Inserting a Bus Terminal

See TwinCAT automation software documentation.

### 5.3.4 Inserting a KL6904

A KL6904 is inserted in the same way as any other Beckhoff Bus Terminal. In the list open Safety Terminals (KLx9xx) and select the KL6904. The KL6904 can be selected with 7 or 15 TwinSAFE connections.

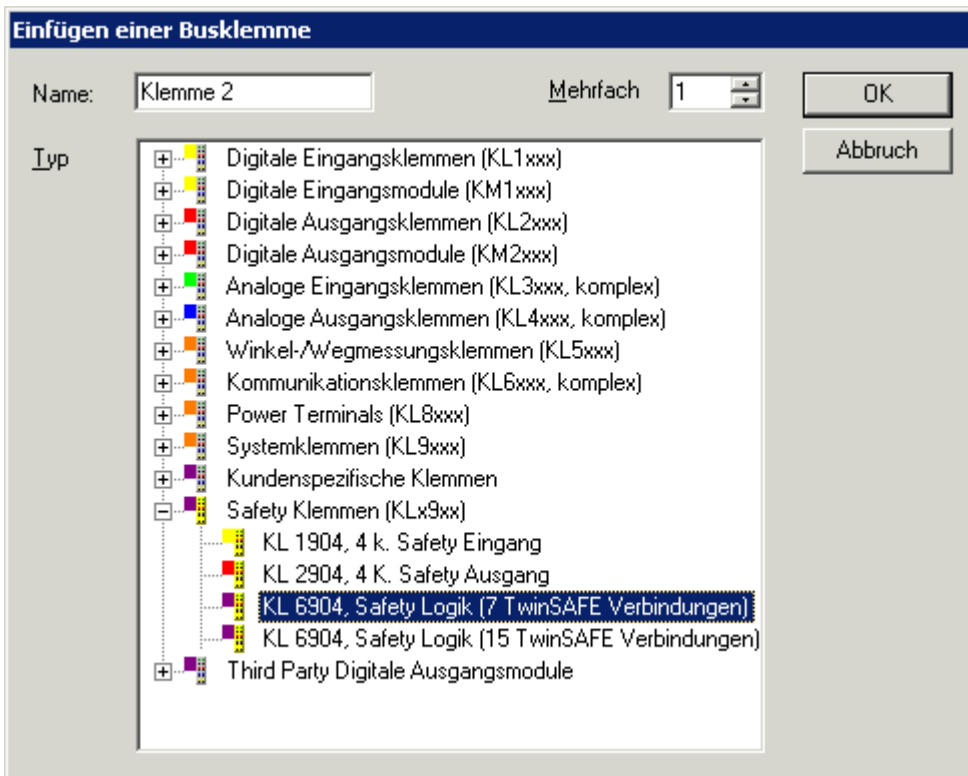

Fig. 11: Inserting a KL6904

**NOTICE**

**Size of the process image**

The process image should not be unnecessarily large.

If a KL6904 with 15 TwinSAFE connections is inserted, the KL6904 must be configured accordingly, since the KL6904 is delivered with 7 configured connections. The KL6904 can be configured with the KS2000 configuration software from Beckhoff (firmware version 14 or higher).

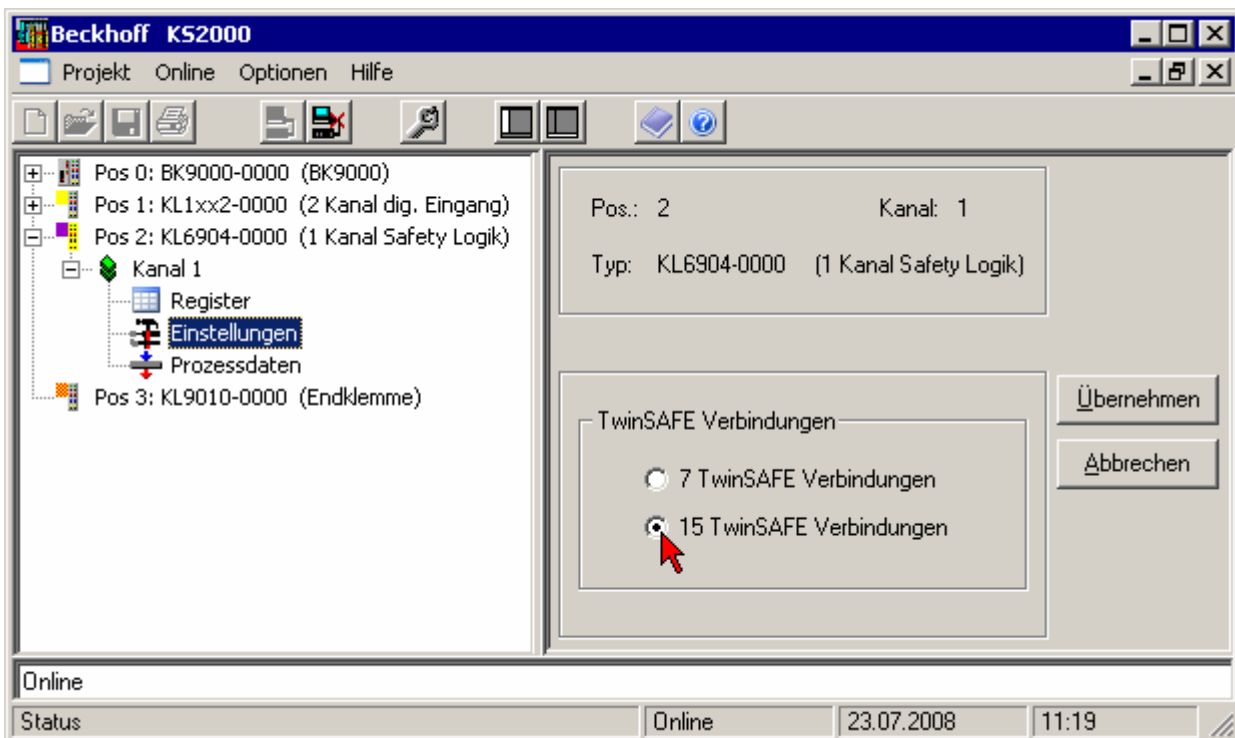

Fig. 12: Configuration

After the changeover to the new process image the KL6904 must be de-energized and switched on again in order to activate the change.



### 5.3.5 Address settings on TwinSAFE terminals with 1023 possible addresses

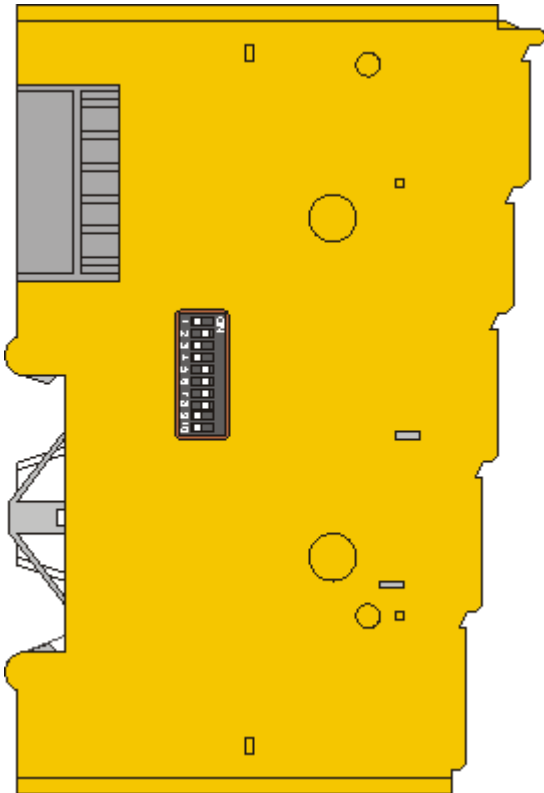

Fig. 13: Address settings on TwinSAFE terminals with 1023 possible addresses

The TwinSAFE address of the terminal is set via the 10-way DIP switch on the left-hand side of the TwinSAFE terminal. TwinSAFE addresses between 1 and 1023 are available.

DIP switch										Address
1	2	3	4	5	6	7	8	9	10	
ON	OFF	OFF	OFF	OFF	OFF	OFF	OFF	OFF	OFF	1
OFF	ON	OFF	OFF	OFF	OFF	OFF	OFF	OFF	OFF	2
ON	ON	OFF	OFF	OFF	OFF	OFF	OFF	OFF	OFF	3
OFF	OFF	ON	OFF	OFF	OFF	OFF	OFF	OFF	OFF	4
ON	OFF	ON	OFF	OFF	OFF	OFF	OFF	OFF	OFF	5
OFF	ON	ON	OFF	OFF	OFF	OFF	OFF	OFF	OFF	6
ON	ON	ON	OFF	OFF	OFF	OFF	OFF	OFF	OFF	7
...	...	...	...	...	...	...	...	...	...	...
ON	ON	ON	ON	ON	ON	ON	ON	ON	ON	1023

**⚠ WARNING**

**TwinSAFE address**

Each TwinSAFE address may only be used once within a network / a configuration!  
The address 0 is not a valid TwinSAFE address!

### 5.3.6 Creating a TwinSAFE Group

A TwinSAFE Group is a group of TwinSAFE Terminals (inputs and outputs) that are logically linked via a KL6904. Any communication faults in the TwinSAFE connections of this group lead to the whole group being switched off. Other TwinSAFE Groups are not affected.

A TwinSAFE Group is added by right-clicking on the associated KL6904 in the tree structure and selecting *Append TwinSAFE Group* in the dialog box (see diagram).

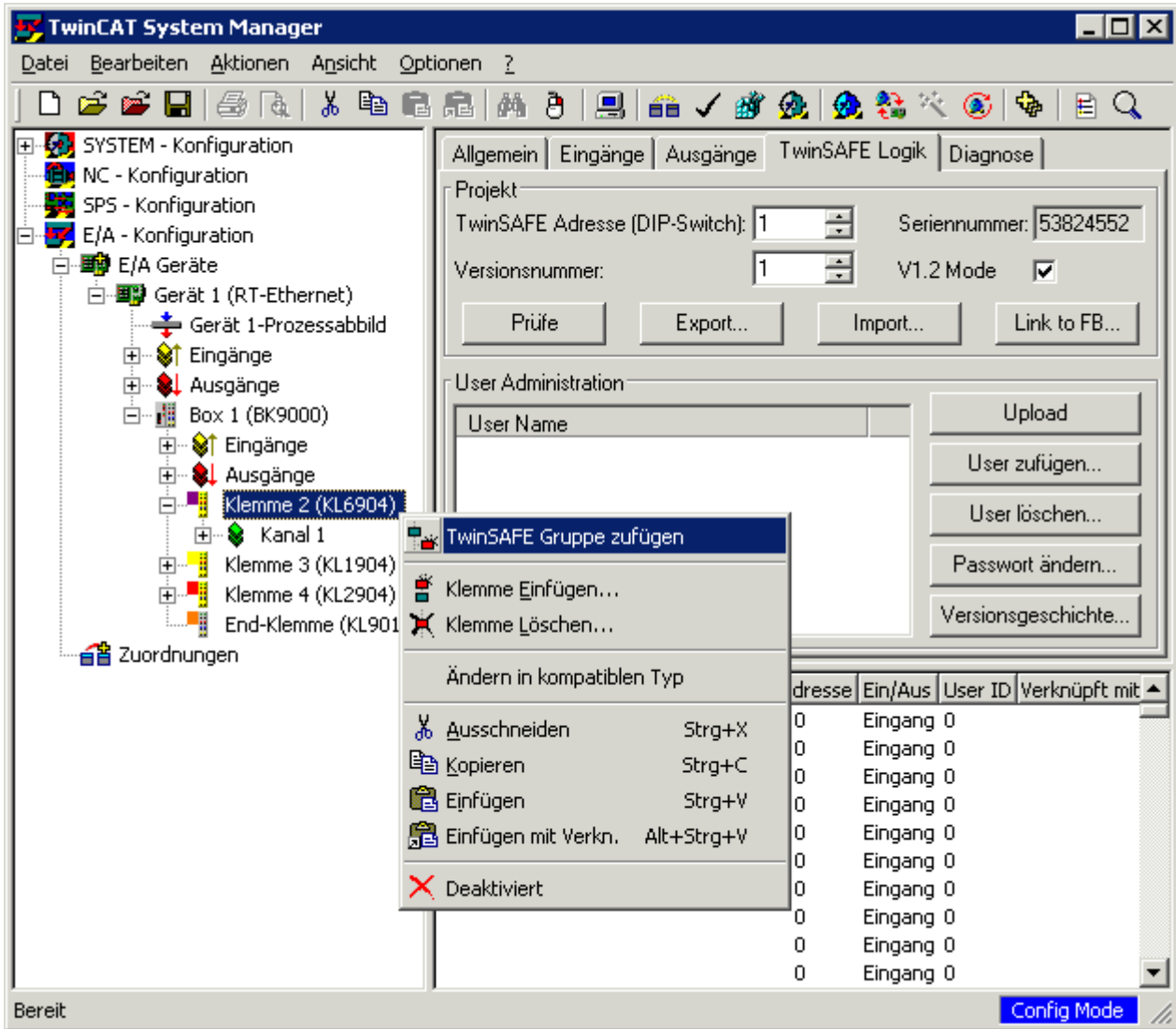

Fig. 14: Creating a TwinSAFE Group

### 5.3.6.1 TwinSAFE Group signals

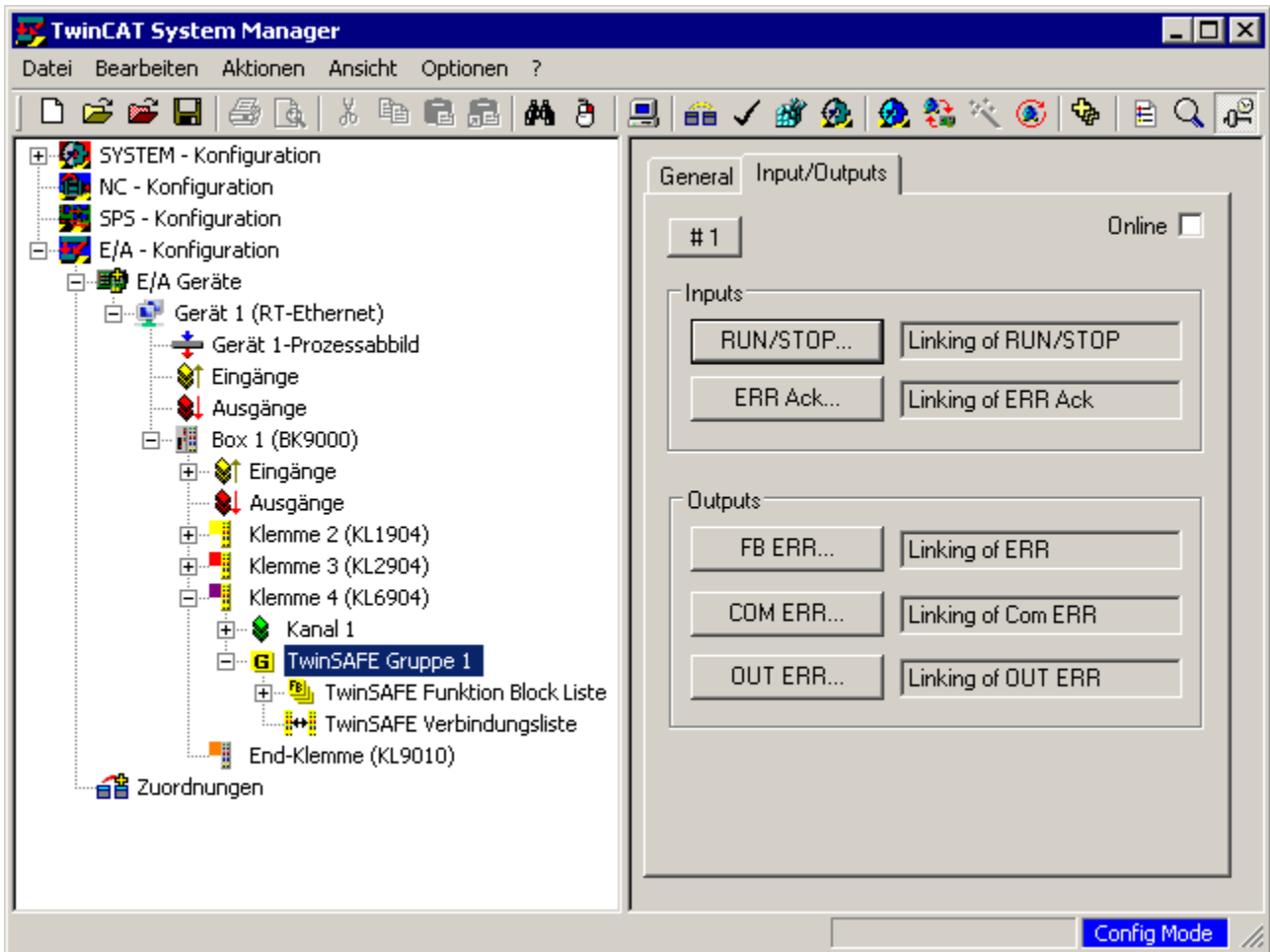

Fig. 15: TwinSAFE Group signals

#### TwinSAFE Group inputs

Name	Permitted type	Description
RUN	FB-Out	TRUE: The function blocks assigned to the TwinSAFE Group are executed. When the input is not linked it is in the TRUE state
	Standard-In	FALSE: All of the TwinSAFE Group assigned function blocks are at a STOP state and thus all associated outputs are in a safe state
ERR Ack	FB-Out Standard-In	All pending errors in the assigned function blocks and in the TwinSAFE connections are acknowledged by the FALSE->TRUE->FALSE signal sequence.

#### TwinSAFE Group outputs

Name	Permitted type	Description
FB ERR	TwinSAFE-Out	TRUE: At least one assigned function block has an error
	FB-In Standard-Out	FALSE: All assigned function blocks have no errors
COM ERR	TwinSAFE-Out	TRUE: At least one TwinSAFE connection of the TwinSAFE Group has an error
	FB-In Standard-Out	FALSE: All TwinSAFE connections of the TwinSAFE Group have no errors

Name	Permitted type	Description
OUT ERR	TwinSAFE-Out	TRUE: At least one locally assigned output of the TwinSAFE Group has an error
	FB-In Standard-Out	FALSE: All of the locally assigned outputs of the TwinSAFE Group have no errors

### 5.3.7 TwinSAFE Group signals

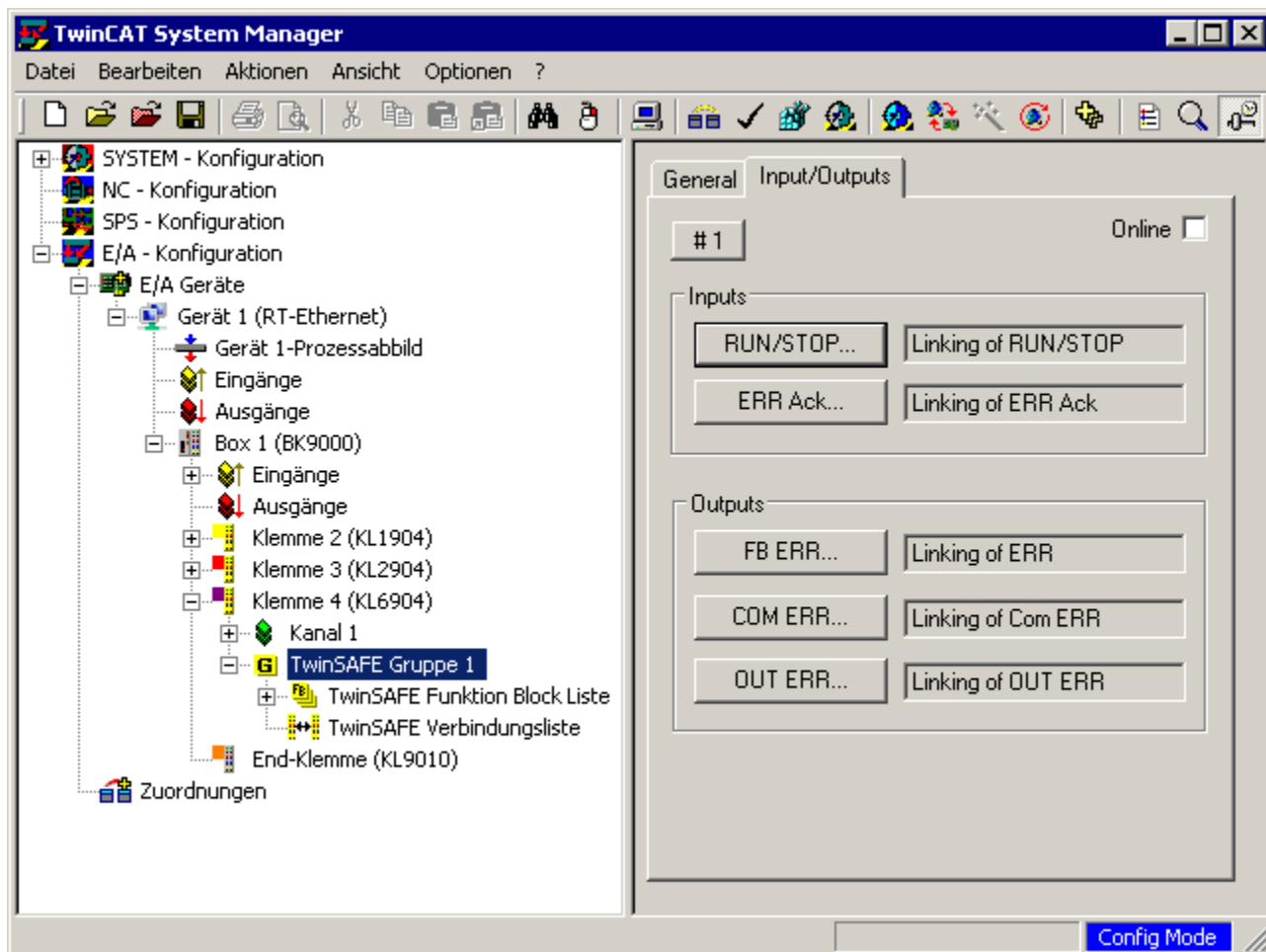

Fig. 16: TwinSAFE Group signals

#### TwinSAFE Group inputs

Name	Permitted type	Description
RUN	FB-Out	TRUE: The function blocks assigned to the TwinSAFE Group are executed. When the input is not linked it is in the TRUE state
	Standard-In	FALSE: All of the TwinSAFE Group assigned function blocks are at a STOP state and thus all associated outputs are in a safe state
ERR Ack	FB-Out Standard-In	All pending errors in the assigned function blocks and in the TwinSAFE connections are acknowledged by the FALSE->TRUE->FALSE signal sequence.

TwinSAFE Group outputs

Name	Permitted type	Description
FB ERR	TwinSAFE-Out	TRUE: At least one assigned function block has an error
	FB-In Standard-Out	FALSE: All assigned function blocks have no errors
COM ERR	TwinSAFE-Out	TRUE: At least one TwinSAFE connection of the TwinSAFE Group has an error
	FB-In Standard-Out	FALSE: All TwinSAFE connections of the TwinSAFE Group have no errors
OUT ERR	TwinSAFE-Out	TRUE: At least one locally assigned output of the TwinSAFE Group has an error
	FB-In Standard-Out	FALSE: All of the locally assigned outputs of the TwinSAFE Group have no errors

### 5.3.8 Append a function block

The KL6904 TwinSAFE Logic Terminal features function blocks like Emergency Stop, Machine Monitoring, AND, OR, Decoupler, Operation Mode, etc.

A function block is added by right-clicking on the corresponding TwinSAFE Function Block List in the tree structure and selecting Append Function Block with the left mouse button in the dialog box that opens (see figure).

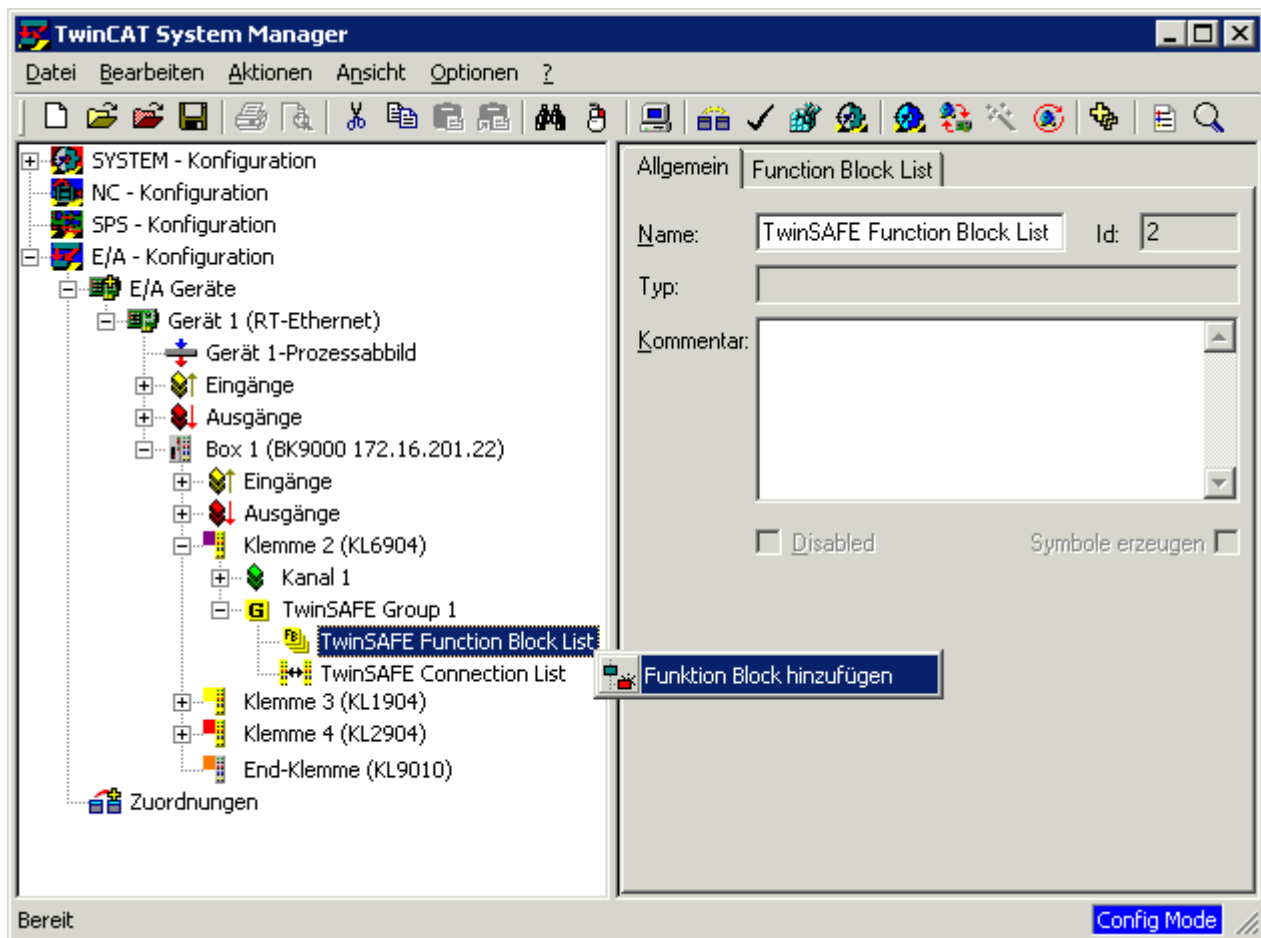

Fig. 17: Add FB

The required function block can then be selected from the following window.

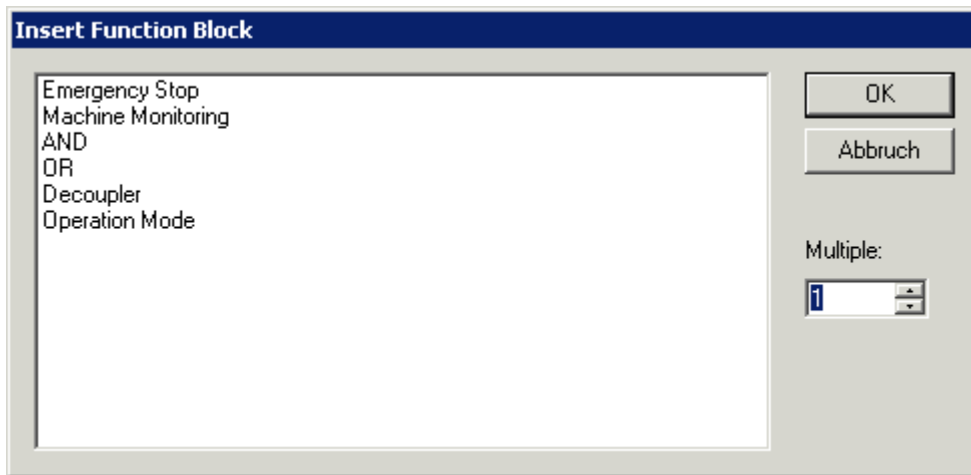

Fig. 18: Select FB

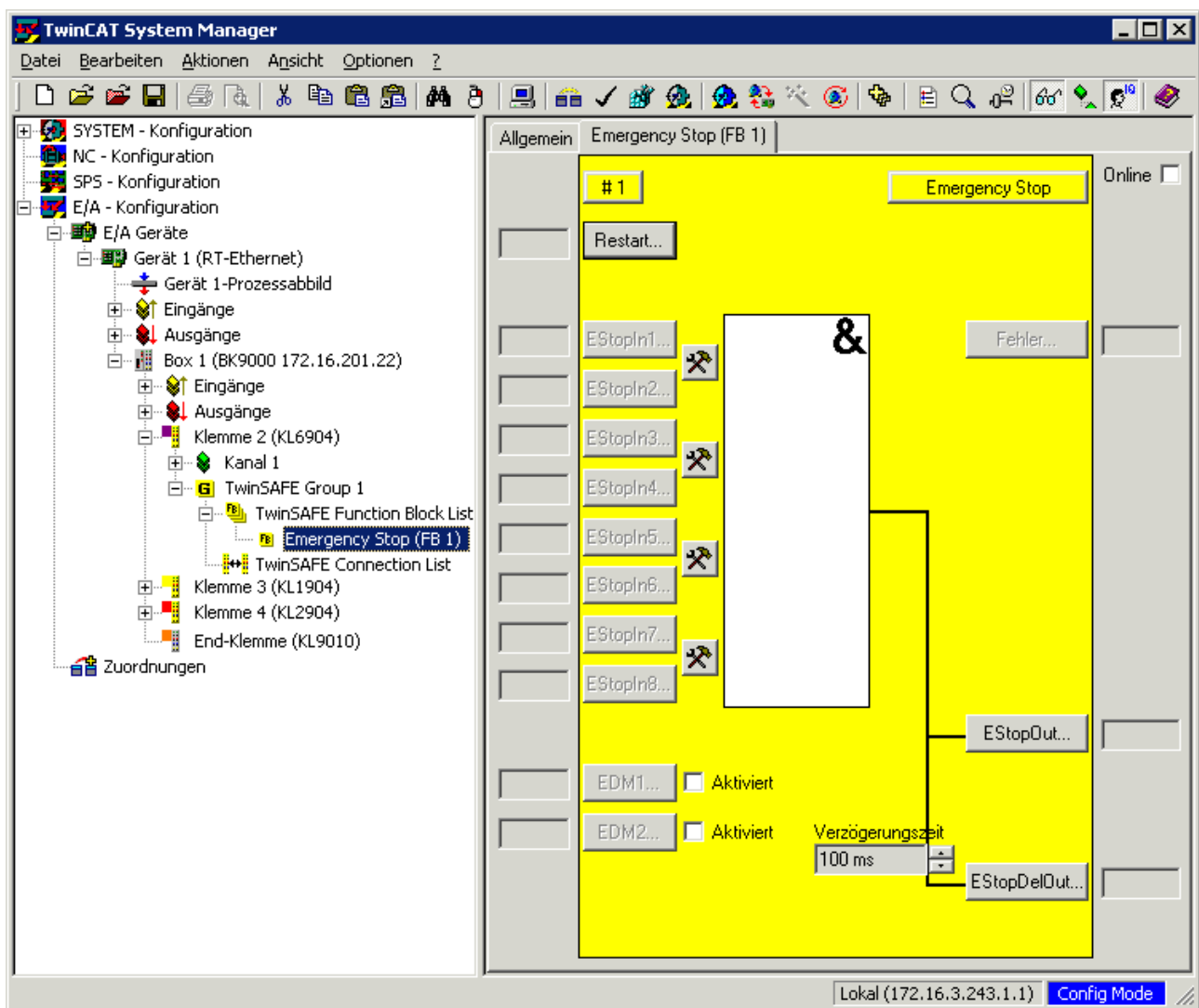

Fig. 19: Added FB

5.3.8.1 Activating and configuring the function block inputs

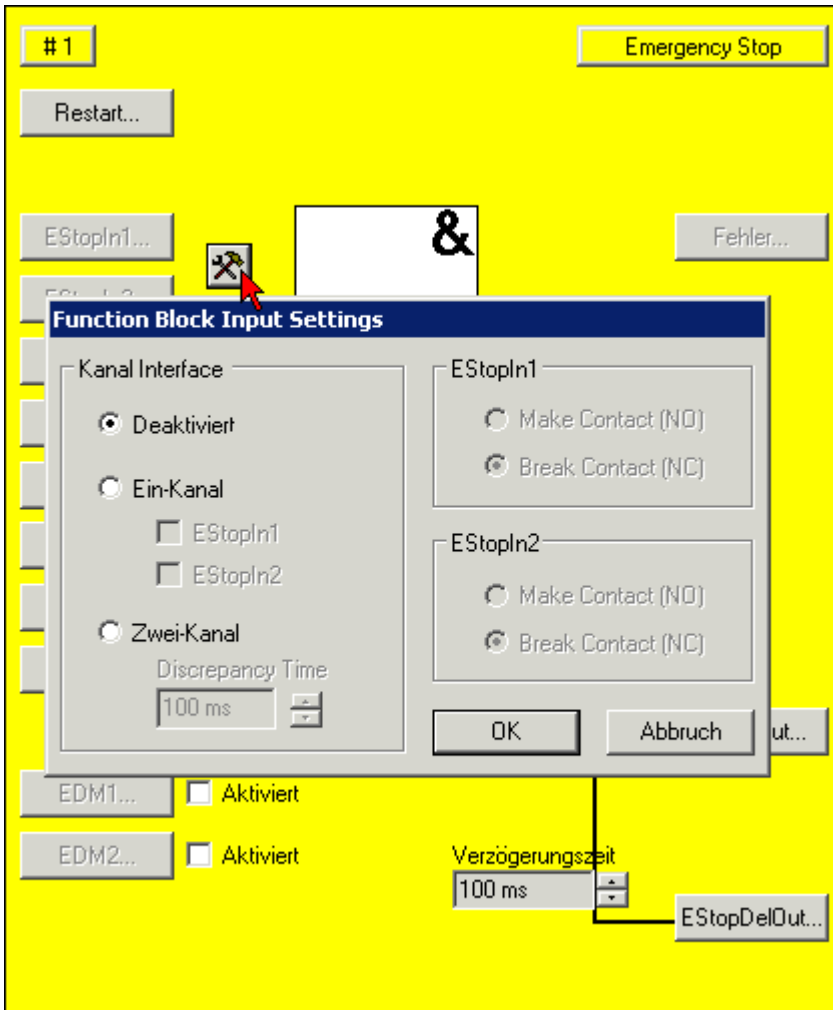

Fig. 20: Activate function block

The following parameters can be set:

- Deactivated: The input is not used
- Single-Channel: The inputs are linked independent of each other
- Two-Channel: The inputs are monitored for equality or inequality, depending on the contact type setting. A Discrepancy Time can be set for monitoring the two inputs for simultaneous switching.
- Make Contact: Contact type setting
- Break Contact: Contact type setting

The inputs are now activated.

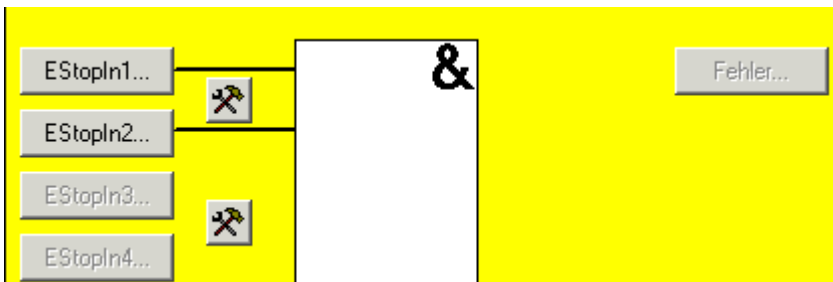

Fig. 21: Active inputs

The inputs can now be linked.

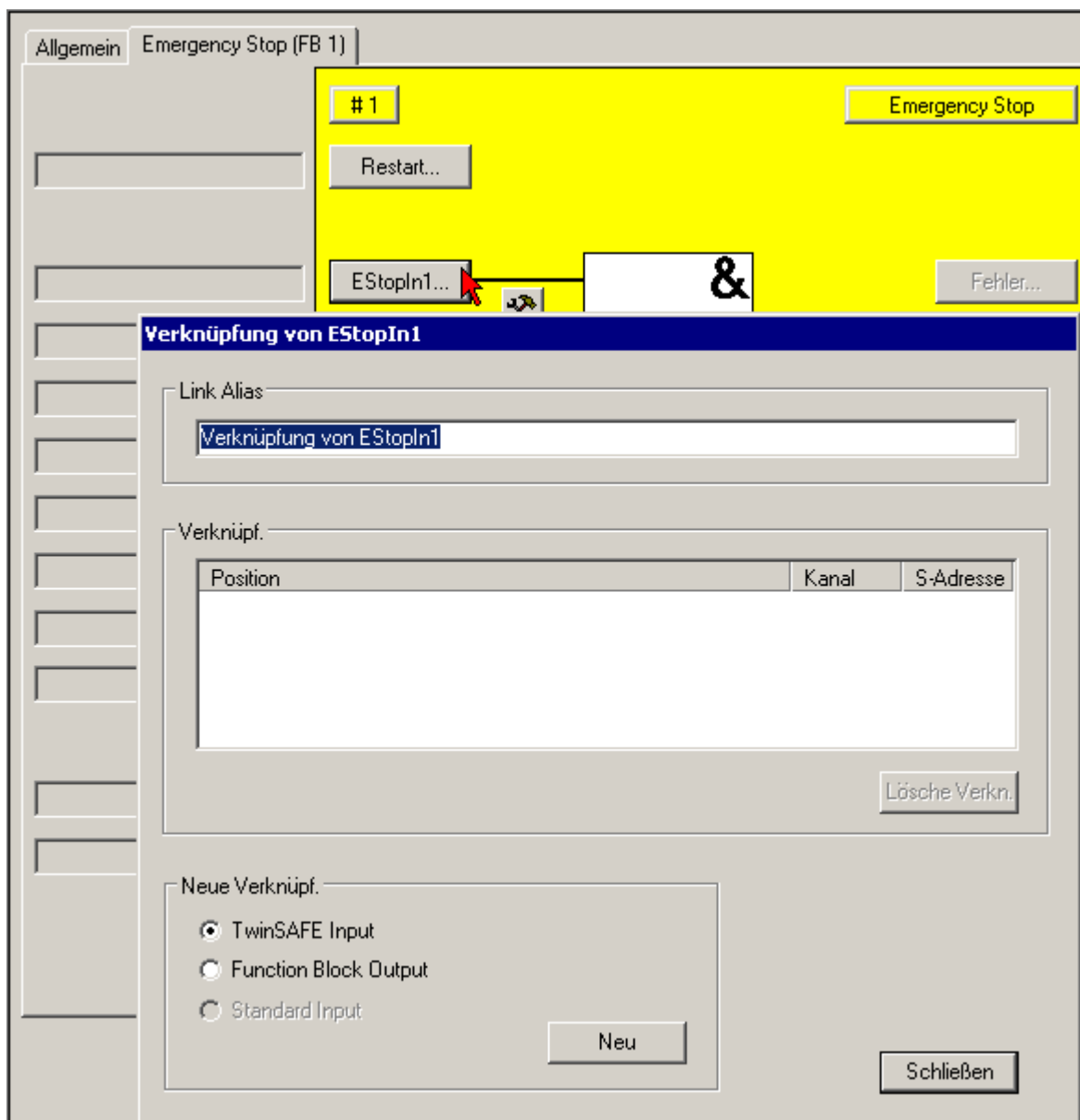

Fig. 22: Link inputs

Select the variable type:

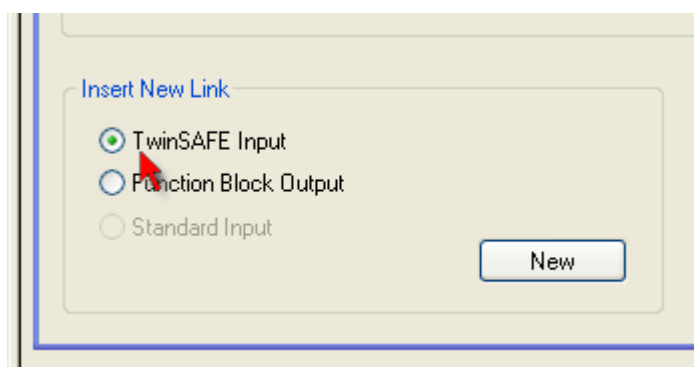

Fig. 23: Select the variable type

Clicking on the *New* button opens the following dialog:



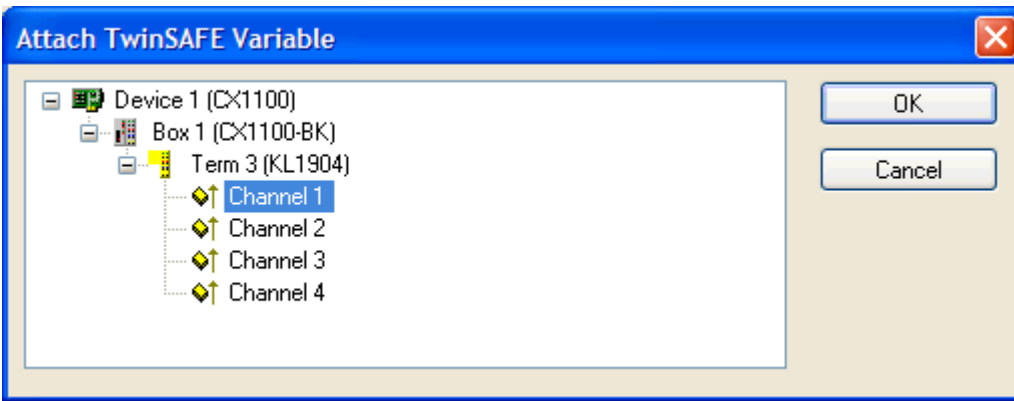

Fig. 24: Select channel

All available channels are displayed as selected.

The required channel is selected and highlighted in blue with the mouse. The selection is confirmed via the OK button.

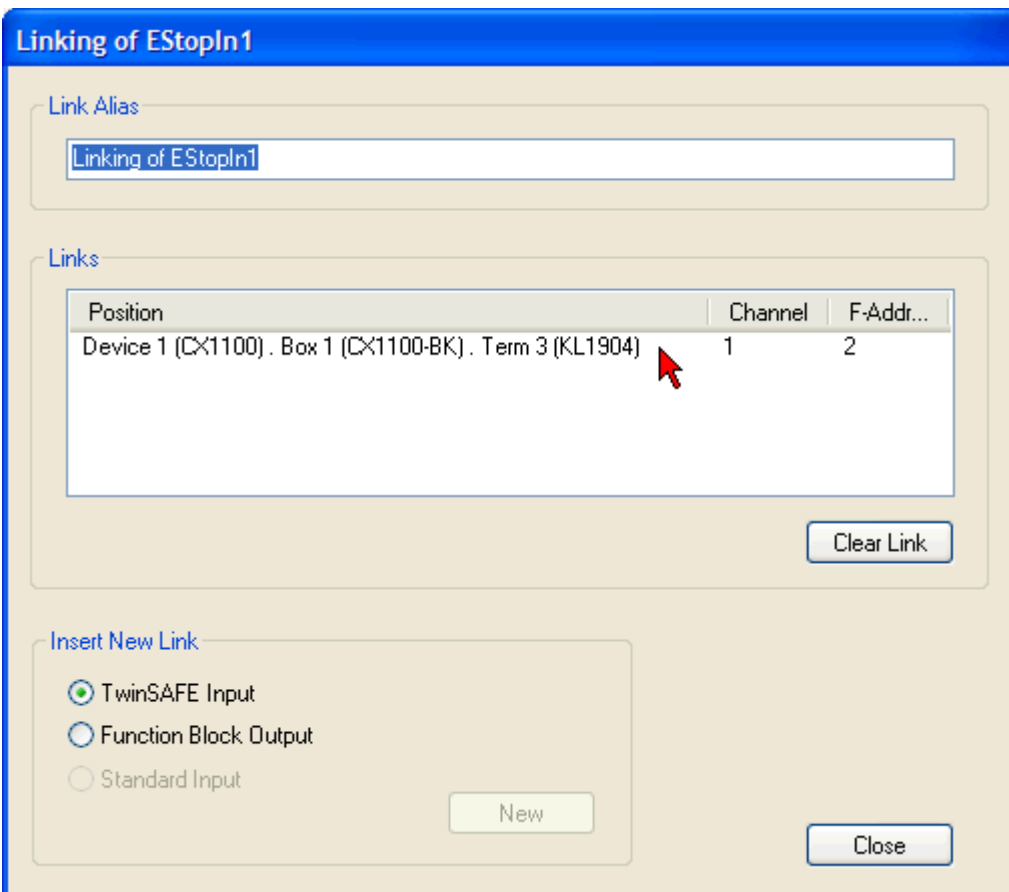

Fig. 25: Link channel

The name of the variables should now be entered in the field *Link Alias*.

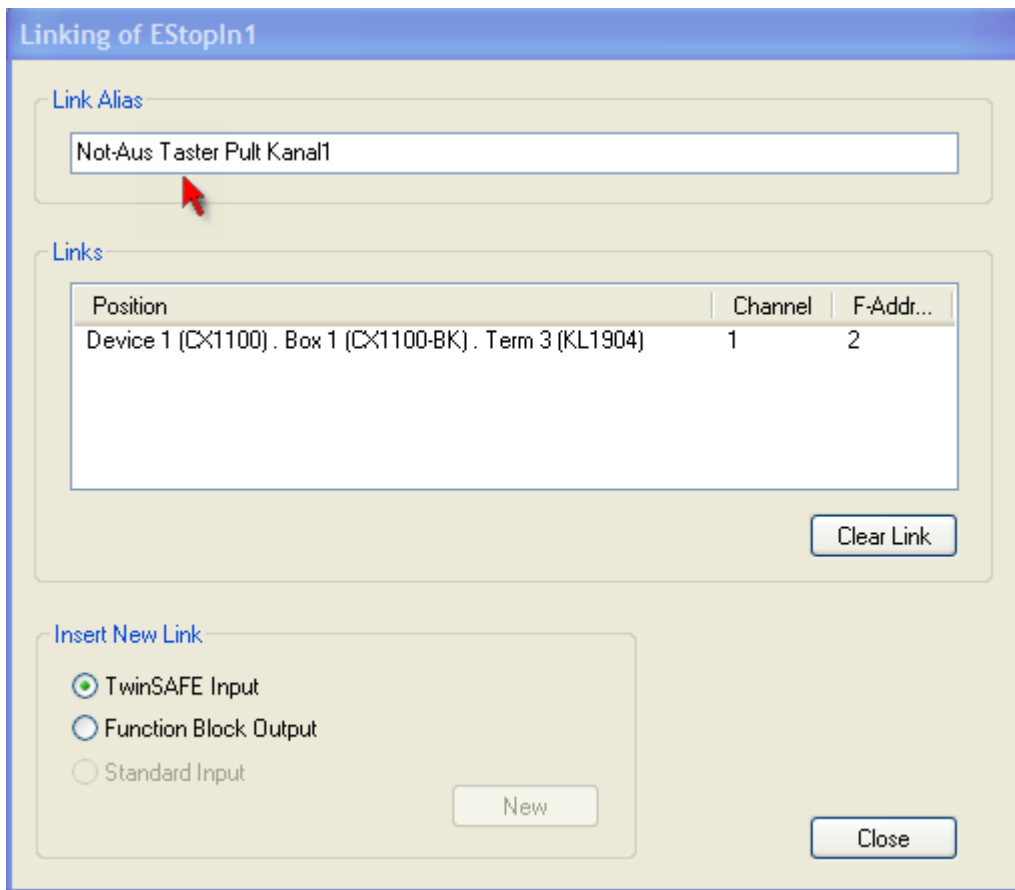

Fig. 26: Enter name

Repeat the process for the other inputs. Inputs that are already in use are identified with an arrow.

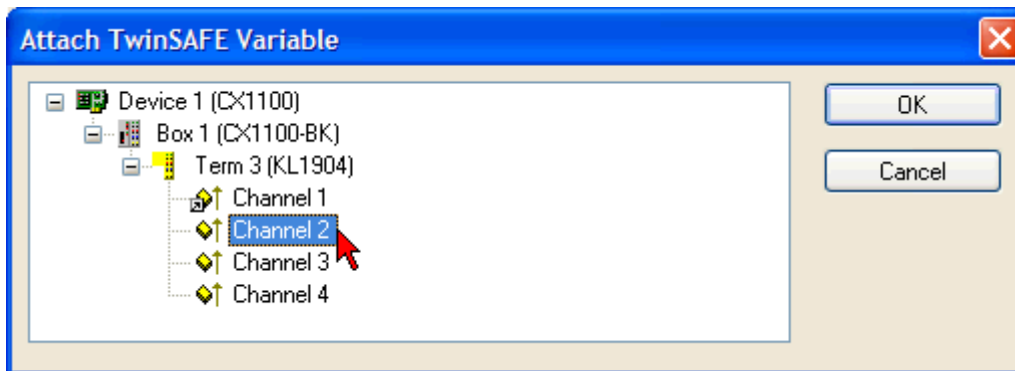

Fig. 27: Link further inputs

### 5.3.9 KL6904 user and version administration

The KL6904 has a user administration function. The administrator can create further users and issue associated passwords.

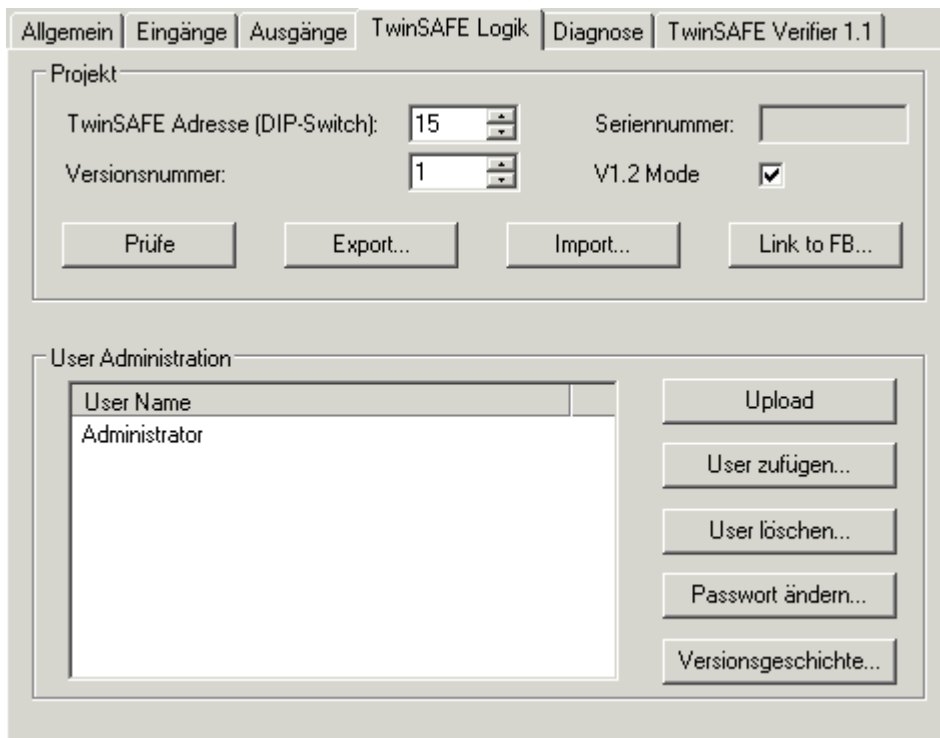

Fig. 28: Version History

Clicking the Version History button displays the version history stored on the KL6904, which cannot be deleted, and shows who activated which version of a project on the KL6904 and when.

### 5.3.10 Loading the project into the KL6904

The project is loaded into the KL6904 via the fieldbus.

#### ⚠ CAUTION

##### Use only qualified tools

Only use a qualified tool for loading, verifying and enabling the project on the KL6904!

Click the Download button on the TwinSAFE Verifier tab for loading the project.

The user must enter

- his user name (default: Administrator),
- the terminal serial number (printed on the outside, e.g. 197535), and
- his password (default: TwinSAFE).

#### NOTICE

##### Case-sensitive

Pay attention to upper/lower case characters for the user name and password. User name and password are case-sensitive.

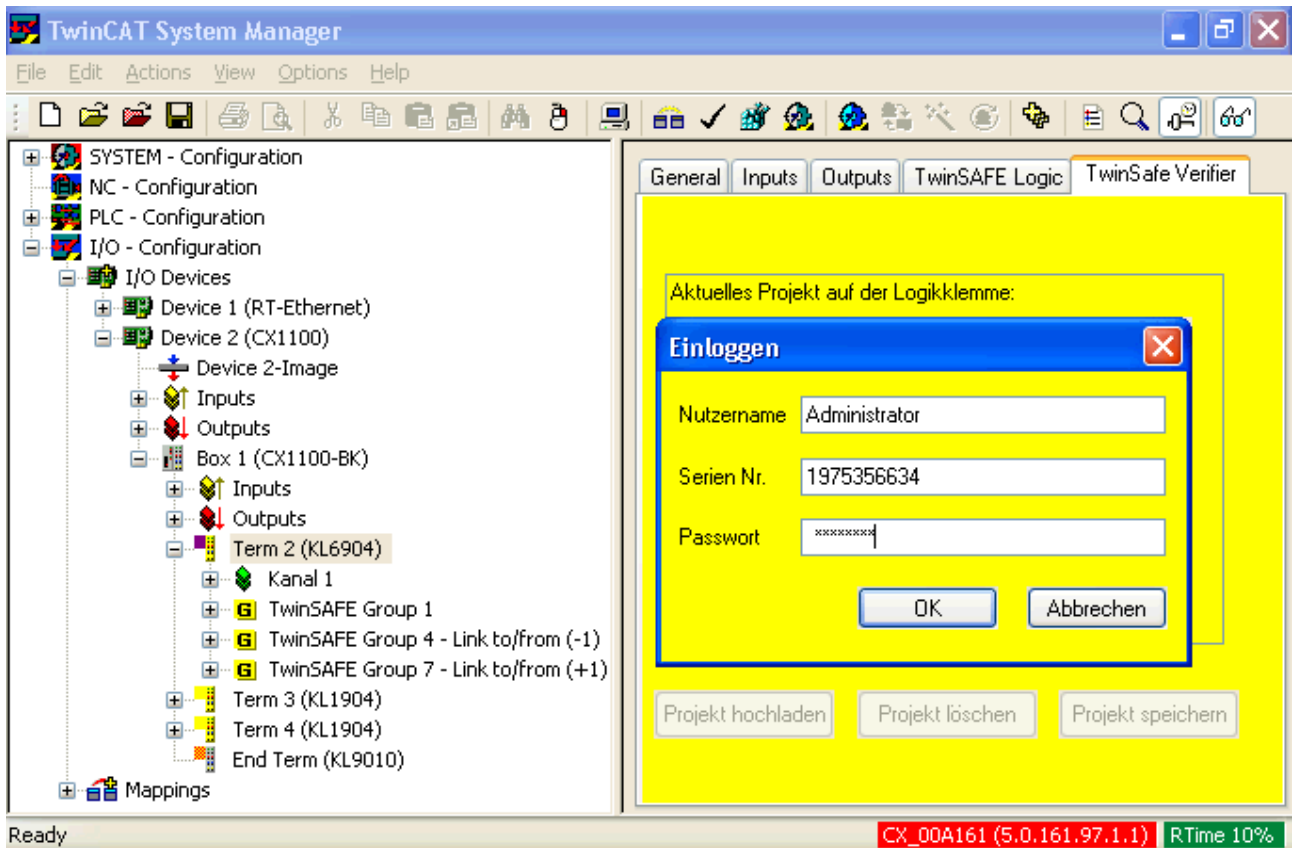

Fig. 29: Load project

The project is then displayed in text mode, and the user has to confirm consistency between the information displayed and the currently projected application by re-entering the password.

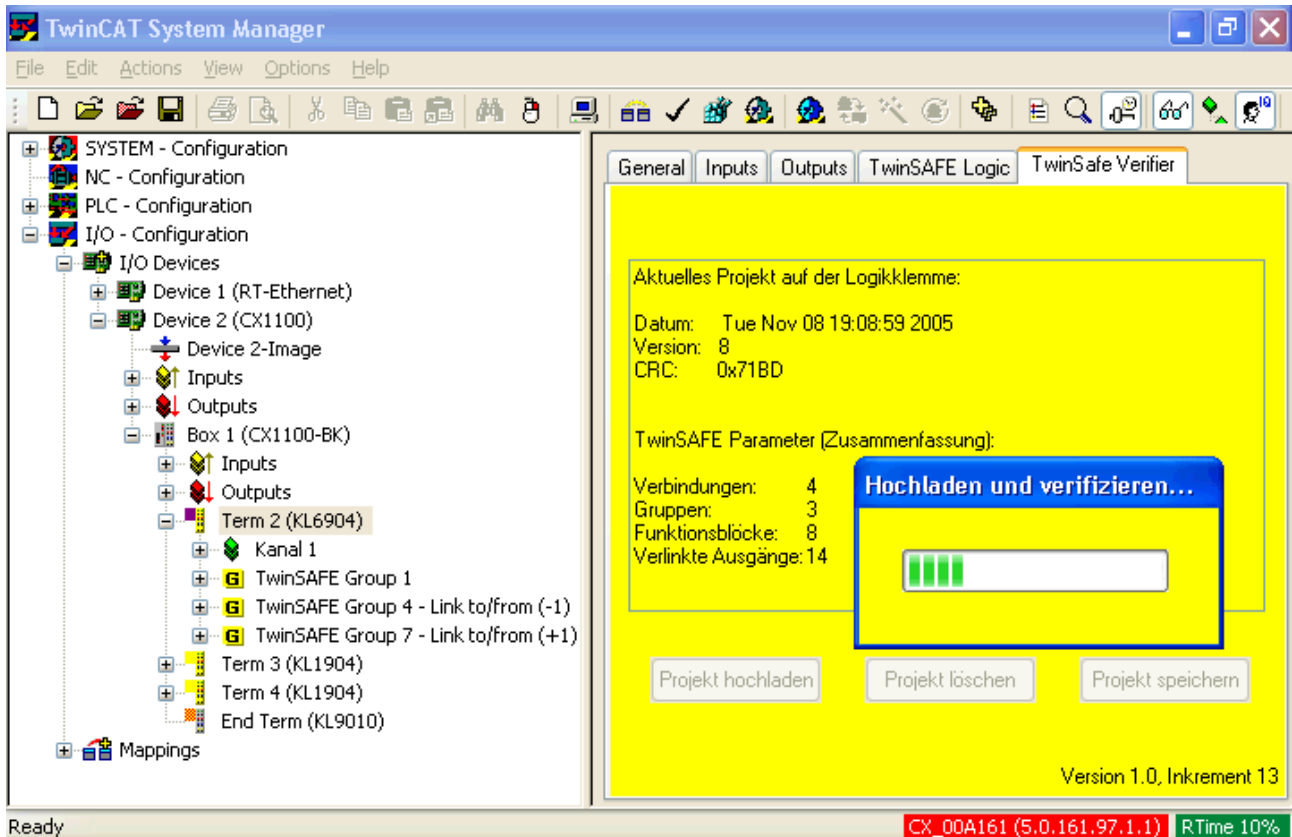

Fig. 30: Verify project

The project is then started on the KL6904.

### 5.3.10.1 KL6904 project design limits

<b>TwinSAFE connections</b>	max. 7 or 15 (see Inserting a KL6904)
<b>TwinSAFE function blocks</b>	maximum 48
<b>TwinSAFE Groups</b>	maximum 8
<b>Standard PLC inputs</b>	max. 24 bit
<b>Standard PLC outputs</b>	max. 24 bit



#### TwinSAFE connection

Only one TwinSAFE connection between two TwinSAFE Terminals is possible.

### 5.3.11 Communication between TwinCAT controllers

The MASTER\_MESSAGE and SLAVE\_MESSAGE data types are used for communication between two or more TwinCAT controllers via network variables.

Corresponding variables must be created on the communicating controllers under Publisher and Subscriber.

During TwinSAFE communication one side acts as the master, the other one as the slave.

This results in the following data types:

TwinSAFE Master Publisher	MASTER_MESSAGE
TwinSAFE Master Subscriber	SLAVE_MESSAGE
TwinSAFE Slave Publisher	SLAVE_MESSAGE
TwinSAFE Slave Subscriber	MASTER_MESSAGE

The link with the TwinSAFE logic terminal KL6904 is established with the following dialog:

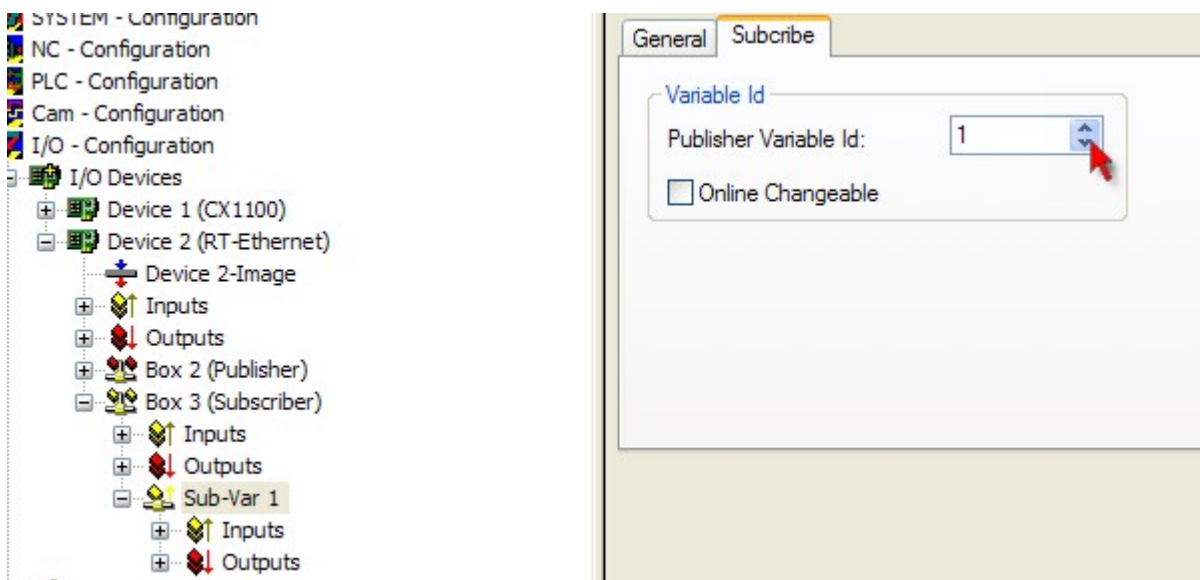

Fig. 31: Linking with the TwinSAFE Logic Terminal

The connection created must now be made known to the TwinSAFE Logic terminal. This is done by marking the TwinSAFE Connection List and pressing the right mouse button.

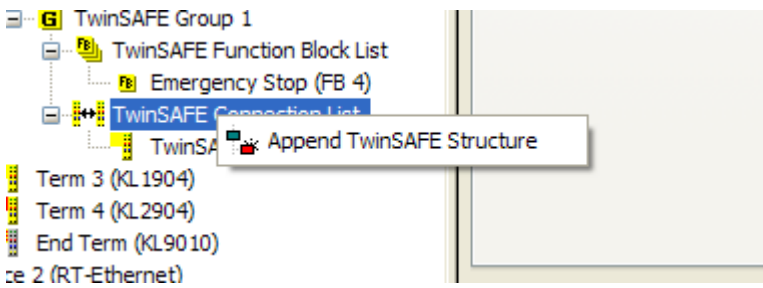

Fig. 32: Create connection

The variables of type MASTER\_MESSAGE and SLAVE\_MESSAGE are now displayed, and both (In/Out) have to be selected.

The selection is confirmed via the OK button.

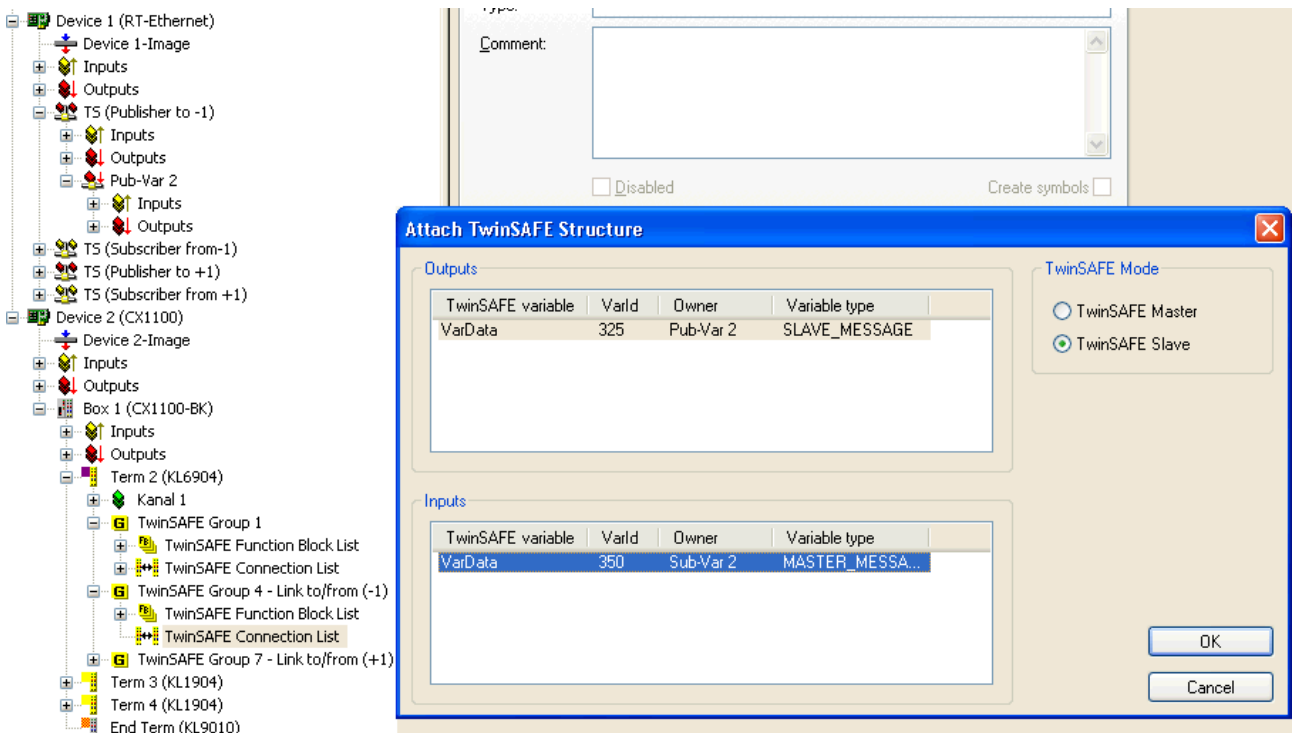

Fig. 33: Confirm variable selection

A new connection will appear in the list of TwinSAFE connections.

The connection has to be set on the associated tab. One side must be a TwinSAFE master, the other one a TwinSAFE slave.

The F address of the partner device must also be set. Please not the DIP switch on the left-hand side of the KL6904.

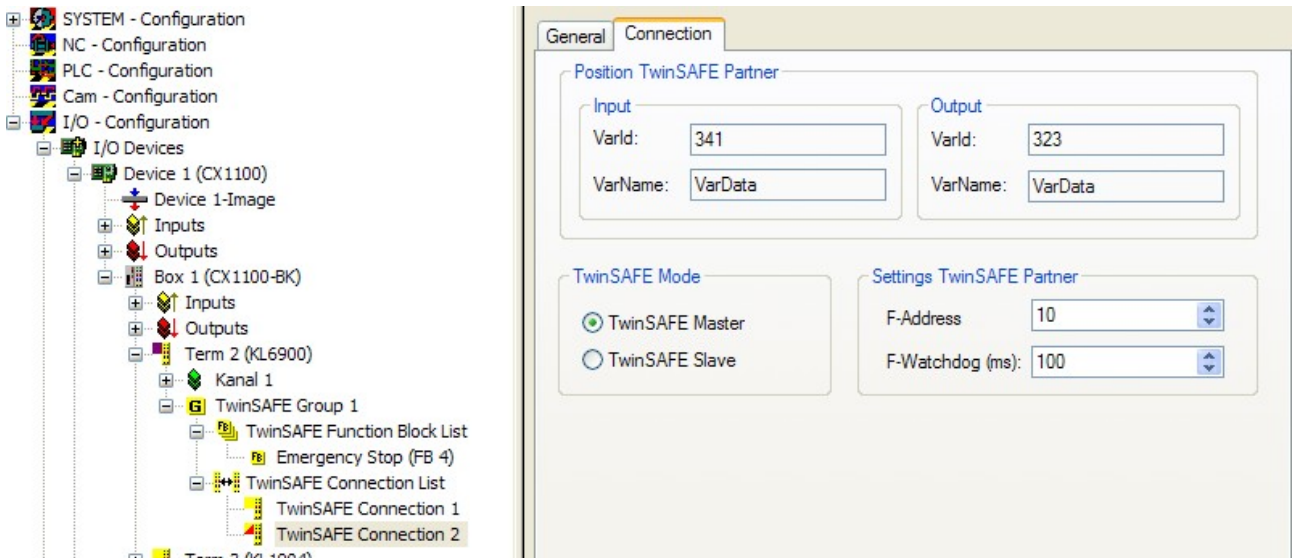

Fig. 34: Setting the connection

If several connections are to be established, a unique ID must be set for each Publisher variable.

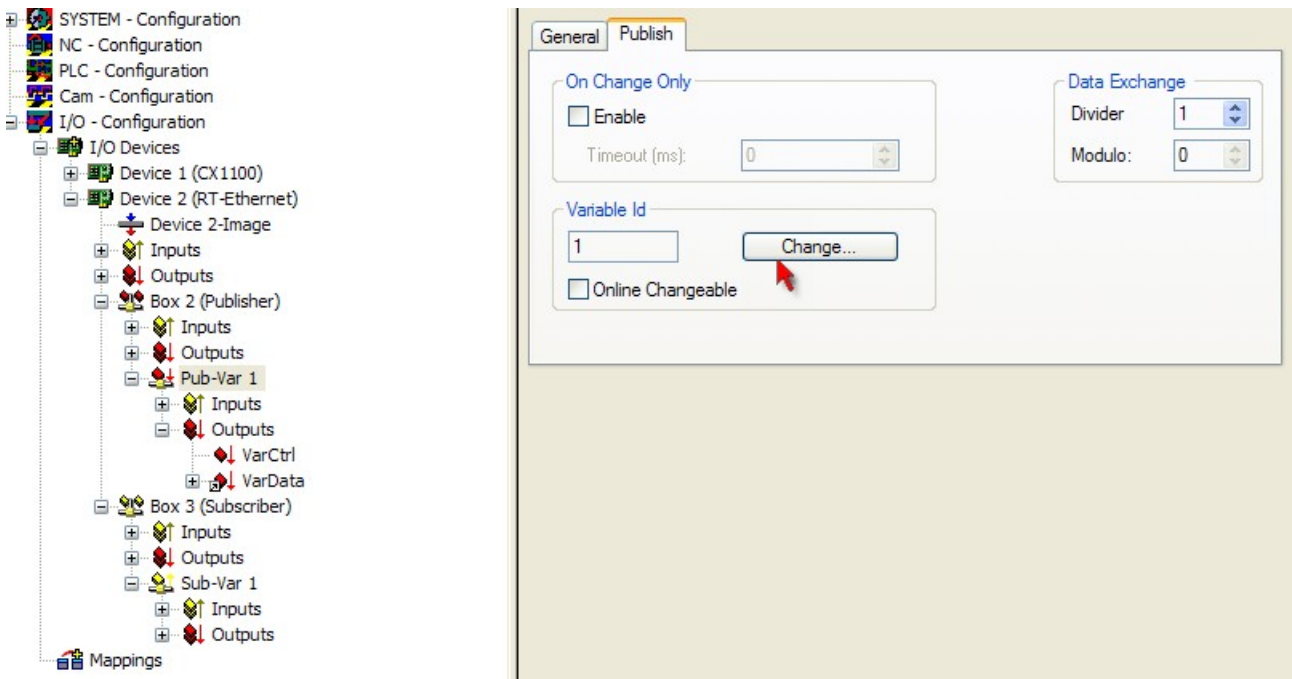

Fig. 35: Setting ID

This ID must also be set on the partner device, i.e. the Subscriber.

The network variables can now be used in the project. The inputs are shown under TwinSAFE Input, the outputs under TwinSAFE Output.

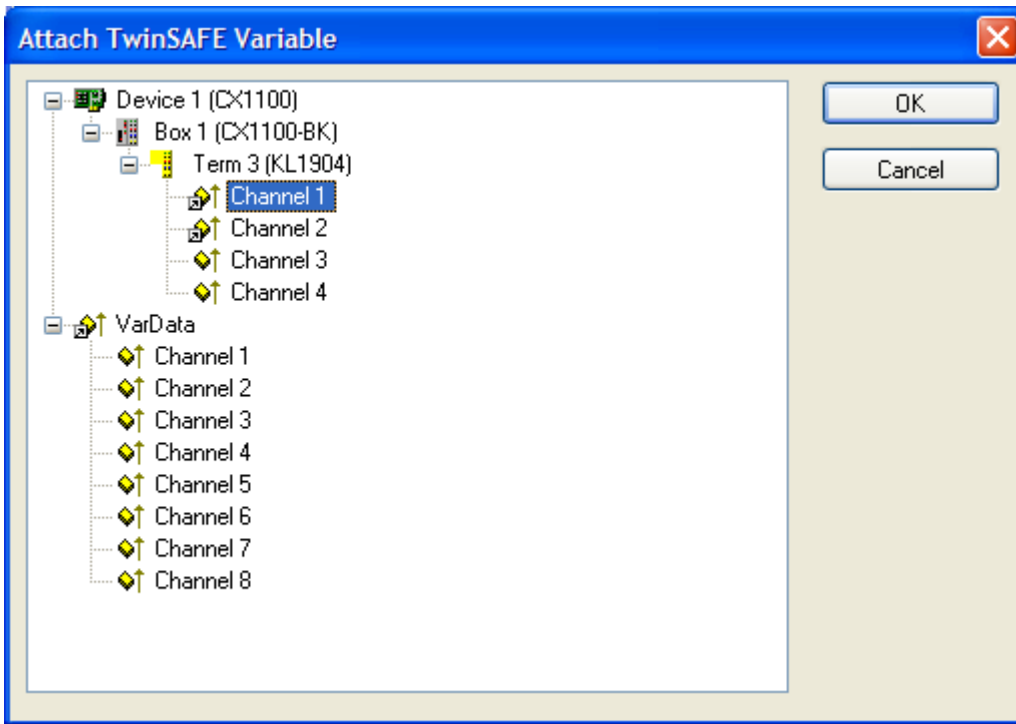

Fig. 36: Link input variable

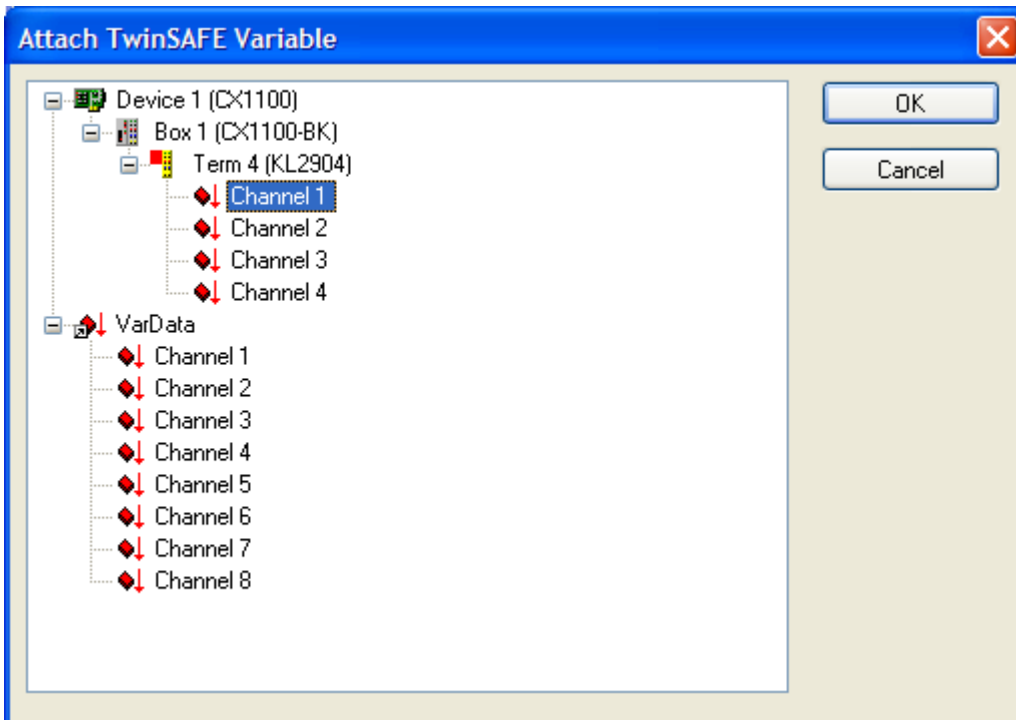

Fig. 37: Link output variable



## 6 Diagnosis

### 6.1 Diagnostic LEDs

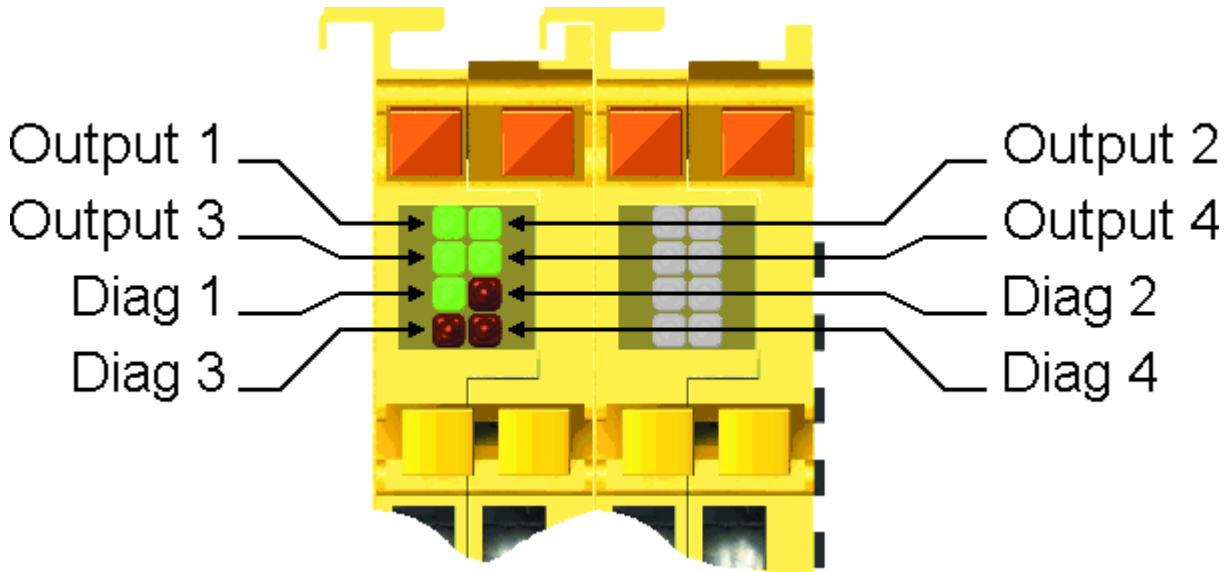

Fig. 38: Diagnostic LEDs

#### 6.1.1 Diag1 (green)

The Diag 1 LED indicates the state of the TwinSAFE interface.

Flashing Code	Meaning
LED illuminated continuously	normal operation: TwinSAFE communication OK
rapid flickering, alternating with 1 flash pulse	Communication error: At least one connection is not in Run state.
rapid flickering, alternating with 2 flash pulses	Error in the function block
rapid flickering, alternating with 3 flash pulses	Error in the function block and communication error: At least one connection is not in the Run state.

These errors can be reset through a falling edge at the ERR\_ACK input of the TwinSAFE Group.

#### 6.1.2 DIAG2 (red)

The Diag 2 LED indicates the state of the digital outputs.

Flashing Code	Meaning
rapid flickering, alternating with 1 flash pulse	Output 1: Open load or current below minimum value of 20 mA or current above maximum value of 500 mA
rapid flickering, alternating with 2 flash pulses	Output 2: Open load or current below minimum value of 20 mA or current above maximum value of 500 mA
rapid flickering, alternating with 3 flash pulses	Output 3: Open load or current below minimum value of 20 mA or current above maximum value of 500 mA
rapid flickering, alternating with 4 flash pulses	Output 4: Open load or current below minimum value of 20 mA or current above maximum value of 500 mA
rapid flickering, alternating with 5 flash pulses	Field voltage too low
rapid flickering, alternating with 6 flash pulses	Field voltage too high
rapid flickering, alternating with 7 flash pulses	Terminal temperature too low
rapid flickering, alternating with 8 flash pulses	Terminal temperature too high
rapid flickering, alternating with 9 flash pulses	Temperature difference error

Flashing Code	Meaning
rapid flickering, alternating with 10 flash pulses	Error in output circuit through Open Load, external supply or cross-circuit

These errors can be reset through a falling edge at the ERR\_ACK input of the TwinSAFE Group.

### 6.1.3 Diag3 (red) and Diag4 (red)

The Diag 3 and Diag 4 LEDs indicate internal terminal errors.

<b>NOTICE</b>	
<b>Returning the terminal</b>	
These errors lead to shutdown of the terminal. The terminal must be checked by Beckhoff Automation GmbH & Co. KG.	

Diag3	Diag4	Source of error
Lit	Flashes	µC1
Lit	Off	µC2

In the event of a fault the Diag 4 LED indicates the type of error through flashing codes. The flashing codes are structured as follows:

Flashing sequence	Meaning
Rapid flickering	Start of flashing code
First slow sequence	Error code
Second slow sequence	Error argument

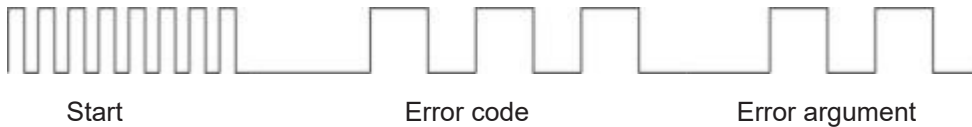

Count the number of flash pulses after the rapid flickering sequence

- during the first slow sequence in order to ascertain the error code
- during the second slow sequence in order to ascertain the error argument

The flashing code is repeated after the second slow sequence, followed by rapid flickering.

## 7 Service life

TwinSAFE components have a service life of 20 years, during which the safety parameters are guaranteed. For more information, see the chapter Safety parameters.

The service life starts from the date of manufacture according to the Date Code.

**⚠ WARNING**

**Replace TwinSAFE component after 20 years**

After a service life of 20 years, the safety parameters are no longer guaranteed.

*Use beyond the service life may result in loss of safety.*

Due to the high diagnostic coverage within the lifecycle no special proof tests are required.

The TwinSAFE components bear a Date Code, which is composed as follows:

Date Code: CW YY SW HW

Legend:	Example: Date Code 17 11 05 00
CW: calendar week of manufacture	Calendar week: 17
JJ: year of manufacture	Year: 2011
SW: software version	Software version: 05
HW: hardware version	Hardware version: 00

In addition the TwinSAFE components bear a unique serial number.

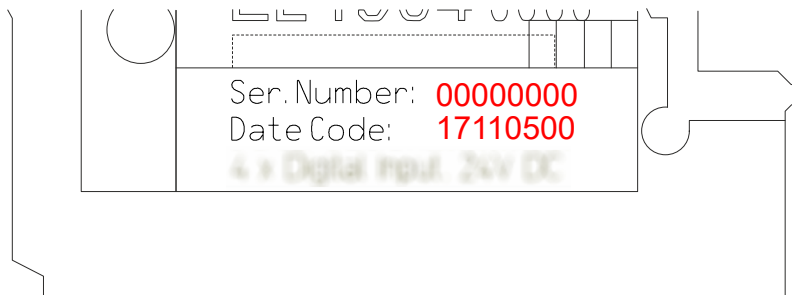

Fig. 39:

## 8 Maintenance and cleaning

---

### **i** Cleaning by the manufacturer only

Do not operate the TwinSAFE component if it is unacceptably dirty. Refer to the technical data for the protection class.

Send unacceptably dirty TwinSAFE component to the manufacturer for cleaning.

---

TwinSAFE components are basically maintenance-free.

## 9 Decommissioning

### 9.1 Disposal

#### NOTICE

##### Correct disposal

Observe the applicable national laws and guidelines for disposal.

Incorrect disposal may result in environmental damage.

Remove the TwinSAFE component for disposal.

Depending on your application and the products used, make sure that the respective components are disposed of properly:

##### Cast iron and metal

Hand over cast iron and metal parts to scrap metal recycling.

##### Cardboard, wood and polystyrene

Dispose of packaging materials made of cardboard, wood or Styrofoam in accordance with regulations.

##### Plastic and hard plastic

You can recycle parts made of plastic and hard plastic via the waste management center or reuse them in accordance with the component regulations and markings.

##### Oils and lubricants

Dispose of oils and lubricants in separate containers. Hand over containers to the waste oil collection point.

##### Batteries and accumulators

Batteries and accumulators may also be marked with the crossed-out wheeled garbage can symbol. You must separate these components from waste. You are legally obliged to return used batteries and accumulators within the EU. Outside the validity of the EU Directive 2006/66/EC, observe the respective regulations.

#### 9.1.1 Returning to the vendor

In accordance with the WEEE-2012/19/EU directives, you can return used devices and accessories for professional disposal. The transport costs are borne by the sender.

Send the used devices with the note "For disposal" to:

Beckhoff Automation GmbH & Co. KG  
Gebäude „Service“  
Stahlstraße 31  
D-33415 Verl

In addition, you have the option to contact a local certified specialist company for the disposal of used electrical and electronic appliances. Dispose of the old components in accordance with the regulations applicable in your country.

## 10 Appendix

### 10.1 Volatility

If there are requirements concerning the volatility of products in your application, for example of the U.S. Department of Defense or similar authorities or security organizations, the following process applies:

The product has both volatile and non-volatile components. Volatile components lose their data immediately after removing power. Non-volatile components keep the data even after loss of power.

If there is customer specific data saved on the product, it cannot be ensured that this data might not be restored through for example forensic measures, even after the data is deleted through the provided tool chain. If this data is confidential, the scrapping of the product after usage is recommended to protect this data.

## 10.2 Focus of certificates

The most decisive document for certified components of the TwinSAFE department is the EC type examination certificate. The document contains both the test coverage and the regarded component and component family.

The current certificates of all TwinSAFE components with the underlying standards and directives can be found at <https://www.beckhoff.com/en-en/support/download-finder/certificates-approvals/>.

If the document refers only to the first four figures of a product (ELxxxx), the certificate is valid for all available variants of the component (ELxxxx-abcd). This is applicable for all components like EtherCAT Terminals, EtherCAT Boxes, EtherCAT plug-in modules and Bus Terminals.

CERTIFICADO ◆ CERTIFICADO ◆ CERTIFICADO ◆ CERTIFICADO ◆ CERTIFICADO ◆



SUD  
Product Service

# EC-Type Examination Certificate

No. M6A 062386 0055 Rev. 01

<b>Holder of Certificate:</b>	<b>Beckhoff Automation GmbH &amp; Co. KG</b> Hülshorstweg 20 33415 Verl GERMANY
<b>Product:</b>	<b>Safety components</b>
<b>Model(s):</b>	<b>EL1918</b>
<b>Parameters:</b>	Supply voltage: 24VDC (-15%/+20%) Ambient temperature: -25°C...+55°C Protection class: IP20

This EC Type Examination Certificate is issued according to Article 12(3) b or 12(4) a of Council Directive 2006/42/EC relating to machinery. It confirms that the listed Annex-IV equipment complies with the principal protection requirements of the directive. It refers only to the sample submitted to TÜV SÜD Product Service GmbH for testing and certification. For details see: [www.tuvsud.com/ps-cert](http://www.tuvsud.com/ps-cert)

<b>Test report no.:</b>	BV99670C
-------------------------	----------



If you regard the example EL1918 in the picture, the certificate is valid for both the EL1918 and the available variant EL1918-2200.





More Information:

Beckhoff Automation GmbH & Co. KG  
Hülshorstweg 20  
33415 Verl  
Germany  
Phone: +49 5246 9630  
[info@beckhoff.com](mailto:info@beckhoff.com)  
[www.beckhoff.com](http://www.beckhoff.com)

