

Manual | EN

TS511x

TwinCAT 2 | Kinematic Transformation



Supplement | Motion



Inhaltsverzeichnis

1 Foreword	5
1.1 Notes on the documentation.....	5
1.2 Safety instructions	6
2 Installation	7
3 Configuration	8
4 Supported Transformations	11
4.1 Static Transformation	12
4.2 H-Bot.....	13
4.3 2-D-Kinematics Type 1	14
4.4 2-D-Kinematics Type 2	15
4.5 2-D-Kinematics Type 3	16
4.6 Delta Type 1	17
4.7 SCARA	19
4.8 5D-Kinematics Type 2 (XYZab).....	19
4.9 Drive Torque	21
4.10 Tool Offset	21
4.11 Tool Linear.....	22
5 Plc Library	23
5.1 Function Blocks	23
5.1.1 FB_ConfigKinGroup.....	23
5.1.2 FB_ResetKinGroup.....	25
5.1.3 FB_CheckActualKinStatus.....	27
5.1.4 FB_CalcTrafo.....	29
5.1.5 FB_UnlockTrafoParam	31
5.1.6 FB_LockTrafoParam.....	33
5.2 Functions	34
5.2.1 F_GetKinChnOperationState	34
5.2.2 F_GetAcsMcsAxisIds.....	35
5.3 Datatypes	36
5.3.1 ST_KinAxes	36
5.3.2 E_KINSTATUS	37
6 Error Codes	38
6.1 ADS Return Codes	38
6.2 Overview of NC Errors.....	41
6.2.1 General NC Errors	41
6.2.2 Channel Errors.....	43
6.2.3 Group Errors	46
6.2.4 Axis Errors	65
6.2.5 Encoder Errors.....	72
6.2.6 Controller Errors	77
6.2.7 Drive Errors.....	81
6.2.8 Table Errors	87
6.2.9 NC-PLC Errors.....	89

6.2.10	Kinematic Transformation.....	94
6.2.11	Bode Return Codes	95
6.2.12	Further Error Codes.....	97

1 Foreword

1.1 Notes on the documentation

This description is only intended for the use of trained specialists in control and automation engineering who are familiar with applicable national standards.

It is essential that the documentation and the following notes and explanations are followed when installing and commissioning the components.

It is the duty of the technical personnel to use the documentation published at the respective time of each installation and commissioning.

The responsible staff must ensure that the application or use of the products described satisfy all the requirements for safety, including all the relevant laws, regulations, guidelines and standards.

Disclaimer

The documentation has been prepared with care. The products described are, however, constantly under development.

We reserve the right to revise and change the documentation at any time and without prior announcement. No claims for the modification of products that have already been supplied may be made on the basis of the data, diagrams and descriptions in this documentation.

Trademarks

Beckhoff®, TwinCAT®, TwinCAT/BSD®, TC/BSD®, EtherCAT®, EtherCAT G®, EtherCAT G10®, EtherCAT P®, Safety over EtherCAT®, TwinSAFE®, XFC®, XTS® and XPlanar® are registered trademarks of and licensed by Beckhoff Automation GmbH.

Other designations used in this publication may be trademarks whose use by third parties for their own purposes could violate the rights of the owners.

Patent Pending

The EtherCAT Technology is covered, including but not limited to the following patent applications and patents:

EP1590927, EP1789857, EP1456722, EP2137893, DE102015105702
with corresponding applications or registrations in various other countries.



EtherCAT® is a registered trademark and patented technology, licensed by Beckhoff Automation GmbH, Germany

Copyright

© Beckhoff Automation GmbH & Co. KG, Germany.

The reproduction, distribution and utilization of this document as well as the communication of its contents to others without express authorization are prohibited.

Offenders will be held liable for the payment of damages. All rights reserved in the event of the grant of a patent, utility model or design.

1.2 Safety instructions

Safety regulations

Please note the following safety instructions and explanations!
Product-specific safety instructions can be found on following pages or in the areas mounting, wiring, commissioning etc.

Exclusion of liability

All the components are supplied in particular hardware and software configurations appropriate for the application. Modifications to hardware or software configurations other than those described in the documentation are not permitted, and nullify the liability of Beckhoff Automation GmbH & Co. KG.

Personnel qualification

This description is only intended for trained specialists in control, automation and drive engineering who are familiar with the applicable national standards.

Description of symbols

In this documentation the following symbols are used with an accompanying safety instruction or note. The safety instructions must be read carefully and followed without fail!

DANGER

Serious risk of injury!

Failure to follow the safety instructions associated with this symbol directly endangers the life and health of persons.

WARNING

Risk of injury!

Failure to follow the safety instructions associated with this symbol endangers the life and health of persons.

CAUTION

Personal injuries!

Failure to follow the safety instructions associated with this symbol can lead to injuries to persons.

NOTE

Damage to the environment or devices

Failure to follow the instructions associated with this symbol can lead to damage to the environment or equipment.



Tip or pointer

This symbol indicates information that contributes to better understanding.

2 Installation

The kinematics package integrates itself transparently into the existing Motion Control world of TwinCAT: simple insertion of an additional Kinematic channel is sufficient. The complete parameterization is done in the TwinCAT System Manager. The package supports different parallel and serial kinematic systems, as used for e.g. Pick & Place tasks.

The supplement is based on TwinCAT NC I for interpolating movements and G-Code (DIN 66025). In addition, standard PTP and cam plate applications can be realized. Programming is usually based on the Cartesian coordinate system, with the control system calculating the inverse kinematics for the relevant motor positions. The kinematic system can be selected in the TwinCAT System Manager. The kinematic channel is used to parameterize the type (e.g. delta) and the bar lengths and offsets. Mass and mass inertia values can be specified for dynamic pre-control. The “flying saw” and “cam plate” functions enable synchronization with conveyor belts for picking or placing work pieces, for example.

Installation Requirements

The supplement TwinCAT Kinematic Transformation requires TwinCAT **NCI-Level** and at least Version 2.11 R3. It runs generally on Windows XP/Vista/7 and CE devices.

Installation Levels

TwinCAT Kinematic Transformation is divided in 4 different levels, depending on the transformation's number of axes. A higher level includes all sub-levels.

Level 1

Supports the static transformation. This includes a translation and rotation of the coordinate system.

Level 2

Supports level 1 and easy (mainly 2D) kinematic transformation like H-Bot and 2D-Parallel-Kinematics.

Level 3

Supports level 2 and more complex (3D,4D) kinematic transformation like Delta-Robot.

Level 4

Supports level 3 and complex kinematic transformation (up to 6D).

3 Configuration

Based on the PLCopen we distinguish two main coordinate systems:

- **Axis Coordinate System (ACS)**
The axes of the ACS are connected to the real motor. So this coordinate system represents the positioning of the motor without taking care about the position of the tool center point (TCP).
- **Machine Coordinate System (MCS)**
this is by default a Cartesian coordinate system. Programming of movements are usually done here and therefore the axes X, Y, and Z are used. The backward transformation is calculating the positions for the axes coordinate system. The axes in MCS are pure software axes and of type simulation encoder.

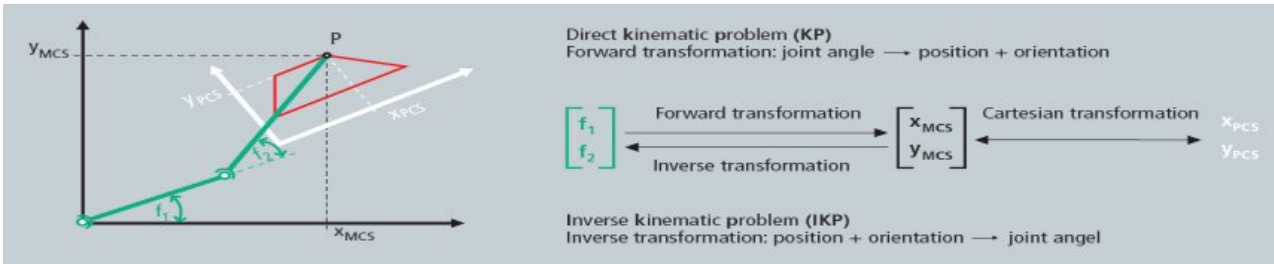

All ACS and MCS axes that are used in a kinematic transformation channel must be created in the System Manager. So for example a Delta-Robot will have 3 ACS axes (M1...M3) and 3 MCS axes (X, Y, Z).

Configure Kinematic Transformation Channel

1. Append all axes (ACS and MCS) to the NC-Configuration in System Manager equal to PTP axes.

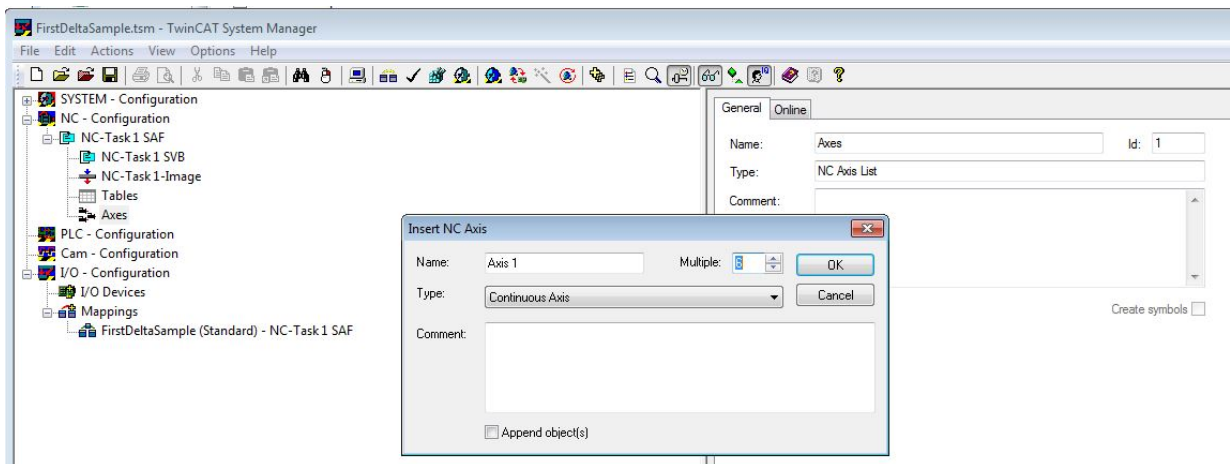

2. Append a kinematic channel to the System Manager configuration.

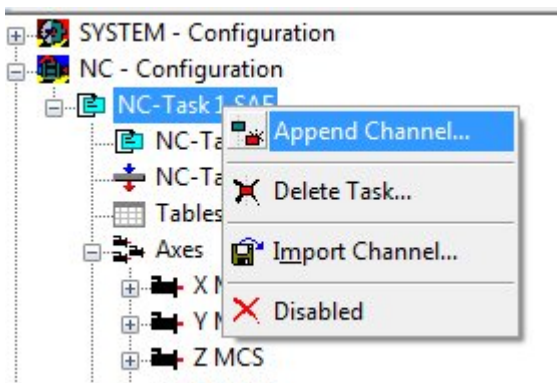

⇒ Appending a channel creates an instance of the kinematic group.

3. Select the channel type: **NC-Channel (for Kinematic Transformation)** to run a kinematic transformation.

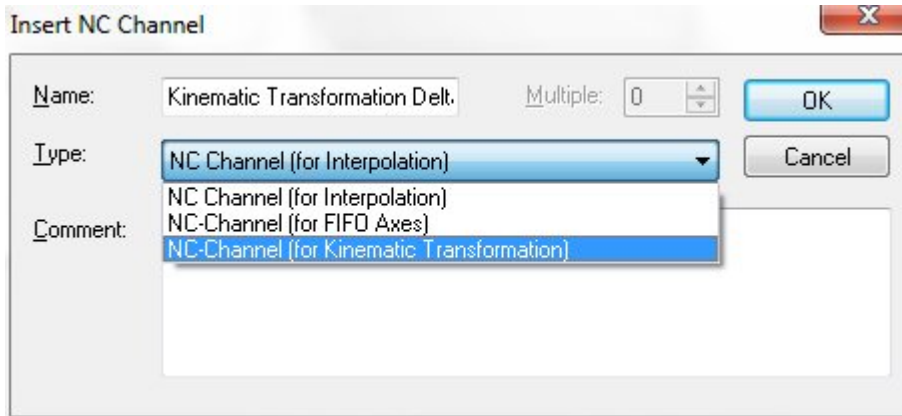

4. Append the objects under the group that represent the user's kinematic configuration.

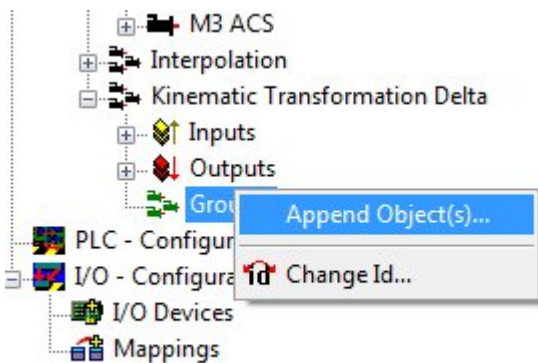

5. Browse for **TcNcKin.tmc** in TwinCAT\IO-Folder.
6. To start-up for instance the transformation for a delta-robot select
 - Delta Type 1
 - Static-Trafo 6D (optional MCS shift)

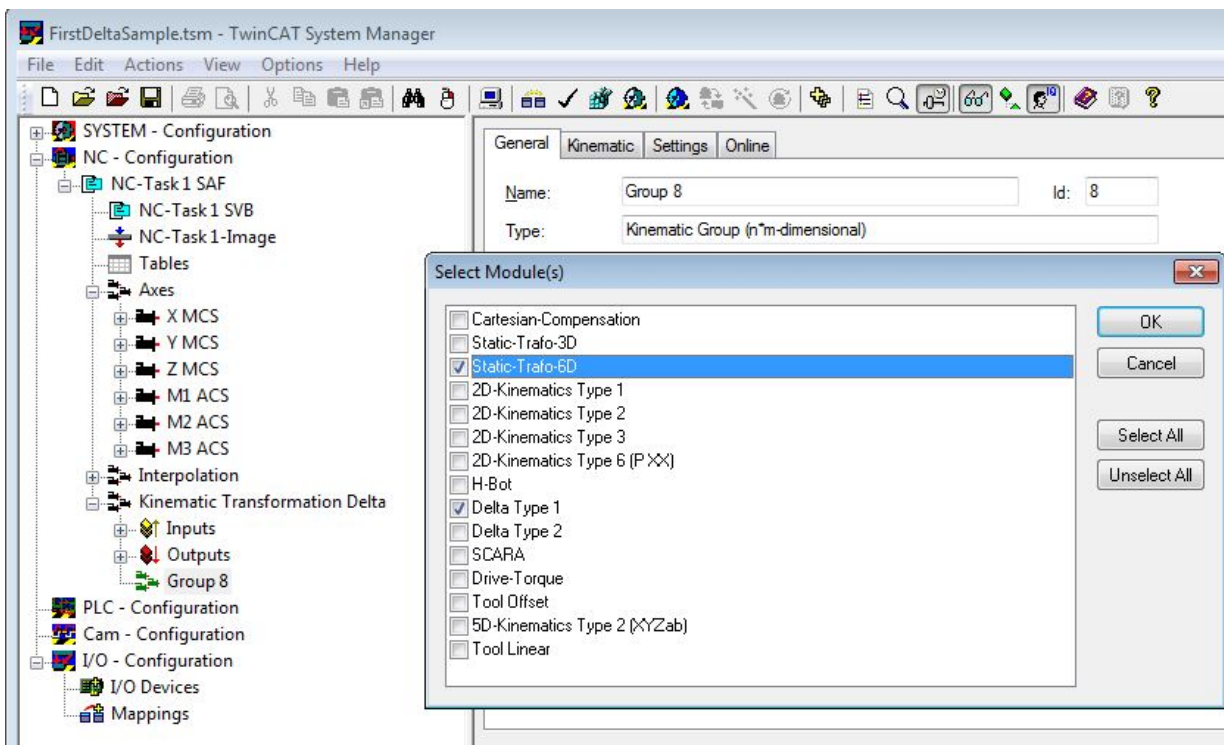

- The transformation group has to know what root module has to be called. Therefore the object ID of the kinematics (in this case Delta Type1) must be selected. The kinematic object defines the number of ACS and MCS axes to be used in PLC (cf. [ST_KinAxes](#) [▶ 36]).

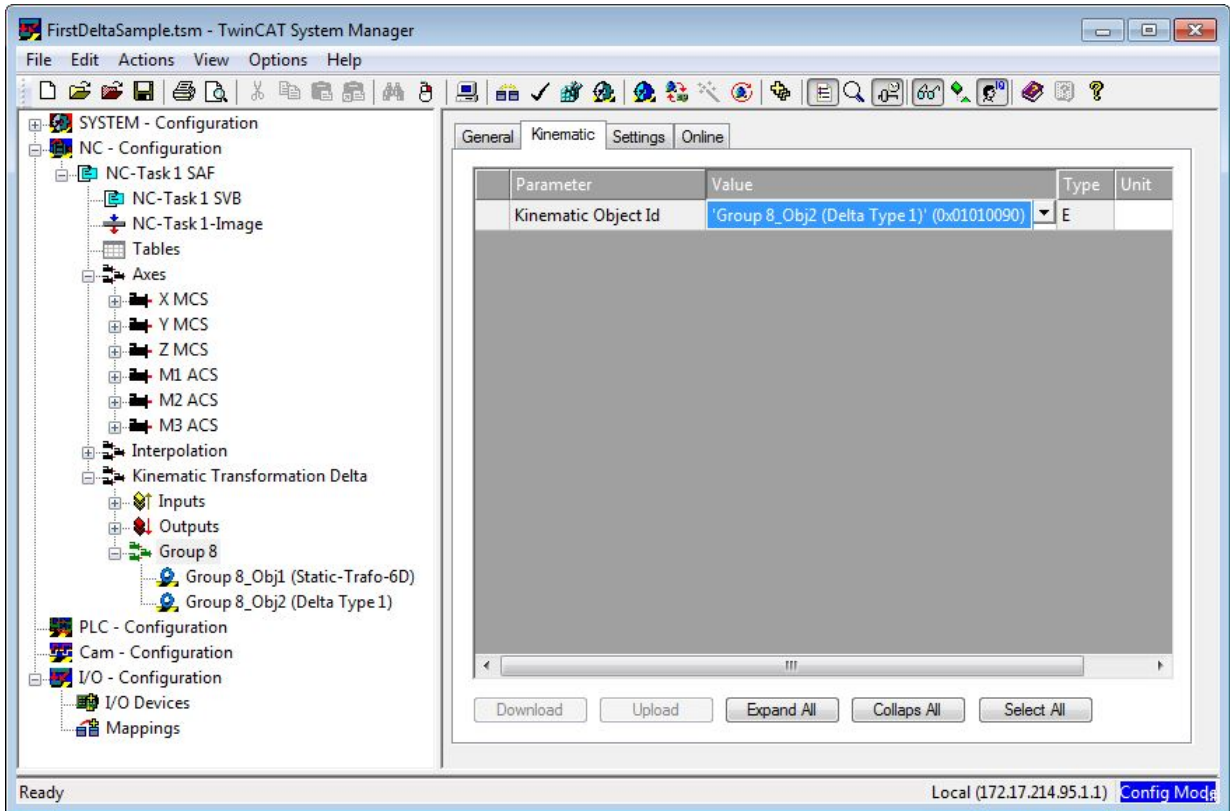

- Parameterize the objects parameters to the used kinematics.

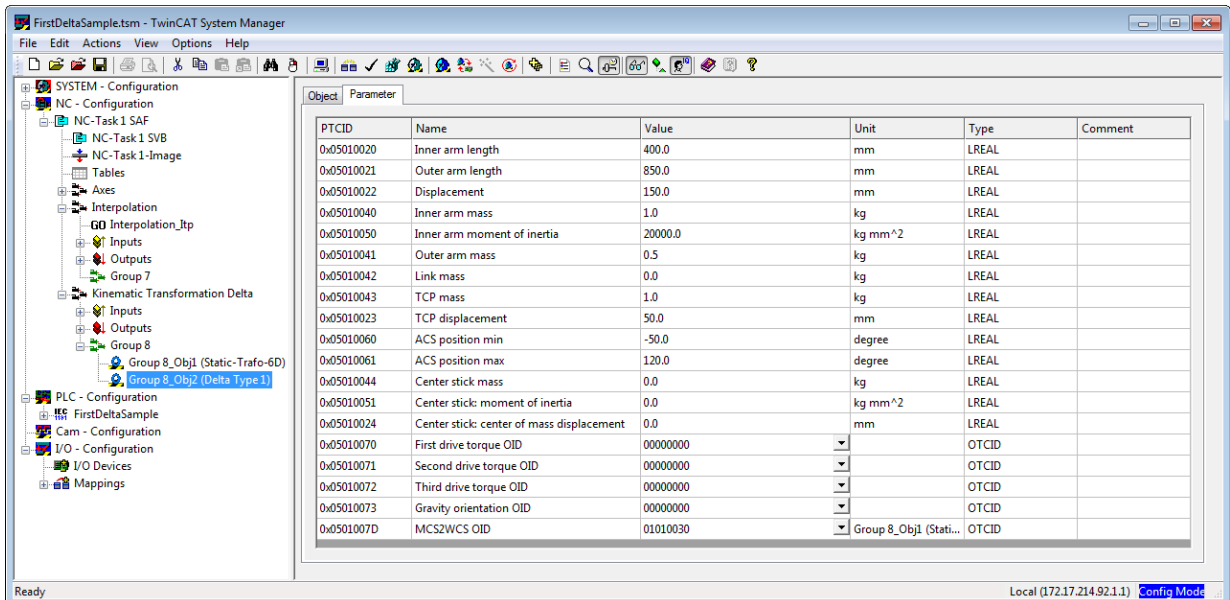





⇒ After this the System Manager configuration is done.

- The Transformation can now be activated from PLC (cf. [Plc Library](#) [▶ 23]). To address the transformation define a cyclical channel interface in the PLC and link it to the kinematic channel's I/O.

```
in_stKinToPlc      AT %I*      : NciChannelToPlc;
out_stPlcToKin     AT %Q*      : NciChannelFromPlc;
```

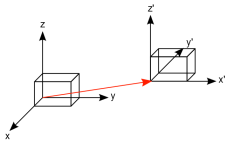
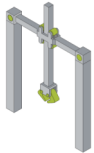
4 Supported Transformations

Overview

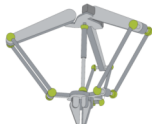
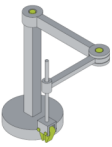
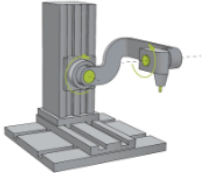
Transformation Type	Scheme	Required Level and Version
Static Transformation (3D, 6D) [▶ 12]		Level 1 Version 2.11.0 Build 3
H-Bot [▶ 13]		Level 2 Version 2.11.0 Build 3
2D-Type 1 [▶ 14]		Level 2 Version 2.11.0 Build 3
2D-Type 2 [▶ 15]		Level 2 Version 2.11 Build 6
2D-Type 3 [▶ 16]		Level 2 Version 2.11 Build 6
2D-Kinematics Type 6 (P XX)		Level 2
Delta Type 1 [▶ 17]		Level 3 Version 2.11.0 Build 3
Delta Type 2		Level 3
SCARA [▶ 19]		Level 3
5D-Kinematics Type 2 (XYZab) [▶ 19]		Level 4

Additional Objects

Object type	Description	Required Level and Version
Static Transformation (3D, 6D) [▶ 12]	Describes a user defined coordinate system.	Level 1

Object type	Description	Required Level and Version
Tool Offset [► 21]	Describes a tool at the kinematics flange.	Level 1
Tool Linear [► 22]	Describes a 1D tool attached to the kinematics flange which offers the possibility to move TCP in tool direction.	Level 1
Drive Torque [► 21]	Represents the inertia and efficiency of motor and gear box to calculate the dynamic model more precisely.	Level 1

4.1 Static Transformation

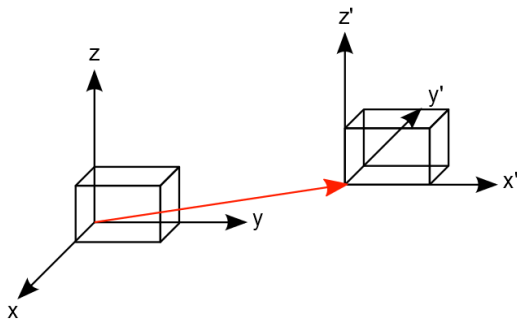

The static transformation supports a translation and rotation. By using this transformation, it is possible to define a User Coordinate System (UCS). This module takes care of the transformation from UCS to the Machine Coordinate System (MCS).

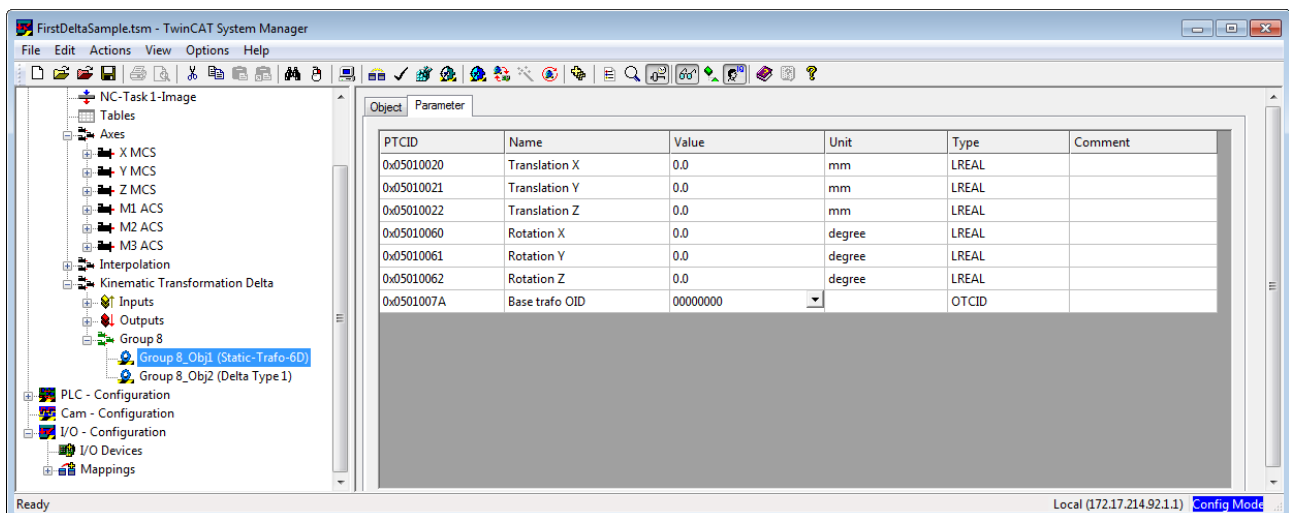

The parameterization is done from MCS to UCS (forward transformation).

First the translation must be described and then the rotation is calculated. Therefore the yaw-pitch-roll-rule that is described in DIN9300 is used. The calculation sequence for the forward transformation is Z, Y', X''

Parameter	Description	Unit
Translation X	Shift in x direction from MCS to user defined coordinate system	mm
Translation Y	Shift in y direction from MCS to user defined coordinate system.	mm
Translation Z	Shift in z direction from MCS to user defined coordinate system	mm
Rotation X	Right handed rotation around the x''-axis in degree	degree

Parameter	Description	Unit
Rotation Y	Right handed rotation around the y'-axis in degree	degree
Rotation Z	Right handed rotation around the z-axis in degree	degree
Base Trafo OID	In case of a cascaded static transformation object id of the base transformation is parameterized here	

4.2 H-Bot

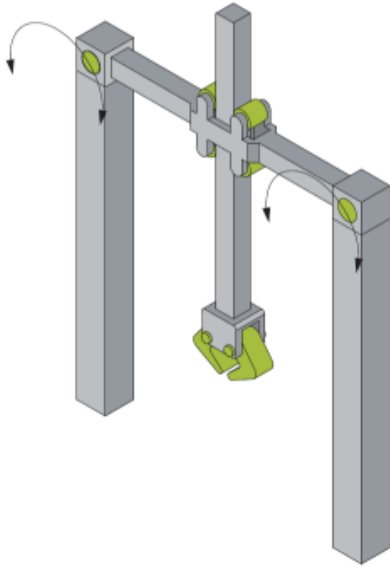

The H-Bot is built up as shown in the schema above.

The motor axes have to be scaled in mm representing the cable length at each side of the TCP. To calculate the transformation the relative cable movements are sufficient and no absolute cable lengths are needed.

The origin of the machine coordinate system is defined by the point where the position of both motors is zero.

Parameter for kinematics

Parameter	Description	Unit
MCS2WCS OID	Object ID of a static transformation which defines the position of MCS in base coordinate system (normally WCS).	

Parameter for dynamic model

Parameter	Description	Unit
FirstDriveTorqueOID	Object ID of the first drive torque If motors and gear boxes for all motors behaves similar, all drive torques can be represented by one OID. So both parameters refer to the same object ID.	
SecondDriveTorqueOID	Object ID of the second drive torque	
GravityOrientationOID	Object ID of a static transformation that describes the mounting orientation. This parameter is used if the gripper does not show to the ground. The static transformation's Z-axis defines the gravity orientation. If the robot is mounted as shown in the picture this OID can be zero.	

4.3 2-D-Kinematics Type 1

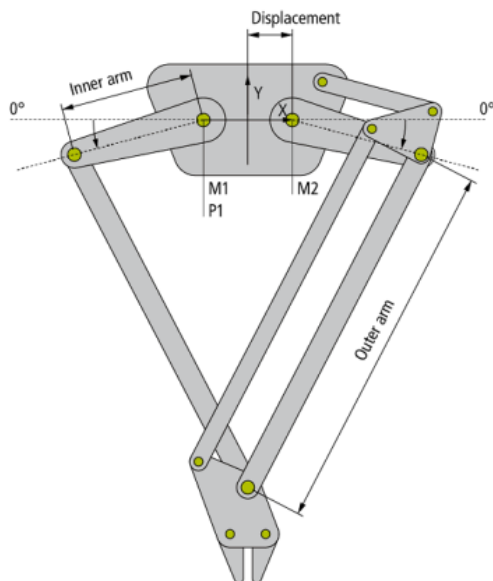

The 2-D-kinematics type 1 is built up as shown in the schema above.

All motor axes are scaled in degree and 0° is defined as shown in the schema with positive direction in direction of the arrow.

Parameter for kinematics

Parameter	Description	Unit
InnerArmLength	Length from pivot point to pivot point of the inner arm.	mm
OuterArmLength	Length from pivot point to pivot point of the outer arm.	mm
Displacement	Length from center of the ground plate to the virtual rotary axes of the inner arm	mm
MCS2WCS OID	Object ID of a static transformation which defines the position of MCS in base coordinate system (normally WCS).	

Parameter for dynamic model

Parameter	Description	Unit
InnerArmMass	Total mass of the inner arm	kg
InnerArmMomentOfInertia	Moment of inertia of the inner arm related to the turning point P1 that is connected to the motor	kg mm ²
OuterArmMass	Mass of the outer arm. Optionally the link mass can be described in an own parameter	kg
FirstLinkMass	Mass of the link that connects inner and outer arm. Can be used if the link mass is not yet included to outer and inner arms. The link mass that connects the gripper plate and the outer arm is not specified here. That can be added to the TcpMass First link mass is related to the inner arm that is linked to motor 1	kg
SecondLinkMass	cf. FirstLinkMass Second link mass is related to the inner arm that is linked to motor 2	kg
TcpMass	Mass of the tool center point including gripper plate and gripper. The payload is usually written to a separate parameter.	kg

Parameter	Description	Unit
FirstDriveTorqueOID	Object ID of the first drive torque If motors and gear boxes for all motors behaves similar, all drive torques can be represented by one OID. So both parameters refer to the same object ID.	
SecondDriveTorqueOID	Object ID of the second drive torque	
GravityOrientationOID	Object ID of a static transformation that describes the mounting orientation. This parameter is used if the gripper does not show to the ground. The static transformation's Z-axis defines the gravity orientation. If the robot is mounted as shown in the picture this OID can be zero.	

Required Product Level:
Level 2

4.4 2-D-Kinematics Type 2

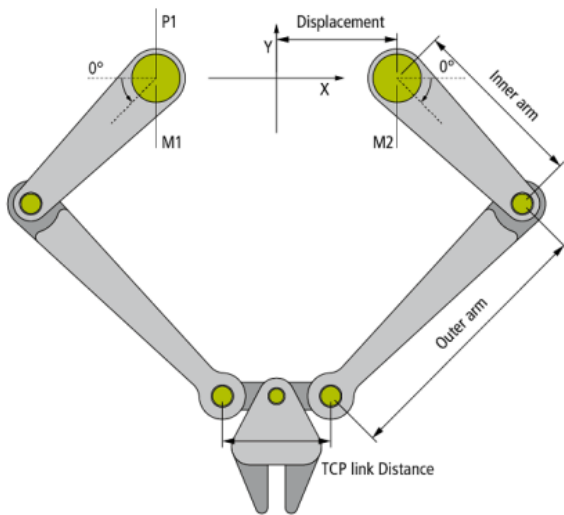

The 2-D-kinematics type 2 is built up as shown in the schema above.

All motor axes are scaled in degree and 0° is defined as shown in the schema with positive direction in direction of the arrow.

Parameter for kinematics

Parameter	Description	Unit
InnerArmLength	Length from pivot point to pivot point of the inner arm.	mm
OuterArmLength	Length from pivot point to pivot point of the outer arm.	mm
Displacement	Length from center of the ground plate to the virtual rotary axes of the inner arm	mm
TcpLinkDistance	Distance from pivot point to pivot point of the outer arms	mm
MCS2WCS OID	Object ID of a static transformation which defines the position of MCS in base coordinate system (normally WCS).	

Parameter for dynamic model

Parameter	Description	Unit
InnerArmMass	Total mass of the inner arm	kg
InnerArmMomentOfInertia	Moment of inertia of the inner arm related to the turning point P1 that is connected to the motor	kg mm ²

Parameter	Description	Unit
OuterArmMass	Mass of the outer arm. Optionally the link mass can be described in an own parameter	kg
FirstLinkMass	Mass of the link that connects inner and outer arm. Can be used if the link mass is not yet included to outer and inner arms. The link mass that connects the gripper plate and the outer arm is not specified here. That can be added to the TcpMass First link mass is related to the inner arm that is linked to motor 1	kg
SecondLinkMass	cf. FirstLinkMass Second link mass is related to the inner arm that is linked to motor 2	kg
TcpMass	Mass of the tool center point including gripper plate and gripper. The payload is usually written to a separate parameter.	kg
FirstDriveTorqueOID	Object ID of the first drive torque If motors and gear boxes for all motors behaves similar, all drive torques can be represented by one OID. So both parameters refer to the same object ID.	
SecondDriveTorqueOID	Object ID of the second drive torque	
GravityOrientationOID	Object ID of a static transformation that describes the mounting orientation. This parameter is used if the gripper does not show to the ground. The static transformation's Z-axis defines the gravity orientation. If the robot is mounted as shown in the picture this OID can be zero.	

Required Product Level:
Level 2

4.5 2-D-Kinematics Type 3

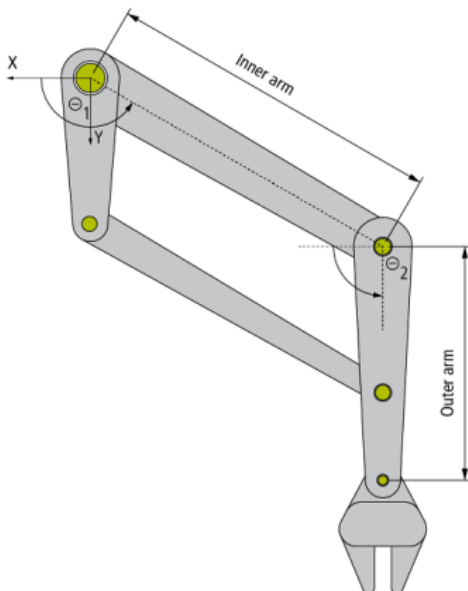

The 2-D-kinematics type 3 is built up as shown in the schema above.

All motor axes are scaled in degree and 0° is defined as shown in the schema with positive direction in direction of the arrow.

This kinematic type is implemented as left handed. The shaft of motor 1 & 2 are located in the origin of the coordinate system.

Parameter for kinematics

Parameter	Description	Unit
InnerArmLength	Length from motor shaft to pivot point of the outer arm.	mm
OuterArmLength	Length from pivot point to tool center point of the outer arm.	mm
MCS2WCS OID	Object ID of a static transformation which defines the position of MCS in base coordinate system (normally WCS).	

Parameter for dynamic model

Parameter	Description	Unit
InnerArmMass	Total mass of the inner arm	kg
OuterArmMass	Mass of the outer arm.	kg
ToolCenterpointMass	Mass of the tool center point including gripper plate and gripper. The payload is usually written to a separate parameter.	kg
FirstDriveTorqueOID	Object ID of the first drive torque If motors and gear boxes for all motors behaves similar, all drive torques can be represented by one OID. So both parameters refer to the same object ID.	
SecondDriveTorqueOID	Object ID of the second drive torque	
GravityOrientationOID	Object ID of a static transformation that describes the mounting orientation. This parameter is used if the gripper does not show to the ground. The static transformation's Z-axis defines the gravity orientation. If the robot is mounted as shown in the picture this OID can be zero.	

Required Product Level:
Level 2

4.6 Delta Type 1

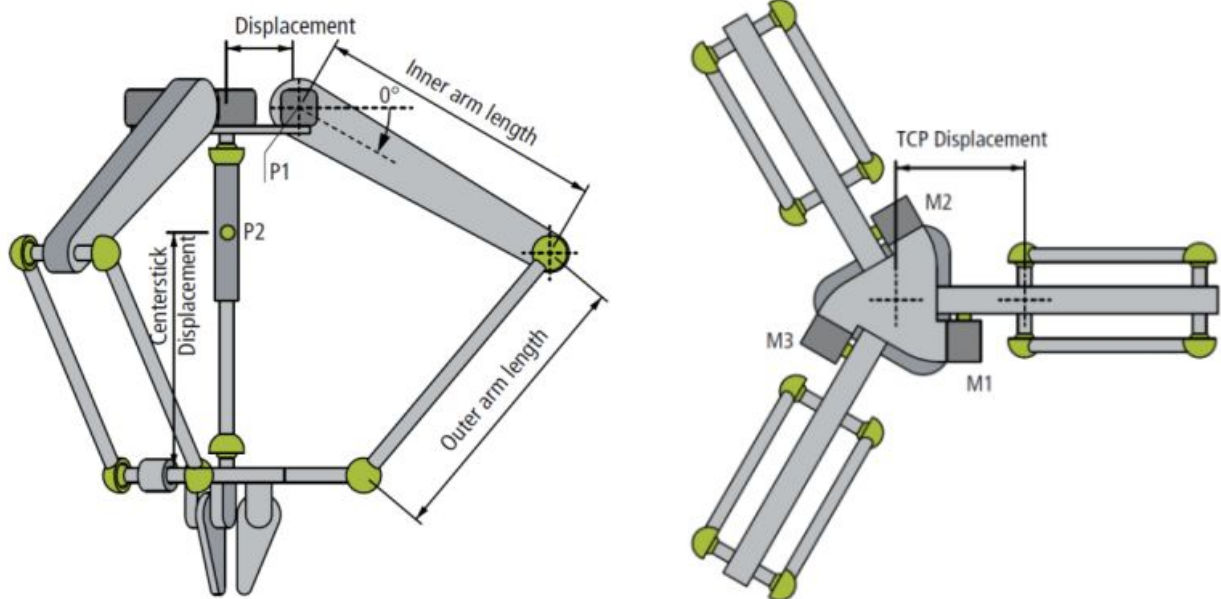

The delta kinematics type 1 is built up as shown in the schema above. The kinematic transformation expects ball joints (or elements with the same behavior) in the connection of the arms and to the lower plate.

Optionally the center stick for the orientation of the gripper can be parameterized.

All motor axes are scaled in degree and 0° is defined as shown in the schema with positive direction in direction of the arrow. That is for all 3 motors the same.

Parameter for kinematics

Parameter	Description	Unit
InnerArmLength	Length from pivot point to pivot point of the inner arm. That is the arm which is directly linked to the motor	mm
OuterArmLength	Length from pivot point to pivot point of the outer arm.	mm
Displacement	Length from center of the ground plate to the virtual rotary axes of the inner arm	mm
TcpDisplacement	Length from center of the gripper plate to the virtual rotary axes of the outer arm	mm
MCS2WCS OID	Object ID of a static transformation which defines the position of MCS in base coordinate system (normally WCS).	

Parameter for dynamic model

Parameter	Description	Unit
InnerArmMass	Total mass of the inner arm	kg
InnerArmMomentOfInertia	Moment of inertia of the inner arm related to the turning point P1 that is connected to the motor	kg mm ²
OuterArmMass	Mass of the outer arm. If there are 2 rods the total mass is required. Optionally the link mass can be described in an own parameter	kg
LinkMass	Mass of the link that connects inner and outer arm. Can be used if the link mass is not yet included to outer and inner arms. The link mass that connects the gripper plate and the outer arm is not specified here. That can be added to the TcpMass	kg
TcpMass	Mass of the tool center point including gripper plate and gripper. The payload is usually written to a separate parameter.	kg
CenterStickMass	Total mass of the center stick	kg
CenterStickMomentOfInertia	Moment of inertia of the center stick related to the center of gravity (P2)	kg mm ²
CenterStickCenterOfMassDisplacement	Length from gripper plate to center of gravity of the stick.	mm
FirstDriveTorqueOID	Object ID of the first drive torque If motors and gear boxes for all motors behaves similar, all drive torques can be represented by one OID. So all 3 parameters refer to the same object ID.	
SecondDriveTorqueOID	Object ID of the second drive torque	
ThirdDriveTorqueOID	Object ID of the third drive torque	
GravityOrientationOID	Object ID of a static transformation that describes the mounting orientation. This parameter is used if the gripper does not show to the ground. The static transformation's Z-axis defines the gravity orientation. If the robot is mounted as shown in the picture this OID can be zero.	

Required Product Level:
Level 3

4.7 SCARA

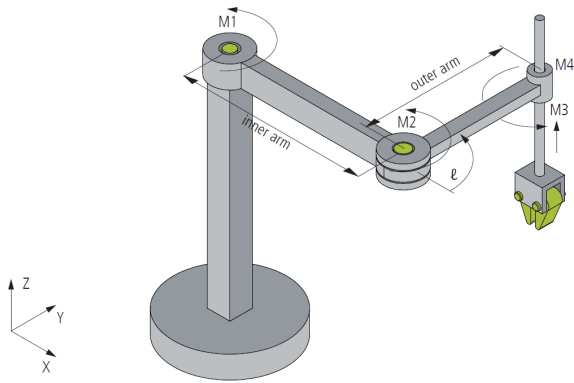

The SCARA (Selective Compliance Assembly Robot Arm) kinematics is built up as shown in the schema above.

The motor axes 1, 2 and 4 are scaled in degree with positive direction in direction of the arrow. The third motor axis is scaled in mm.

The origin of the MCS is set at the first joint (M1). The x-axis is defined by the SCARA arm when all rotary motor axes are 0°.

Parameter for kinematics

Parameter	Description	Unit
Inner arm length	Length from pivot point to pivot point of the inner arm. This is the arm at the side of the base.	mm
Outer arm length	Length from pivot point to pivot point of the outer arm. This is the arm at the side of the TCP	mm
Tool offset	Object ID of a tool attached at the flange of the kinematics.	
MCS2WCS OID	Object ID of a static transformation which defines the position of MCS in base coordinate system (normally WCS).	

Required Product Level:
Level 3

4.8 5D-Kinematics Type 2 (XYZab)

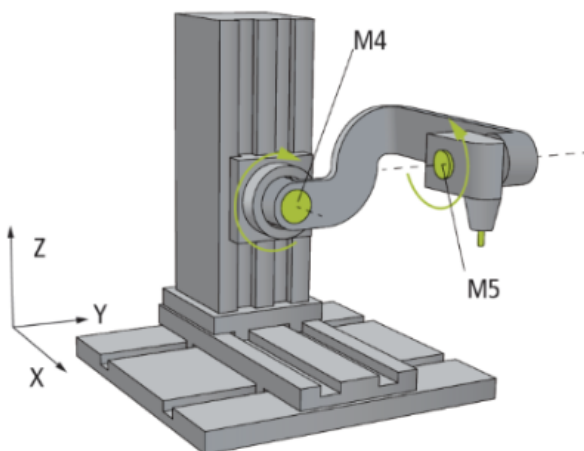

The 5D-kinematics type 2 is built up as shown in the schema above.

Motor axes 1-3 (X, Y, Z) are scaled in mm. Motor axes 4 and 5 are scaled in degree. 0° is defined as shown in the schema with positive rotation direction in direction of the arrows.

Parameter for kinematics

Parameter	Description	Unit
D4	Arm length in direction of x from motor axis 4 to motor axis 5 as illustrated in picture.	mm
Offset 4	Offset in direction of y between motor axis 4 and TCP	mm
Offset 5	Offset in direction of x between motor axis 5 and TCP	mm
Offset 6	Offset in direction of z between motor axis 4 and motor axis 5	mm
Tool offset OID	Object ID of a tool attached at the flange of the kinematics.	
MCS2WCS OID	Object ID of a static transformation which defines the position of MCS in base coordinate system (normally WCS).	

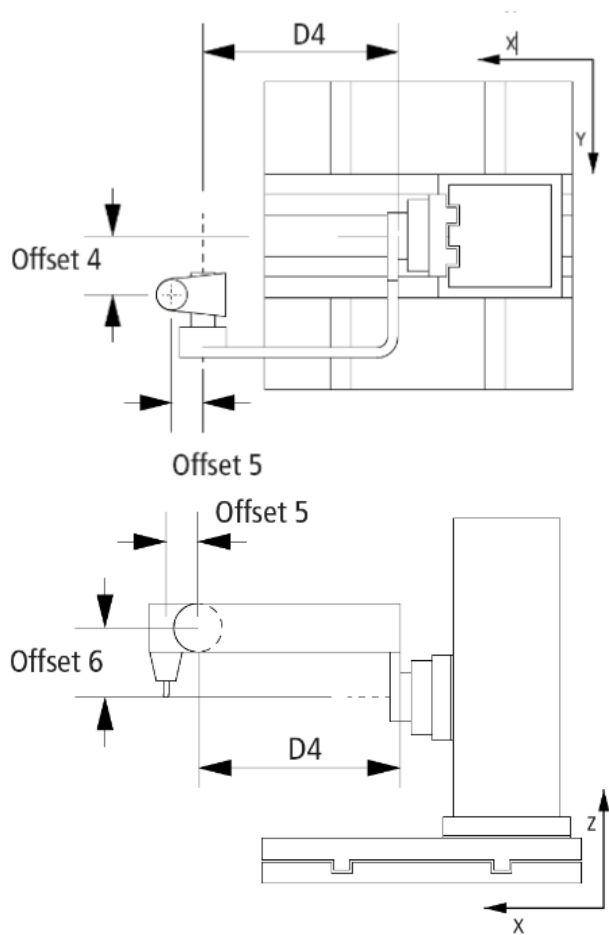

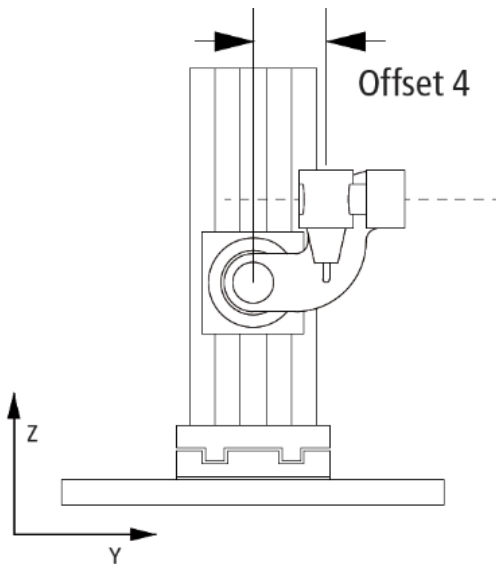

Required Product Level:
Level 4

4.9 Drive Torque

The drive torque represents the inertia and efficiency of motor and gear box. This is used for a precise calculation of the dynamic model.

Parameter for drive

Parameter	Description	Unit
Drive moment of inertia	Rotor Moment of inertia of the motor	kg mm ²

Parameter for gear box

Parameter	Description	Unit
Ratio	Ratio of gear box	kg mm ² s ²
Gearbox moment of inertia	Moment of inertia of the gear box related to the drive	kg mm ²
Coulomb friction	Represents the kinetic ratio of friction	Nm
Stokes friction	Represents the velocity proportional ratio of friction	Nms

Required Product Level:
Level 1

4.10 Tool Offset

The tool offset allows the user to connect a tool to the kinematics.

Parameter	Description	Unit
Extension X	X-Offset of static tool attached to the flange coordinate frame of the parent transformation	mm
Extension Y	Y-Offset of static tool attached to the flange coordinate frame of the parent transformation	mm
Extension Z	Z-Offset of static tool attached to the flange coordinate frame of the parent transformation	mm

4.11 Tool Linear

Describes a 1D tool attached to the kinematics. By using an additional simulation axis it is possible to move in tool direction. The linear tool can be used to move the TCP in a defined distance of a work piece.

When the axis position is 0 the TCP is at the position of the tool offset.

Parameter	Description	Unit
Tool offset	Length of the tool	mm
Tool axis ID	Axis ID of a simulation axis. By moving this axis the TCP moves in direction of the linear tool.	

5 Plc Library

Function block	Description
Kinematic Transformation	
FB_ConfigKinGroup [▶ 23]	Configures ACS and MCS axes to the kinematic transformation group and activates Cartesian or joint mode
FB_ResetKinGroup [▶ 25]	Resets the kinematic transformation group
FB_CheckActualKinStatus [▶ 27]	Reads the status of the kinematic transformation group acyclically
F_GetKinChnOperationState [▶ 34]	Reads the status of the kinematic transformation group cyclically
F_GetAcsMcsAxisIds [▶ 35]	Reads the active ACS and MCS axes of the kinematics group
Transformation calculation	
FB_CalcTrafo [▶ 29]	Calculates the kinematic transformation without connection to axes
FB_CalcMultiTrafo	Calculates the kinematic transformation for multiple poses
Editing Parameters and Coordinate Systems online	
FB_LockTrafoParam [▶ 33]	Locks the kinematic transformation group parameters, disables write access
FB_UnlockTrafoParam [▶ 31]	Unlocks the kinematic transformation group parameters, enables write access

Structures and Enums

Name	Description
ST_KinAxes [▶ 36]	Structure of ACS and MCS axes, which constitute a kinematics
E_KINSTATUS [▶ 37]	Status of the kinematic group (Enum)

Development Environment	Target System	PLC libraries to include
TwinCAT v2.11.2000	PC(i386)	TcNcKinematicTransformation.lib

5.1 Function Blocks

5.1.1 FB_ConfigKinGroup

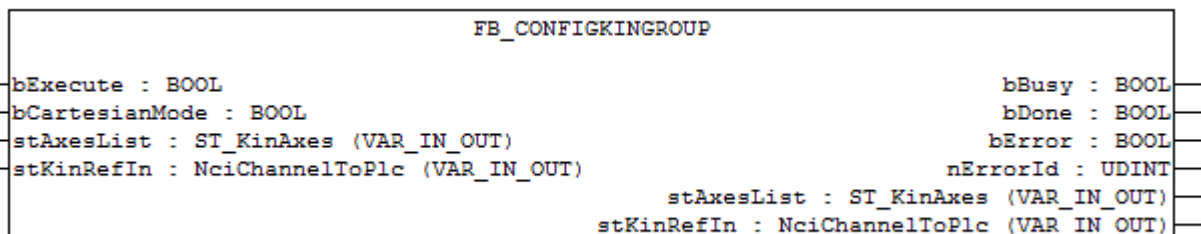

The Function Block FB_ConfigKinGroup configures axes to the kinematic transformation. These are axes for the ACS (Axis Coordinate System, Joint) and MCS (Machine Coordinate System, Cartesian). The Function Block takes the ACS and MCS Axes defined in the **stAxesList** and configures them into the kinematic group of **stKinRefIn**.

VAR_INPUT

```
VAR_INPUT
  bExecute          : BOOL;
  bCartesianMode    : BOOL;
END_VAR
```

bExecute: The command is triggered by a rising edge at this input.

bCartesianMode: If FALSE, the ACS (Axis Coordinate system, Joint) axes can be moved directly. If TRUE, movement in the MCS (Cartesian) axes will be transformed into the ACS (Joint) axes. The ACS axes cannot be moved directly.

VAR_IN_OUT

```
VAR_IN_OUT
  stAxesList        : ST_KinAxes;
  stKinRefIn        : NciChannelToPlc;
END_VAR
```

stAxesList: Determines the ACS and MCS axes included in the configuration. See [ST_KinAxes \[► 36\]](#).

stKinRefIn: Determines the kinematic group of the configuration. See [NciChannelToPlc](#).

VAR_OUTPUT

```
VAR_OUTPUT
  bBusy             : BOOL;
  bDone             : BOOL;
  bError            : BOOL;
  nErrorId          : UDINT;
END_VAR
```

bBusy: The output becomes TRUE when the command is started with *bExecute* as long as the function block is executing the command. While *bBusy* is TRUE, no new instructions will be accepted at the inputs. When *bBusy* becomes FALSE again, the function block is ready for a new command. At the same time one of the outputs *bDone* or *bError* is set.

bDone: The output becomes true if the command succeeded.

bError: The output *bError* becomes true if an error occurs as the command is executed.

nErrorId: Contains the command-specific error code of the most recently executed command. The error code can be found in the [ADS error documentation \[► 38\]](#) or in the NC error documentation (error codes above 0x4000).

Example

```
VAR
  io_X              : AXIS_REF;
  io_Y              : AXIS_REF;
  io_Z              : AXIS_REF;
  io_M1             : AXIS_REF;
  io_M2             : AXIS_REF;
  io_M3             : AXIS_REF;
  out_stPlcToKin AT %Q* : NciChannelFromPlc;
  out_stPlcToItp AT %Q* : NciChannelFromPlc;
  fbConfigKinGroup  : FB_ConfigKinGroup;
  stAxesConfig      : ST_KinAxes;
  bAllAxesReady     : BOOL;
  bExecuteConfigKinGroup: BOOL;
  bUserConfigKinGroup : BOOL;
  bUserCartesianMode : BOOL; := TRUE;
  (*true: cartesian mode - false: direct mode (without transformation) *)
END_VAR

(* read the IDs from the cyclic axis interface so the axes can mapped later to the kinematic group *)
stAxesConfig.nAxisIdsAcs[1] := io_M1.NcToPlc.AxisId;
stAxesConfig.nAxisIdsAcs[2] := io_M2.NcToPlc.AxisId;
stAxesConfig.nAxisIdsAcs[3] := io_M3.NcToPlc.AxisId;
stAxesConfig.nAxisIdsMcs[1] := io_X.NcToPlc.AxisId;
stAxesConfig.nAxisIdsMcs[2] := io_Y.NcToPlc.AxisId;
stAxesConfig.nAxisIdsMcs[3] := io_Z.NcToPlc.AxisId;
```



```

IF bAllAxesReady AND bUserConfigKinGroup THEN
  bExecuteConfigKinGroup := TRUE;
ELSE
  bExecuteConfigKinGroup := FALSE;
END_IF

fbConfigKinGroup(
  bExecute      := bExecuteConfigKinGroup ,
  bCartesianMode := bUserCartesianMode ,
  stAxesList    := stAxesConfig,
  stKinRefIn    := in_stKinToPlc );
  
```

Kinematic Group State

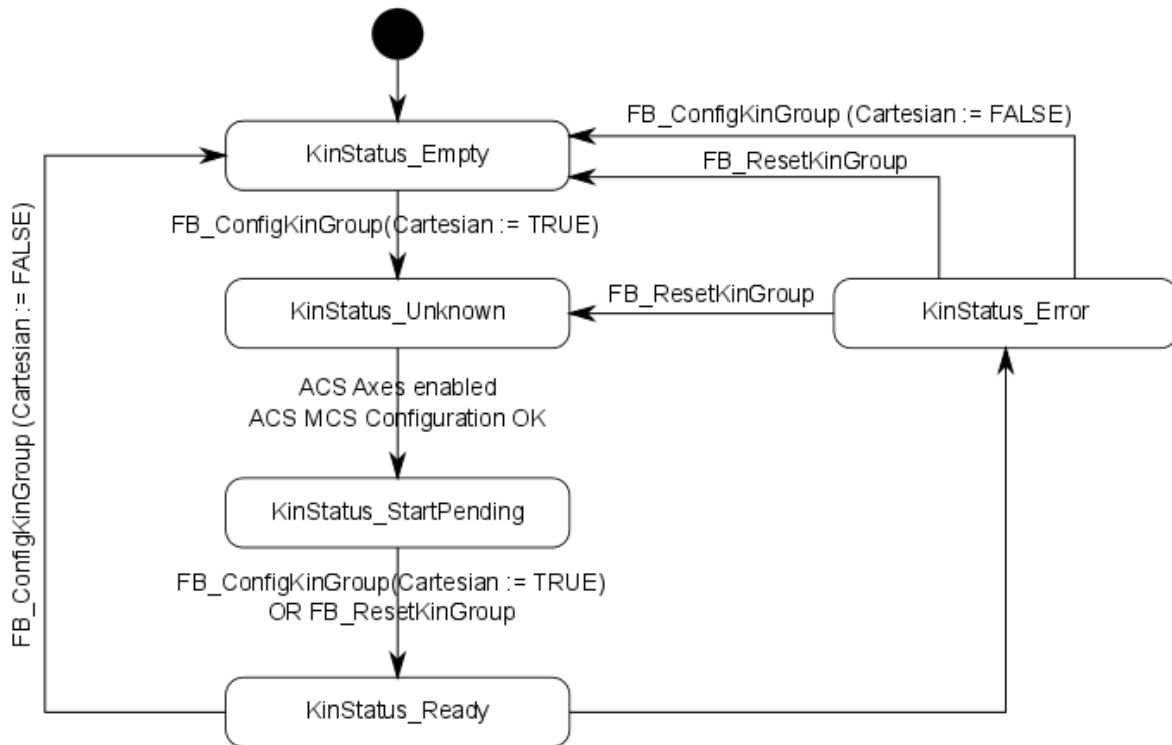

● Enabling Configuration

i The ACS axes must be enabled for the state to reach **KinStatus_Ready**. If the ACS Axes are not enabled, enable the axes and then call **FB_ConfigKinGroup** or **FB_ResetKinGroup**.

5.1.2 FB_ResetKinGroup

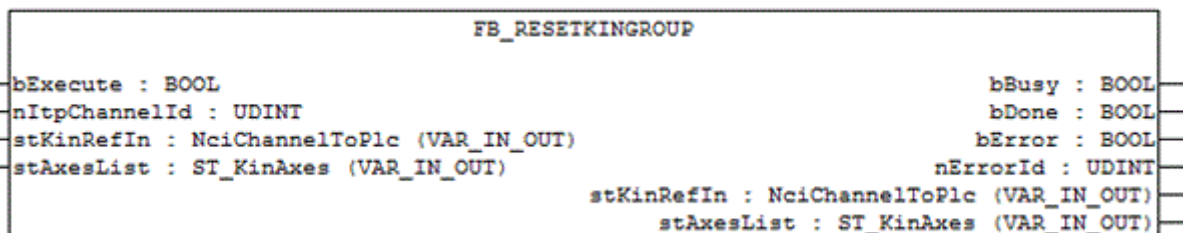

The Function Block **FB_ResetKinGroup** resets the Kinematic group. All ACS and MCS axes will be reset. Moreover, the input *nItpChannelId* can be used to specify the associated interpolation channel. The channel will be reset if the *nItpChannelId* is not 0.

If all axes are enabled and the group was in Cartesian Mode the group will return to KinStatus_Ready. If the group was not in Cartesian Mode the group will return to KinStatus_Empty. If the axes are not enabled the group will remain in KinStatus_Empty.

VAR_INPUT

```
VAR_INPUT
  bExecute      : BOOL;
  nItpChannelId : UDINT;
END_VAR
```

bExecute: The command is triggered by a rising edge at this input.

nItpChannelId: ID of the associated interpolation channel. If the input is not 0, the associated interpolation channel is reset.

VAR_IN_OUT

```
VAR_IN_OUT
  stAxesList      : ST_KinAxes;
  stKinRefIn      : NciChannelToPlc;
END_VAR
```

stAxesList: Determines the ACS and MCS axes included in the configuration. See [ST_KinAxes \[► 36\]](#).

stKinRefIn: Determines the kinematic group of the configuration. See [NciChannelToPlc](#).

VAR_OUTPUT

```
VAR_OUTPUT
  bBusy          : BOOL;
  bDone          : BOOL;
  bError         : BOOL;
  nErrorId       : UDINT;
END_VAR
```

bBusy: The output becomes TRUE when the command is started with *bExecute* as long as the function block is executing the command. While *bBusy* is TRUE, no new instructions will be accepted at the inputs. When *bBusy* becomes FALSE again, the function block is ready for a new command. At the same time one of the outputs *bDone* or *bError* is set.

bDone: The output becomes true if the command succeeded.

bError: The output *bError* becomes true if an error occurs as the command is executed.

nErrorId: Contains the command-specific error code of the most recently executed command. The error code can be found in the [ADS error documentation \[► 38\]](#) or in the NC error documentation (error codes above 0x4000).

Example

```
VAR
  fbFB_ResetKinGroup : FB_ResetKinGroup;
  stAxesConfig       : stAxesConfig;
  in_stKinToPlc AT %I* : NciChannelToPlc;
END_VAR

fbFB_ResetKinGroup(
  bExecute := TRUE,
  nItpChannelId := 3,
  stKinRefIn := in_stKinToPlc,
  stAxesList := stAxesConfig,
  bBusy=> ,
  bDone=> ,
  bError=> ,
  nErrorId=> );
```

Kinematic Group State

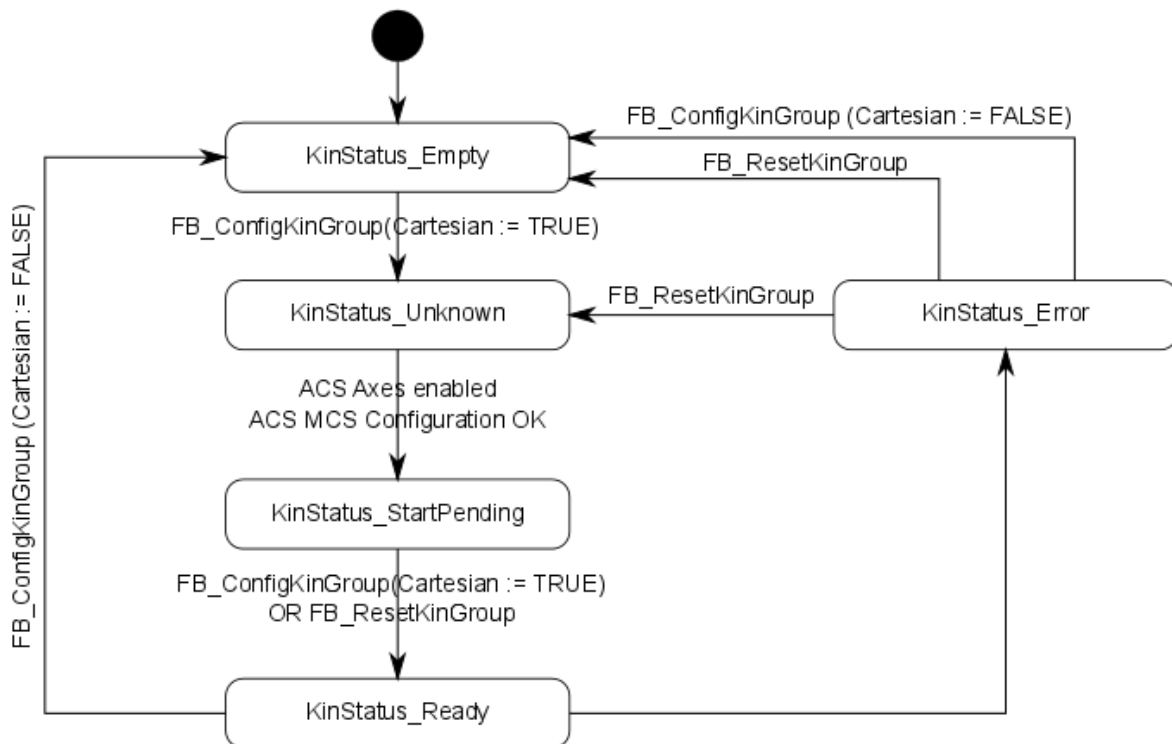

5.1.3 FB_CheckActualKinStatus

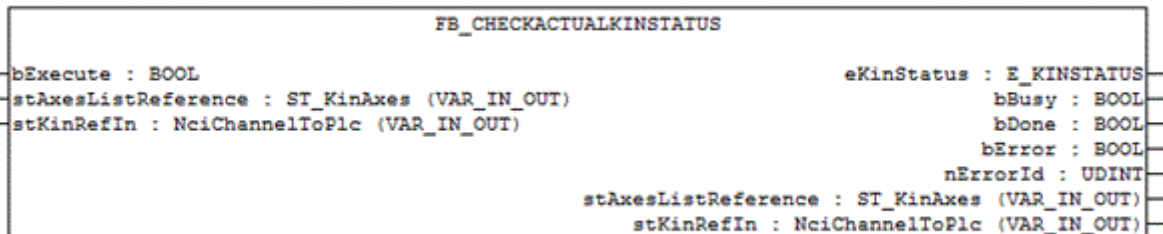

The Function Block FB_CheckActualKinStatus returns the status of the Kinematic channel.

i Getting the Kinematic channel status cyclically

This Function Block needs more than one PLC cycle to read the Kinematic channel status. To get it for every cycle use [F_GetKinChnOperationState \[► 34\]](#).

VAR_INPUT

```

VAR_INPUT
    bExecute : BOOL;
END_VAR
    
```

bExecute: The command is triggered by a rising edge at this input.

VAR_IN_OUT

```

VAR_IN_OUT
  stAxesList      : ST_KinAxes;
  stKinRefIn     : NciChannelToPlc;
END_VAR

```

stAxesList: Determines the ACS and MCS axes included in the configuration. See [ST_KinAxes \[► 36\]](#).

stKinRefIn: Determines the kinematic group of the configuration. See [NciChannelToPlc](#).

VAR_OUTPUT

```

VAR_OUTPUT
  eKinStatus      : E_KINSTATUS;
  bBusy           : BOOL;
  bDone           : BOOL;
  bError          : BOOL;
  nErrorId        : UDINT;
END_VAR

```

eKinStatus: Returns the status of the kinematic channel. See [E_KINSTATUS \[► 37\]](#)

bBusy: The output becomes TRUE when the command is started with *bExecute* as long as the function block is executing the command. While *bBusy* is TRUE, no new instructions will be accepted at the inputs. When *bBusy* becomes FALSE again, the function block is ready for a new command. At the same time one of the outputs *bDone* or *bError* is set.

bDone: The output becomes true if the command succeeded.

bError: The output *bError* becomes true if an error occurs as the command is executed.

nErrorId: Contains the command-specific error code of the most recently executed command. The error code can be found in the [ADS error documentation \[► 38\]](#) or in the NC error documentation (error codes above 0x4000).

Example

```

VAR
  fbFB_CheckActualKinStatus : FB_CheckActualKinStatus;
  in_stKinToPlc AT %I*      : NciChannelToPlc;
  stAxesConfig              : ST_KinAxes;
  eKinStatus                : E_KINSTATUS;
END_VAR

fbFB_CheckActualKinStatus (
  bExecute      := TRUE,
  stAxesListReference := stAxesConfig,
  stKinRefI     := in_stKinToPlc,
  eKinStatus    => eKinStatus );

```

Kinematic Group State

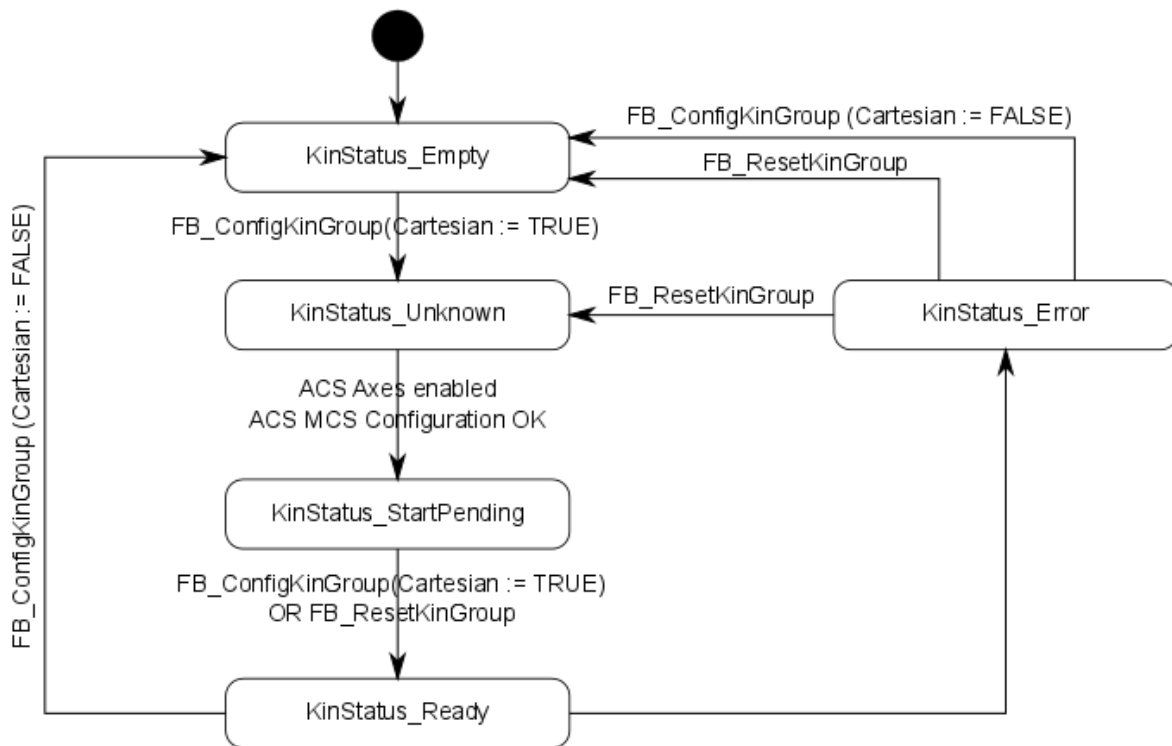

5.1.4 FB_CalcTrafo

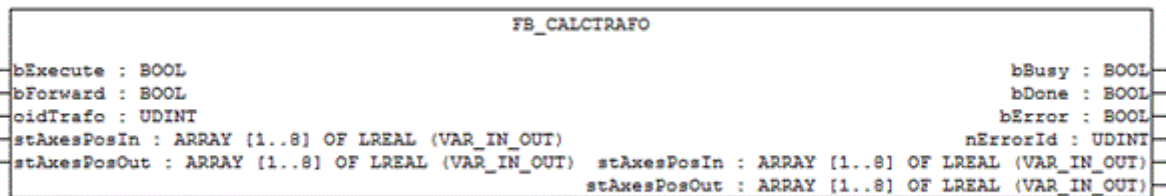

The Function Block FB_CalcTrafo calculates the forward or backward transformation even if no kinematic group is built with FB_ConfigKinGroup [► 23].

VAR_INPUT

```

VAR_INPUT
    bExecute      : BOOL;
    bForward      : BOOL;
    oidTrafo      : UDINT;
END_VAR
    
```

bExecute: The command is triggered by a rising edge at this input.

bForward: Determines whether the forward or backward transformation is calculated.

oidTrafo: Object-ID of the kinematic transformation object to be calculated. See [example \[► 30\]](#) below.

VAR_IN_OUT

```

VAR_IN_OUT
  stAxesPosIn      : ARRAY[1..8] OF LREAL;
  stAxesPosOut     : ARRAY[1..8] OF LREAL;
END_VAR

```

stAxesPosIn: Array which contains the input positions of the transformation. In order to calculate a forward transformation this would be the joint positions. In order to calculate a backward transformation this would be the Cartesian axes positions.

stAxesPosOut: Array which contains the resulting positions of the transformation. If a forward transformation is calculated this would be the Cartesian axes positions. If a backward transformation is calculated this would be the joint positions.

VAR_OUTPUT

```

VAR_OUTPUT
  bBusy           : BOOL;
  bDone           : BOOL;
  bError          : BOOL;
  nErrorId       : UDINT;
END_VAR

```

bBusy: The output becomes TRUE when the command is started with *bExecute* as long as the function block is executing the command. While *bBusy* is TRUE, no new instructions will be accepted at the inputs. When *bBusy* becomes FALSE again, the function block is ready for a new command. At the same time one of the outputs *bDone* or *bError* is set.

bDone: The output becomes true if the command succeeded.

bError: The output *bError* becomes true if an error occurs as the command is executed.

nErrorId: Contains the command-specific error code of the most recently executed command. The error code can be found in the [ADS error documentation](#) [▶ 38] or in the NC error documentation (error codes above 0x4000).

Example

The Scara Transformation has 4 ACS (joint) axes and 4 MCS (Cartesian) axes

Scara Transformation Example Configuration

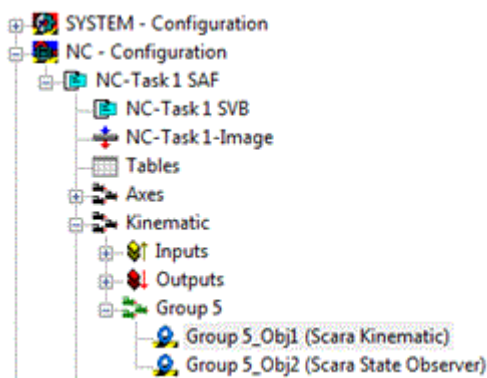

Object	Parameter			
PTCID	Name	Value	Unit	Type
0x05010020	InnerArmLength	430.0	mm	LREAL
0x05010021	OuterArmLength	370.0	mm	LREAL

Scara Transformation Example Object Id

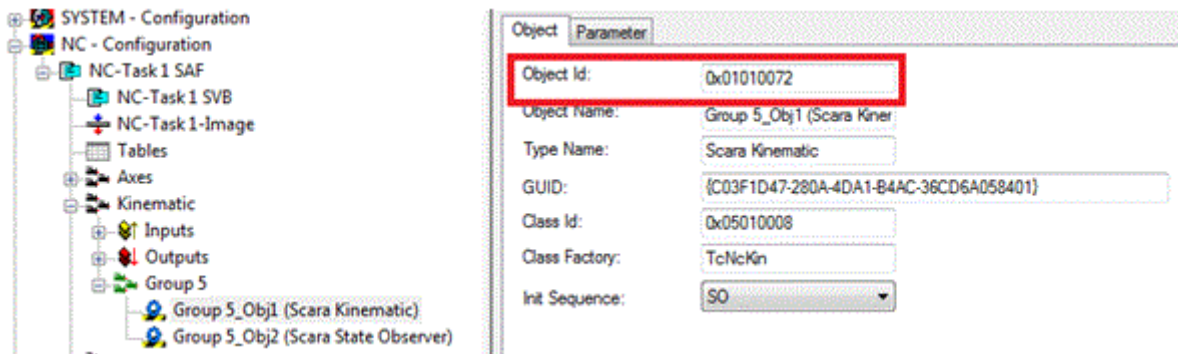

```

VAR
  fbFB_CalcTrafo      : FB_CalcTrafo;
  stAxesPosIn        : ARRAY[1..8] OF LREAL;
  stAxesPosOut       : ARRAY[1..8] OF LREAL;
  bUserExecute       : BOOL;
  bUserCalcFwdTrafo : BOOL;
END_VAR

fbFB_CalcTrafo(
  bExecute := bUserExecute,
  bForward := bUserCalcFwdTrafo,
  oidTrafo := 16#01010072,
  stAxesPosIn := stAxesPosIn,
  stAxesPosOut := stAxesPosOut,
  bBusy=> ,
  bDone=> ,
  bError=> ,
  nErrorId=> );
  
```

5.1.5 FB_UnlockTrafoParam

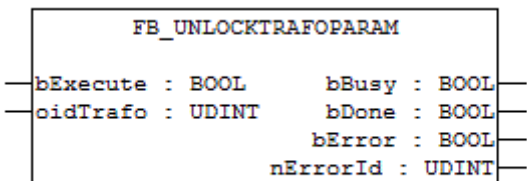

The Function Block FB_UnlockTrafoParam unlocks the transformation parameters so that they can be written.

After the Unlock the Kinematic Parameters can be written from the PLC with ADSWRITE. The required Index Group is the Object Id and the Index Offset is the Parameter Id. The written parameters are not persistent.

⚠ CAUTION	
Changing parameters may lead to discontinuities	
Beware this is to be used with extreme caution. Redefining kinematic parameters can introduce discontinuities in the Kinematic chain.	

VAR_INPUT

```

VAR_INPUT
  bExecute      : BOOL;
  oidTrafo     : UDINT;
END_VAR
  
```

bExecute: The command is triggered by a rising edge at this input.

oidTrafo: Object-ID of the kinematic transformation object. See [example](#) [▶ 32] below.

VAR_OUTPUT

```

VAR_OUTPUT
  bBusy          : BOOL;
  bDone          : BOOL;
  bError        : BOOL;
  nErrorId      : UDINT;
END_VAR

```

bBusy: The output becomes TRUE when the command is started with *bExecute* as long as the function block is executing the command. While *bBusy* is TRUE, no new instructions will be accepted at the inputs. When *bBusy* becomes FALSE again, the function block is ready for a new command. At the same time one of the outputs *bDone* or *bError* is set.

bDone: The output becomes true if the command succeeded.

bError: The output *bError* becomes true if an error occurs as the command is executed.

nErrorId: Contains the command-specific error code of the most recently executed command. The error code can be found in the [ADS error documentation \[► 38\]](#) or in the NC error documentation (error codes above 0x4000).

Example

The Object Id and Parameter Id needed to unlock and write a new value to a transformation parameter can be read from the Transformation Object in System Manager.

PTCID	Name	Value	Unit	Type
0x05010020	Inner arm length	380.0	mm	LREAL
0x05010021	Outer arm length	950.0	mm	LREAL
0x0501007C	Tool offset OID	00000000		OTCID
0x0501007D	MCS2WCS OID	00000000		OTCID

```

VAR
  bUserExecuteUnlock      : BOOL;
  fbFB_UnlockTrafoParam  : FB_UnlockTrafoParam;
  bUserExecuteWriteParam : BOOL;
  fbADSWRITE             : ADSWRITE;
  oidTrafo                : UDINT := 16#010100B0; (*Trafo object id*)
  pidTrafo                : UDINT := 16#05010020; (*parameter id*)
  fParamValue             : LREAL;
END_VAR

```

```

fbFB_UnlockTrafoParam(
  bExecute := bUserExecuteUnlock,
  oidTrafo := oidTrafo,
  bBusy=>,
  bDone=>,
  bError=>,
  nErrorId=> );

```

```

(*After unlocking new parameter value can be written*)
fbADSWRITE(
  NETID:= ' ',
  PORT:= AMSPORT_RO_NCSAF,
  IDXGRP:=oidTrafo ,
  IDXOFFS:= pidTrafo,

```



```
LEN:=SIZEOF(fParamValue) ,
SRCADDR:= ADR(fParamValue),
WRITE:=bUserExecuteWriteParam ,
TMOUT:= ,
BUSY=> ,
ERR=> ,
ERRID=> );
```

5.1.6 FB_LockTrafoParam

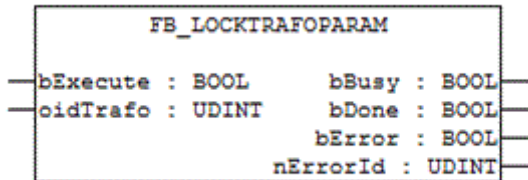

After changing transformation parameters by using [FB_UnlockTrafoParam \[► 31\]](#), the Function Block `FB_LockTrafoParam` locks the transformation parameters again, so they cannot be written anymore.

VAR_INPUT

```
VAR_INPUT
    bExecute          : BOOL;
    oidTrafo          : UDINT;
END_VAR
```

bExecute: The command is triggered by a rising edge at this input.

oidTrafo: Object-ID of the kinematic transformation object. See [example \[► 33\]](#) below.

VAR_OUTPUT

```
VAR_OUTPUT
    bBusy             : BOOL;
    bDone             : BOOL;
    bError            : BOOL;
    nErrorId          : UDINT;
END_VAR
```

bBusy: The output becomes TRUE when the command is started with *bExecute* as long as the function block is executing the command. While *bBusy* is TRUE, no new instructions will be accepted at the inputs. When *bBusy* becomes FALSE again, the function block is ready for a new command. At the same time one of the outputs *bDone* or *bError* is set.

bDone: The output becomes true if the command succeeded.

bError: The output *bError* becomes true if an error occurs as the command is executed.

nErrorId: Contains the command-specific error code of the most recently executed command. The error code can be found in the [ADS error documentation \[► 38\]](#) or in the NC error documentation (error codes above 0x4000).

Example

Scara Transformation Example Object Id

Object	Parameter
Object Id:	0x010100B0
Object Name:	Group 9_Obj1 (SCARA)
Type Name:	SCARA
GUID:	{E7398E65-FAB9-46C9-85A8-8436924D9B13}
Class Id:	0x0501002A
Class Factory:	TcNcKin
Init Sequence:	SO

```

VAR
  bUserExecute      : BOOL;
  fbFB_LockTrafoParam : FB_LockTrafoParam;
  oidTrafo          : UDINT := 16#010100B0; (*Trafo object id*)
END_VAR

fbFB_LockTrafoParam(
  bExecute := bUserExecute,
  oidTrafo := oidTrafo,
  bBusy=>,
  bDone=>,
  bError=>,
  nErrorId=> );
    
```

5.2 Functions

5.2.1 F_GetKinChnOperationState

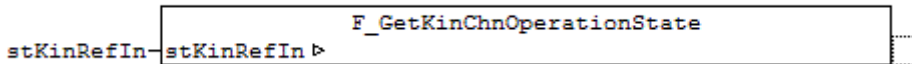

This function returns the operation state of the Kinematic Channel.

Function F_GetKinChnOperationState : E_KINSTATUS

```

VAR_IN_OUT
  stKinRefIn : NciChannelToPlc
END_VAR
    
```

stKinRefIn: Determines the configuration's kinematic group. See NciChannelToPlc

Return value

E_KINSTATUS [▶ 37]: State of the kinematics channel (cf. below). If an invalid version of cyclic interface is used, *KinStatus_InvalidItrVersion* is returned.

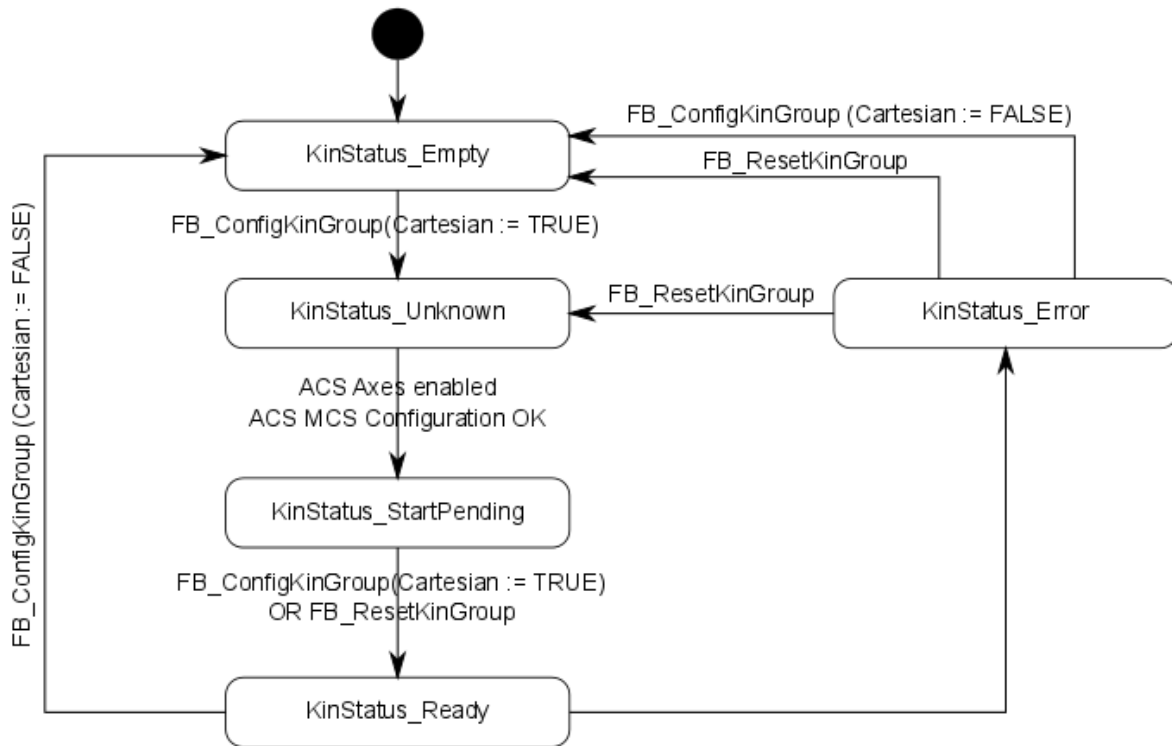

Example

```

VAR
    stKinRefIn AT %I*      : NciChannelToPlc;
    nErrId        : UDINT;
    eKinOperationState  : E_KINSTATUS;
END_VAR

IF F_GetKinChnOperationState(stKinRefIn) <> KinStatus_InvalidItfVersion THEN
    eKinOperationState := F_GetKinChnOperationState(stKinRefIn);
ELSE
    nErrId := F_GetKinChnOperationState(stKinRefIn);
END_IF
    
```

Requirements

This function is valid from version 6 of the cyclic interface. If the version is lower *KinStatus_InvalidItfVersion* (see [E_KINSTATUS](#) [▶ 37]) is returned.

5.2.2 F_GetAcsMcsAxisIds

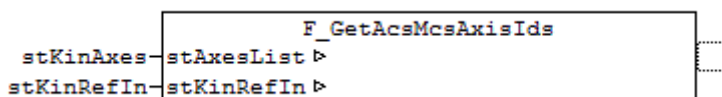

This function reads the configured ACS and MCS axes from the cyclic interface. The IDs are written into stAxesList.

FUNCTION F_GetAcsMcsAxisIds : UDINT

```

VAR_IN_OUT
    stAxesList : ST_KinAxes;
    stKinRefIn : NciChannelToPlc;
END_VAR
    
```

stAxesList: List of the Axis Ids for the Axis Coordinate System and the Machine Coordinate System

stKinRefIn: Structure of the cyclic channel interface from the Kinematic Channel to the PLC. This structure is only accessed for reading.

Return value

UDINT: Error code. This function is valid from version 6 of the cyclic interface. If the version is correct 0 is returned, otherwise an error code.

Example

```
VAR
  stAxesList      : ST_KinAxes;
  stKinRefIn AT %I* : NciChannelToPlc;
  nErrId         : UDINT;
END_VAR

nErrId := F_GetAcsMcsAxisIds(stAxesList, stKinRefIn);
IF nErrId=0 THEN
  ;(*Axes List is valid*)
END_IF
```

Requirements

This function is valid from version 6 of the cyclic interface. If the version is lower *KinStatus_InvalidIfVersion* (see [E_KINSTATUS](#) |> 371) is returned.

5.3 Datatypes

5.3.1 ST_KinAxes

This structure defines the axes, which constitute a kinematics.

```
TYPE ST_KinAxes :
STRUCT
  nAxisIdsMcs: ARRAY[1..8] OF DWORD;
  nAxisIdsAcs: ARRAY[1..8] OF DWORD;
END_STRUCT
END_TYPE
```

nAxisIdsMcs: List of the Axis Ids of the Axes constituting the Machine Coordinate System. Normally the first three array elements contain the Cartesian axes (X,Y,Z), the following array elements contain rotation axes.

nAxisIdsAcs: List of the Axis Ids of the Axes constituting the Axis Coordinate System

Example

```
VAR
  stAxesConfig      : ST_KinAxes;
  io_X              : AXIS_REF;
  io_Y              : AXIS_REF;
  io_Z              : AXIS_REF;
  io_M1             : AXIS_REF;
  io_M2             : AXIS_REF;
  io_M3             : AXIS_REF;
END_VAR

(* read the IDs from the cyclic axis interface so the axes can mapped later to the kinematic group *)
stAxesConfig.nAxisIdsAcs[1] := io_M1.NcToPlc.AxisId;
stAxesConfig.nAxisIdsAcs[2] := io_M2.NcToPlc.AxisId;
stAxesConfig.nAxisIdsAcs[3] := io_M3.NcToPlc.AxisId;
stAxesConfig.nAxisIdsMcs[1] := io_X.NcToPlc.AxisId;
stAxesConfig.nAxisIdsMcs[2] := io_Y.NcToPlc.AxisId;
stAxesConfig.nAxisIdsMcs[3] := io_Z.NcToPlc.AxisId;
```

5.3.2 E_KINSTATUS

This enumeration defines the kinematic group state.

```

TYPE E_KINSTATUS :
(
  KinStatus_Error,
  KinStatus_Empty,
  KinStatus_Unknown,
  KinStatus_StartPending,
  KinStatus_Ready,
  KinStatus_InvalidItfVersion := 16#4000
);
END_TYPE
    
```

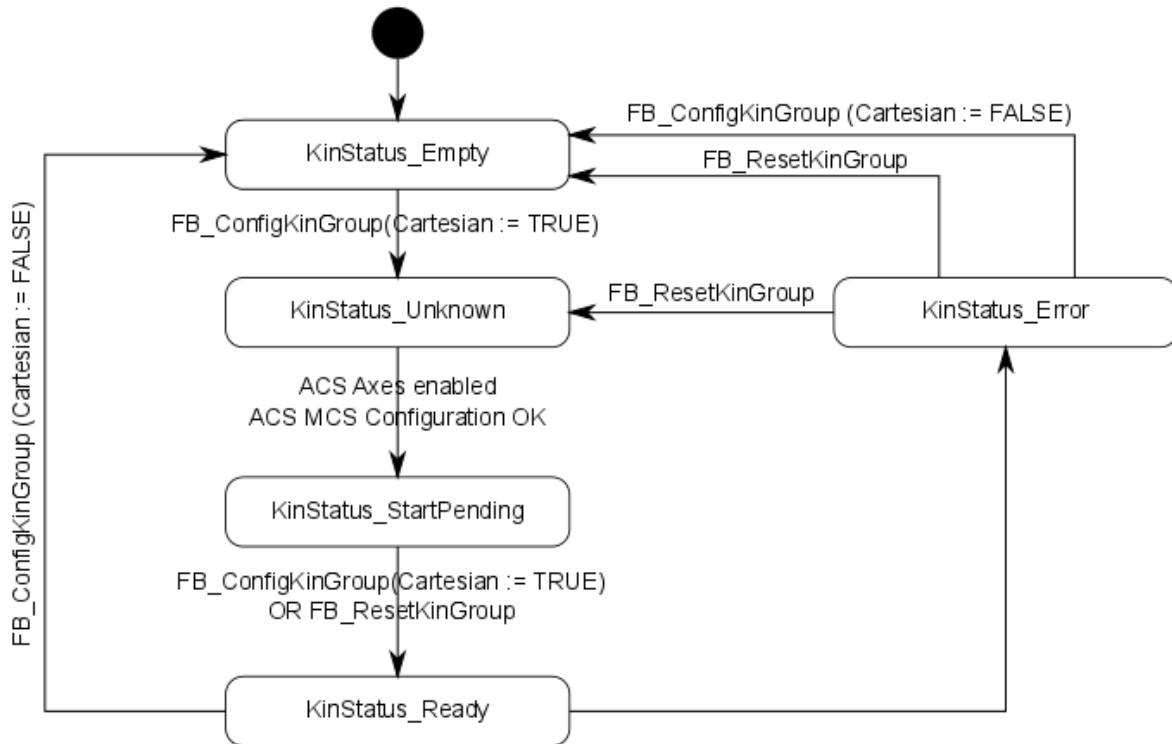

KinStatus_Empty: ACS axes can be moved. No transformation activated

KinStatus_Ready: MCS axes can be moved. Transformation active.

KinStatus_InvalidItfVersion: A Function or Function block is not supported by this version of cyclic channel interface. To use the function it is required to update



Enabling Configuration

The ACS axes must be enabled for the state to reach **KinStatus_Ready**.

6 Error Codes

6.1 ADS Return Codes

Grouping of error codes: 0x000 [▶ 38]..., 0x500 [▶ 38]..., 0x700 [▶ 39]..., 0x1000 [▶ 40]...

Global error codes

Hex	Dec	HRESULT	Name	Description
0x0	0	0x9811 0000	ERR_NOERROR	No error.
0x1	1	0x9811 0001	ERR_INTERNAL	Internal error.
0x2	2	0x9811 0002	ERR_NORTIME	No real-time.
0x3	3	0x9811 0003	ERR_ALLOCLOCKEDMEM	Allocation locked – memory error.
0x4	4	0x9811 0004	ERR_INSERTMAILBOX	Mailbox full – the ADS message could not be sent. Reducing the number of ADS messages per cycle will help.
0x5	5	0x9811 0005	ERR_WRONGRECEIVEHMSG	Wrong HMSG.
0x6	6	0x9811 0006	ERR_TARGETPORTNOTFOUND	Target port not found – ADS server is not started or is not reachable.
0x7	7	0x9811 0007	ERR_TARGETMACHINENOTFOUND	Target computer not found – AMS route was not found.
0x8	8	0x9811 0008	ERR_UNKNOWNCMDID	Unknown command ID.
0x9	9	0x9811 0009	ERR_BADTASKID	Invalid task ID.
0xA	10	0x9811 000A	ERR_NOIO	No IO.
0xB	11	0x9811 000B	ERR_UNKNOWNAMSCMD	Unknown AMS command.
0xC	12	0x9811 000C	ERR_WIN32ERROR	Win32 error.
0xD	13	0x9811 000D	ERR_PORTNOTCONNECTED	Port not connected.
0xE	14	0x9811 000E	ERR_INVALIDAMSLENGTH	Invalid AMS length.
0xF	15	0x9811 000F	ERR_INVALIDAMSNETID	Invalid AMS Net ID.
0x10	16	0x9811 0010	ERR_LOWINSTLEVEL	Installation level is too low – TwinCAT 2 license error.
0x11	17	0x9811 0011	ERR_NODEBUGINTAVAILABLE	No debugging available.
0x12	18	0x9811 0012	ERR_PORTDISABLED	Port disabled – TwinCAT system service not started.
0x13	19	0x9811 0013	ERR_PORTALREADYCONNECTED	Port already connected.
0x14	20	0x9811 0014	ERR_AMSSYNC_W32ERROR	AMS Sync Win32 error.
0x15	21	0x9811 0015	ERR_AMSSYNC_TIMEOUT	AMS Sync Timeout.
0x16	22	0x9811 0016	ERR_AMSSYNC_AMSERROR	AMS Sync error.
0x17	23	0x9811 0017	ERR_AMSSYNC_NOINDEXINMAP	No index map for AMS Sync available.
0x18	24	0x9811 0018	ERR_INVALIDAMSPORT	Invalid AMS port.
0x19	25	0x9811 0019	ERR_NOMEMORY	No memory.
0x1A	26	0x9811 001A	ERR_TCPSEND	TCP send error.
0x1B	27	0x9811 001B	ERR_HOSTUNREACHABLE	Host unreachable.
0x1C	28	0x9811 001C	ERR_INVALIDAMSFRAGMENT	Invalid AMS fragment.
0x1D	29	0x9811 001D	ERR_TLSEND	TLS send error – secure ADS connection failed.
0x1E	30	0x9811 001E	ERR_ACCESSDENIED	Access denied – secure ADS access denied.

Router error codes

Hex	Dec	HRESULT	Name	Description
0x500	1280	0x9811 0500	ROUTERERR_NOLOCKEDMEMORY	Locked memory cannot be allocated.
0x501	1281	0x9811 0501	ROUTERERR_RESIZEMEMORY	The router memory size could not be changed.
0x502	1282	0x9811 0502	ROUTERERR_MAILBOXFULL	The mailbox has reached the maximum number of possible messages.
0x503	1283	0x9811 0503	ROUTERERR_DEBUGBOXFULL	The Debug mailbox has reached the maximum number of possible messages.
0x504	1284	0x9811 0504	ROUTERERR_UNKNOWNPORTTYPE	The port type is unknown.

Hex	Dec	HRESULT	Name	Description
0x505	1285	0x9811 0505	ROUTERERR_NOTINITIALIZED	The router is not initialized.
0x506	1286	0x9811 0506	ROUTERERR_PORTALREADYINUSE	The port number is already assigned.
0x507	1287	0x9811 0507	ROUTERERR_NOTREGISTERED	The port is not registered.
0x508	1288	0x9811 0508	ROUTERERR_NOMOREQUEUES	The maximum number of ports has been reached.
0x509	1289	0x9811 0509	ROUTERERR_INVALIDPORT	The port is invalid.
0x50A	1290	0x9811 050A	ROUTERERR_NOTACTIVATED	The router is not active.
0x50B	1291	0x9811 050B	ROUTERERR_FRAGMENTBOXFULL	The mailbox has reached the maximum number for fragmented messages.
0x50C	1292	0x9811 050C	ROUTERERR_FRAGMENTTIMEOUT	A fragment timeout has occurred.
0x50D	1293	0x9811 050D	ROUTERERR_TOBEREMOVED	The port is removed.

General ADS error codes

Hex	Dec	HRESULT	Name	Description
0x700	1792	0x9811 0700	ADSERR_DEVICE_ERROR	General device error.
0x701	1793	0x9811 0701	ADSERR_DEVICE_SRVNOTSUPP	Service is not supported by the server.
0x702	1794	0x9811 0702	ADSERR_DEVICE_INVALIDGRP	Invalid index group.
0x703	1795	0x9811 0703	ADSERR_DEVICE_INVALIDOFFSET	Invalid index offset.
0x704	1796	0x9811 0704	ADSERR_DEVICE_INVALIDACCESS	Reading or writing not permitted.
0x705	1797	0x9811 0705	ADSERR_DEVICE_INVALIDSIZE	Parameter size not correct.
0x706	1798	0x9811 0706	ADSERR_DEVICE_INVALIDDATA	Invalid data values.
0x707	1799	0x9811 0707	ADSERR_DEVICE_NOTREADY	Device is not ready to operate.
0x708	1800	0x9811 0708	ADSERR_DEVICE_BUSY	Device is busy.
0x709	1801	0x9811 0709	ADSERR_DEVICE_INVALIDCONTEXT	Invalid operating system context. This can result from use of ADS function blocks in different tasks. It may be possible to resolve this through Multi-task data access synchronization in the PLC.
0x70A	1802	0x9811 070A	ADSERR_DEVICE_NOMEMORY	Insufficient memory.
0x70B	1803	0x9811 070B	ADSERR_DEVICE_INVALIDPARM	Invalid parameter values.
0x70C	1804	0x9811 070C	ADSERR_DEVICE_NOTFOUND	Not found (files, ...).
0x70D	1805	0x9811 070D	ADSERR_DEVICE_SYNTAX	Syntax error in file or command.
0x70E	1806	0x9811 070E	ADSERR_DEVICE_INCOMPATIBLE	Objects do not match.
0x70F	1807	0x9811 070F	ADSERR_DEVICE_EXISTS	Object already exists.
0x710	1808	0x9811 0710	ADSERR_DEVICE_SYMBOLNOTFOUND	Symbol not found.
0x711	1809	0x9811 0711	ADSERR_DEVICE_SYMBOLVERSIONINVALID	Invalid symbol version. This can occur due to an on-line change. Create a new handle.
0x712	1810	0x9811 0712	ADSERR_DEVICE_INVALIDSTATE	Device (server) is in invalid state.
0x713	1811	0x9811 0713	ADSERR_DEVICE_TRANSMODENOTSUPP	AdsTransMode not supported.
0x714	1812	0x9811 0714	ADSERR_DEVICE_NOTIFYHNDINVALID	Notification handle is invalid.
0x715	1813	0x9811 0715	ADSERR_DEVICE_CLIENTUNKNOWN	Notification client not registered.
0x716	1814	0x9811 0716	ADSERR_DEVICE_NOMOREHDLS	No further handle available.
0x717	1815	0x9811 0717	ADSERR_DEVICE_INVALIDWATCHSIZE	Notification size too large.
0x718	1816	0x9811 0718	ADSERR_DEVICE_NOTINIT	Device not initialized.
0x719	1817	0x9811 0719	ADSERR_DEVICE_TIMEOUT	Device has a timeout.
0x71A	1818	0x9811 071A	ADSERR_DEVICE_NOINTERFACE	Interface query failed.
0x71B	1819	0x9811 071B	ADSERR_DEVICE_INVALIDINTERFACE	Wrong interface requested.
0x71C	1820	0x9811 071C	ADSERR_DEVICE_INVALIDCLSID	Class ID is invalid.
0x71D	1821	0x9811 071D	ADSERR_DEVICE_INVALIDOBJID	Object ID is invalid.
0x71E	1822	0x9811 071E	ADSERR_DEVICE_PENDING	Request pending.
0x71F	1823	0x9811 071F	ADSERR_DEVICE_ABORTED	Request is aborted.
0x720	1824	0x9811 0720	ADSERR_DEVICE_WARNING	Signal warning.
0x721	1825	0x9811 0721	ADSERR_DEVICE_INVALIDARRAYIDX	Invalid array index.
0x722	1826	0x9811 0722	ADSERR_DEVICE_SYMBOLNOTACTIVE	Symbol not active.
0x723	1827	0x9811 0723	ADSERR_DEVICE_ACCESSDENIED	Access denied.
0x724	1828	0x9811 0724	ADSERR_DEVICE_LICENSENOTFOUND	Missing license.
0x725	1829	0x9811 0725	ADSERR_DEVICE_LICENSEEXPIRED	License expired.
0x726	1830	0x9811 0726	ADSERR_DEVICE_LICENSEEXCEEDED	License exceeded.
0x727	1831	0x9811 0727	ADSERR_DEVICE_LICENSEINVALID	Invalid license.
0x728	1832	0x9811 0728	ADSERR_DEVICE_LICENSESYSTEMID	License problem: System ID is invalid.
0x729	1833	0x9811 0729	ADSERR_DEVICE_LICENSENOTTIMELIMIT	License not limited in time.

Hex	Dec	HRESULT	Name	Description
0x72A	1834	0x9811 072A	ADSERR_DEVICE_LICENSEFUTUREISSUE	License problem: Time in the future.
0x72B	1835	0x9811 072B	ADSERR_DEVICE_LICENSETIMETOLONG	License period too long.
0x72C	1836	0x9811 072C	ADSERR_DEVICE_EXCEPTION	Exception at system startup.
0x72D	1837	0x9811 072D	ADSERR_DEVICE_LICENSEDUPLICATED	License file read twice.
0x72E	1838	0x9811 072E	ADSERR_DEVICE_SIGNATUREINVALID	Invalid signature.
0x72F	1839	0x9811 072F	ADSERR_DEVICE_CERTIFICATEINVALID	Invalid certificate.
0x730	1840	0x9811 0730	ADSERR_DEVICE_LICENSEOEMNOT- FOUND	Public key not known from OEM.
0x731	1841	0x9811 0731	ADSERR_DEVICE_LICENSERESTRICTED	License not valid for this system ID.
0x732	1842	0x9811 0732	ADSERR_DEVICE_LICENSEDEMOMDENIED	Demo license prohibited.
0x733	1843	0x9811 0733	ADSERR_DEVICE_INVALIDDFNCID	Invalid function ID.
0x734	1844	0x9811 0734	ADSERR_DEVICE_OUTOFRANGE	Outside the valid range.
0x735	1845	0x9811 0735	ADSERR_DEVICE_INVALIDALIGNMENT	Invalid alignment.
0x736	1846	0x9811 0736	ADSERR_DEVICE_LICENSEPLATFORM	Invalid platform level.
0x737	1847	0x9811 0737	ADSERR_DEVICE_FORWARD_PL	Context – forward to passive level.
0x738	1848	0x9811 0738	ADSERR_DEVICE_FORWARD_DL	Context – forward to dispatch level.
0x739	1849	0x9811 0739	ADSERR_DEVICE_FORWARD_RT	Context – forward to real-time.
0x740	1856	0x9811 0740	ADSERR_CLIENT_ERROR	Client error.
0x741	1857	0x9811 0741	ADSERR_CLIENT_INVALIDPARG	Service contains an invalid parameter.
0x742	1858	0x9811 0742	ADSERR_CLIENT_LISTEMPTY	Polling list is empty.
0x743	1859	0x9811 0743	ADSERR_CLIENT_VARUSED	Var connection already in use.
0x744	1860	0x9811 0744	ADSERR_CLIENT_DUPLINVOKEID	The called ID is already in use.
0x745	1861	0x9811 0745	ADSERR_CLIENT_SYNCTIMEOUT	Timeout has occurred – the remote terminal is not responding in the specified ADS timeout. The route setting of the remote terminal may be configured incorrectly.
0x746	1862	0x9811 0746	ADSERR_CLIENT_W32ERROR	Error in Win32 subsystem.
0x747	1863	0x9811 0747	ADSERR_CLIENT_TIMEOUTINVALID	Invalid client timeout value.
0x748	1864	0x9811 0748	ADSERR_CLIENT_PORTNOTOPEN	Port not open.
0x749	1865	0x9811 0749	ADSERR_CLIENT_NOAMSADDR	No AMS address.
0x750	1872	0x9811 0750	ADSERR_CLIENT_SYNCINTERNAL	Internal error in Ads sync.
0x751	1873	0x9811 0751	ADSERR_CLIENT_ADDHASH	Hash table overflow.
0x752	1874	0x9811 0752	ADSERR_CLIENT_REMOVEHASH	Key not found in the table.
0x753	1875	0x9811 0753	ADSERR_CLIENT_NOMORESVM	No symbols in the cache.
0x754	1876	0x9811 0754	ADSERR_CLIENT_SYNCRESINVALID	Invalid response received.
0x755	1877	0x9811 0755	ADSERR_CLIENT_SYNCPORTLOCKED	Sync Port is locked.

RTime error codes

Hex	Dec	HRESULT	Name	Description
0x1000	4096	0x9811 1000	RTERR_INTERNAL	Internal error in the real-time system.
0x1001	4097	0x9811 1001	RTERR_BADTIMERPERIODS	Timer value is not valid.
0x1002	4098	0x9811 1002	RTERR_INVALIDTASKPTR	Task pointer has the invalid value 0 (zero).
0x1003	4099	0x9811 1003	RTERR_INVALIDSTACKPTR	Stack pointer has the invalid value 0 (zero).
0x1004	4100	0x9811 1004	RTERR_PRIOEXISTS	The request task priority is already assigned.
0x1005	4101	0x9811 1005	RTERR_NOMORETCB	No free TCB (Task Control Block) available. The maximum number of TCBs is 64.
0x1006	4102	0x9811 1006	RTERR_NOMORESEMAS	No free semaphores available. The maximum number of semaphores is 64.
0x1007	4103	0x9811 1007	RTERR_NOMOREQUEUES	No free space available in the queue. The maximum number of positions in the queue is 64.
0x100D	4109	0x9811 100D	RTERR_EXTIRQALREADYDEF	An external synchronization interrupt is already applied.
0x100E	4110	0x9811 100E	RTERR_EXTIRQNOTDEF	No external sync interrupt applied.
0x100F	4111	0x9811 100F	RTERR_EXTIRQINSTALLFAILED	Application of the external synchronization interrupt has failed.
0x1010	4112	0x9811 1010	RTERR_IRQNOTLESSOREQUAL	Call of a service function in the wrong context
0x1017	4119	0x9811 1017	RTERR_VMXNOTSUPPORTED	Intel VT-x extension is not supported.
0x1018	4120	0x9811 1018	RTERR_VMXDISABLED	Intel VT-x extension is not enabled in the BIOS.
0x1019	4121	0x9811 1019	RTERR_VMXCONTROLSMISSING	Missing function in Intel VT-x extension.

Hex	Dec	HRESULT	Name	Description
0x101A	4122	0x9811 101A	RTERR_VMXENABLEFAILS	Activation of Intel VT-x fails.

TCP Winsock error codes

Hex	Dec	Name	Description
0x274C	10060	WSAETIMEDOUT	A connection timeout has occurred - error while establishing the connection, because the remote terminal did not respond properly after a certain period of time, or the established connection could not be maintained because the connected host did not respond.
0x274D	10061	WSAECONNREFUSED	Connection refused - no connection could be established because the target computer has explicitly rejected it. This error usually results from an attempt to connect to a service that is inactive on the external host, that is, a service for which no server application is running.
0x2751	10065	WSAEHOSTUNREACH	No route to host - a socket operation referred to an unavailable host.

More Winsock error codes: Win32 error codes

6.2 Overview of NC Errors

Error code (hex)	Description
0x4000 - 0x4FFF: NC error code range	
0x40nn	General errors [▶ 41]
0x41nn	Channel Errors [▶ 43]
0x42nn	Group Errors [▶ 46]
0x43nn	Axis Errors [▶ 65]
0x44nn	Encoder Errors [▶ 72]
0x45nn	Controller Errors [▶ 77]
0x46nn	Drive Errors [▶ 81]
0x4Ann	Table Errors [▶ 87]
0x4Bnn	NC PLC errors [▶ 89]
0x4Cnn	Kinematic Transformation [▶ 94]
0x8000 ... 0x8FFF: New extended NC error code range	
0x81nn - 0x811F	Bode plot (diagnosis) [▶ 95]
0x8120 - 0x8FFF	further errors [▶ 97]

6.2.1 General NC Errors

Error(Hex)	Error(Dec)	Error Type	Description
4000	16384	Internal	"Internal error" Internal system error in the NC on ring 0, no further details.
4001	16385	Memory	"Memory error" The ring-0 memory management is not providing the required memory. This is usually a result of another error, as a result of which the controller will halt normal operation (now if not before).
4002	16386	Internal	"Nc retain data error (persistent data)" Error while loading the Nc retain data. The axes concerned are no longer referenced (status flag "Homed" is set to FALSE). Possible reasons are: - Nc retain data not found - Nc retain data expired (old backup data) - Nc retain data corrupt or inconsistent
4003	16387	Parameter	Parameter for Monitoring the NC Setpoint Issuing is Invalid

Error(Hex)	Error(Dec)	Error Type	Description
			The parameter for activating or deactivating the function "cyclic monitoring of NC setpoint issuing on continuity and consistency" is invalid. (Special function.)
4004	16388	Internal	External Error This error code can be set by an external module (e.g. third-party module) or can be set when an external module exhibits an error.
4010	16400	Parameter	"Channel identifier not allowed" Either an unacceptable value (not 1...255) has been used, or a channel that does not exist in the system has been named.
4011	16401	Parameter	"Group identifier not allowed" Either an unacceptable value (not 1...255) has been used, or a group that does not exist in the system has been named.
4012	16402	Parameter	"Axis identifier not allowed" Either an unacceptable value (not 1...255) has been used, or an axis that does not exist in the system has been named.
4013	16403	Parameter	"Encoder identifier not allowed" Either an unacceptable value (not 1...255) has been used, or an encoder that does not exist in the system has been named.
4014	16404	Parameter	"Controller identifier not allowed" Either an unacceptable value (not 1...255) has been used, or a controller that does not exist in the system has been named.
4015	16405	Parameter	"Drive identifier not allowed" Either an unacceptable value (not 1...255) has been used, or a drive that does not exist in the system has been named.
4016	16406	Parameter	"Table identifier not allowed" Either an unacceptable value (not 1...255) has been used, or a table that does not exist in the system has been named.
4020	16416	Internal	"No process image" No PLC-axis interface during creation of an axis.
4021	16417	Internal	"No process image" No axis-PLC interface during creation of an axis.
4022	16418	Internal	"No process image" No encoder-I/O interface during creation of an axis.
4023	16419	Internal	"No process image" No I/O-encoder interface during creation of an axis.
4024	16420	Internal	"No process image" No drive-I/O interface during creation of an axis.
4025	16421	Internal	"No process image" No I/O-drive interface during creation of an axis.
4030	16432	Internal	"Coupling type not allowed" Unacceptable master/slave coupling type.
4031	16433	Internal	"Axis type not allowed" Unacceptable type specification during creation of an axis.
4032	16434	Parameter	Unknown Channel Type The NC channel type is unknown. Known types are e.g. an NCI channel, a FIFO channel, etc..
4040	16448	Internal	"Axis is incompatible" Axis is not suitable for the intended purpose. A high speed/low speed axis, for example, cannot function as a slave in an axis coupling.

Error(Hex)	Error(Dec)	Error Type	Description
4050	16464	Internal	"Channel not ready for operation" The channel is not complete, and is therefore not ready for operation. This is usually a consequence of problems at system start-up.
4051	16465	Internal	"Group not ready for operation" The group is not complete, and is therefore not ready for operation. This is usually a consequence of problems at system start-up.
4052	16466	Internal	"Axis not ready for operation" The axis is not complete, and is therefore not ready for operation. This is usually a consequence of problems at system start-up.
4060	16480	Internal	"Channel exists" The channel that is to be created already exists.
4061	16481	Internal	"Group exists" The group that is to be created already exists.
4062	16482	Internal	"Axis exists" The axis that is to be created already exists.
4063	16483	Internal	"Table exists" The table that is to be created already exists, resp. it is tried internally to use an already existing table id (e.g. for the universal flying saw).
4070	16496	Internal	"Axis index not allowed" The location within the channel specified for an axis is not allowed.
4071	16497	Internal	"Axis index not allowed" The location within the group specified for an axis is not allowed.

6.2.2 Channel Errors

Error(Hex)	Error(Dec)	Error Type	Description
4101	16641	Parameter	"Group index not allowed" The location within the channel specified for a group is not allowed.
4102	16642	Address	"Null pointer" The pointer to the group is invalid. This is usually a consequence of an error at system start-up.
4103	16643	Internal	"No process image" It is not possible to exchange data with the PLC. Possible causes: n the channel does not have an interface (no interpreter present) n The connection to the PLC is faulty
4104	16644	Parameter	"M-function index not allowed" Unacceptable M-function (not 0...159) detected at the execution level.
4105	16645	Memory	"No memory" No more system memory is available. This is usually the result of another error.
4106	16646	Function	"Not ready" The function is not presently available, because a similar function is already being processed. This is usually the result of access conflicts: more than one instance wants to issue commands to the channel. This can, for example, be the consequence of an incorrect PLC program.
4107	16647	Function	"Function/command not supported" A requested function or command is not supported by the channel.

Error(Hex)	Error(Dec)	Error Type	Description
4108	16648	Parameter	"Invalid parameter while starting" Parameters to start the channel (TwinCAT-Start) are invalid. Typically there is an invalid memory size or channel type requested.
4109	16649	Function	"Channel function/command not executable" A channel function e.g. interpreter start is not executable because the channel is already busy, no program is loaded or in an error state.
410A	16650	Function	"ItpGoAhead not executable" The requested command is not executable, because the interpreter is not executing a decoder stop.
4110	16656	Parameter	"Error opening a file" The specified file does not exist. Sample: NC program unknown.
4111	16657	NC Programming	"Syntax error during loading" The NC has found a syntax error when loading an NC program.
4112	16658	NC Programming	"Syntax error during interpretation" The NC has found a syntax error when executing an NC program.
4113	16659	NC Programming	"Missing subroutine" The NC has found a missing subroutine while loading.
4114	16660	Memory	"Loading buffer of interpreter is too small" The capacity of the interpreter loading buffer has been exceeded.
4115	16661	Internal	"Symbolic" - reserved
4116	16662	Internal	"Symbolic" - reserved
4117	16663	NC Programming	"Subroutine incomplete" Header of subroutine is missing
4118	16664	NC Programming	"Error while loading the NC program" The maximum number of loadable NC programs has been reached. Possible cause: Too many sub-programs were loaded from a main program.
4119	16665	NC Programming	"Error while loading the NC program" The program name is too long.
4120	16672	NC Programming	"Divide by zero" The NC encountered a computation error during execution: division by 0.
4121	16673	NC Programming	"Invalid circle parameterization" The NC encountered a computation error during execution: The specified circle cannot be calculated.
4122	16674	NC Programming	"Invalid FPU-Operation" The NC encountered an invalid FPU-Operation during execution. This error occurs e.g. by calculating the square root of a negative number.
4130	16688	NC Programming	"Stack overflow: subroutines" The NC encountered a stack overflow during execution: too many subroutine levels.
4131	16689	NC Programming	"Stack underflow: subroutines" The NC encountered a stack underflow during execution: too many subroutine return commands. Note: A main program must not end with a return command.
4132	16690	NC Programming	"Stack overflow: arithmetic unit" The NC encountered a stack overflow during execution: The calculation is too complex, or has not been correctly written.

Error(Hex)	Error(Dec)	Error Type	Description
4133	16691	NC Programming	"Stack underflow: arithmetic unit" The NC encountered a stack underflow during execution: The calculation is too complex, or has not been correctly written.
4140	16704	Parameter	"Register index not allowed" The NC encountered an unacceptable register index during execution: Either the program contains an unacceptable value (not R0...R999) or a pointer register contains an unacceptable value.
4141	16705	NC Programming	"Unacceptable G-function index" The NC has encountered an unacceptable G-function (not 0...159) during execution.
4142	16706	NC Programming	"Unacceptable M-function index" The NC has encountered an unacceptable M-function (not 0...159) during execution.
4143	16707	NC Programming	"Unacceptable extended address" The NC has encountered an unacceptable extended address (not 1...9) during execution.
4144	16708	NC Programming	"Unacceptable index to the internal H-function" The NC has encountered an unacceptable internal H-function in the course of processing. This is usually a consequence of an error during loading.
4145	16709	Parameter	"Machine data value unacceptable" While processing instructions the NC has detected an impermissible value for the machine data (MDB) (not 0...7).
4150	16720	Parameter	"Cannot change tool params here" The NC has encountered an unacceptable change of parameters for the tool compensation during execution. This error occurred for instance by changing the tool radius and programming a circle in the same block.
4151	16721	Parameter	"Cannot calculate tool compensation" The NC has encountered an error by the calculation of the tool compensation.
4152	16722	NC Programming	Tool compensation: The plane for the tool compensation cannot be changed here. This error occurred for instance by changing the tool plane when the compensation is turned on or active.
4153	16723	NC Programming	Tool compensation: The D-Word is missing or invalid by turning on the tool compensation.
4154	16724	NC Programming	Tool compensation: The specified tool radius is invalid because the value is less or equal zero.
4155	16725	NC Programming	Tool compensation: The tool radius cannot be changed here
4156	16726	Internal	Tool compensation: Collision Detection Table is full.
4157	16727	Internal	Tool compensation: Internal error while turning on the contour collision detection.
4158	16728	Internal	Tool compensation: Internal error within the contour collision detection: update reversed geo failed.
4159	16729	NC Programming	Tool compensation: Unexpected combination of geometry types by active contour collision detection.
415A	16730	NC Programming	Tool compensation: Programmed inner circle is smaller than the cutter radius

Error(Hex)	Error(Dec)	Error Type	Description
415B	16731	NC Programming	Tool compensation: Bottle neck detection recognized contour violation
415C	16732	Memory	Table for corrected entries is full
415D	16733	Memory	Input table for tangential following is full
415E	16734	Memory	Executing table for tangential following is full
415F	16735	Internal	Geometric entry for tangential following cannot be calculated
4160	16736	Internal	reserved
4161	16737	Internal	reserved
4162	16738	Parameter	The actual active interpolation rules (g-code), zero-shifts, or rotation cannot be detected
4170	16752	NC Programming	"Error while loading: Invalid parameter" The NC has found an invalid parameter while loading an NC program.
4171	16753	Internal	"Invalid contour start position" The NC encountered a computation error during execution: The specified contour cannot be calculated because the initial position is not on the contour.
4172	16754	Internal	"Retrace: Invalid internal entry index" The NC encountered an invalid internal entry index during execution of the retrace function.
4173	16755	NC Programming	Invalid G Code Invalid default G Code. False expression/syntax in default G Code.
4174	16756	NC Programming	Error while Opening the G Code File Error while opening the default G code file.

6.2.3 Group Errors

Error(Hex)	Error(Dec)	Error Type	Description
4200	16896	Parameter	"Group ID not allowed" The value for the group ID is not allowed, e.g. because it has already been assigned, is less than or equal to zero, or is greater than 255. Value range: [1 ... 255] Unit: 1
4201	16897	Parameter	"Group type not allowed" The value for the group type is unacceptable because it is not defined. Type 1: PTP group with slaves (servo) Type 4: DXD group with slaves (3D group) Type 5: High/low speed group Type 6: Stepper motor group Type 9: Encoder group with slaves (servo) ... Value range: [1 ... 12] Unit: 1
4202	16898	Initialization	"Master axis index not allowed" The value for the master axis index in an interpolating 3D group is not allowed, because, for instance, it has gone outside the value range. Index 0: X axis (first master axis) Index 1: Y axis (second master axis) Index 2 : Z axis (third master axis) Value range: [0, 1, 2] Unit: 1
4203	16899	Initialization	"Slave axis index not allowed" (INTERNAL ERROR) The value for the slave axis index in a group is not allowed, because, for instance, it has passed outside the value

Error(Hex)	Error(Dec)	Error Type	Description
			range, the slave location to be used when inserting a new slave connection is already occupied, or because no slave is present when such a connection is being removed. Index 0: First slave axis Index 1: Second slave axis Index 2: etc. Value range: [0 ... 7] Unit: 1
4204	16900	Initialization	Internal Error A nonexpected internal error has occurred. The following situations may have caused this effect: There is not enough TC router memory or Windows memory to establish the internal NC objects, internal NC structures and links (pointers between NC objects) are erroneous or are missing, a fatal internal error in calculating a stop command or a halt command has occurred, internal checking of NC own logic and algorithms (self-checking software), nonexpected modes and cases that are not intended regularly, but are recognized being erroneous. Note: Quite often in such an error situation an additional error message in the Windows event logger is thrown that can be helpful for a more detailed analysis by Beckhoff or by the user.
4205	16901	Parameter	"Invalid cycle time for statement execution task (SAF)" The value of the cycle time for the NC block execution task (SAF 1/2) is not allowed, because it has passed outside the value range. Value range: [0.001 ... 0.1] Unit: s
4206	16902	Initialization	"GROUPERR_RANGE_MAXELEMENTSINAXIS "
4207	16903	Parameter	"Invalid cycle time for the statement preparation task (SVB)" The value of the cycle time for the NC statement preparation task (SVB 1/2) is not allowed, because it has passed outside the value range. Value range: [0.001 ... 1.0] Unit: s
4208	16904	Parameter	"Single step mode not allowed" The flag for the activation or deactivation of single step mode is not allowed. Value 0: Passive (buffered operation) Value 1: Active (single-block operation) Value range: [0, 1] Unit: 1
4209	16905	Parameter	"Group deactivation not allowed" (INTERNAL ERROR) The flag for the deactivation or activation of the complete group is not allowed. Value 0: Group active Value 1: Group passive Value range: [0, 1] Unit: 1
420A	16906	Initialization	"Statement execution state (SAF state) not allowed" (INTERNAL ERROR) The value for the state of the block execution state machine (SAF state) is not allowed. This error occurs on passing outside the range of values, or if the state machine enters an error state. Value range: [0 ... 5] Unit: 1
420B	16907	Address	"Channel address" The group does not have a channel, or the channel address has not been initialized.
420C	16908	Address	"Axis address (master axis)" The group does not have a master axis (or axes) or the axis address(es) has (have) not been initialized.

Error(Hex)	Error(Dec)	Error Type	Description
420D	16909	Address	"Master axis address" A new master/slave coupling is to be inserted into the group, but there is no valid address for the leading master axis.
420E	16910	Address	"Slave axis address" A master/slave coupling is to be inserted into the group, but there is no valid address for the slave axis.
420F	16911	Address	"Slave set value generator address" A master/slave coupling is to be inserted into the group, but there is no valid address for the slave set value generator.
4210	16912	Address	"Encoder address" An axis in the group does not have an encoder, or the encoder address has not been initialized.
4211	16913	Address	"Controller address" An axis in the group does not have a controller, or the controller address has not been initialized.
4212	16914	Address	"Drive address" An axis in the group does not have a drive, or the drive address has not been initialized.
4213	16915	Address	Address Master Setpoint Generator A group (e.g. FIFO group) does not own a master setpoint generator or a setpoint generator address has not been initialized. Possibly, there may not be enough memory available.
4214	16916	Address	"Axis interface NC to PLC address" Group/axis does not have an axis interface from the NC to the PLC, or the axis interface address has not been initialized.
4215	16917	Address	"Slave axis address" An existing master/slave coupling is to be removed from the group, but there is no valid address for the slave axis.
4216	16918	Address	"Table address unknown" The table, respectively the table ID, is unknown. This table is used for the master/slave coupling or for the characteristic curve.
4217	16919	Address	"NcControl address" The NcControl address has not been initialized.
4218	16920	Initialization	"Axis is blocked for commands while persistent NC data are queued" Axis is blocked for commands while waiting for valid IO data to accept the queued persistent NC data.
4219	16921	Function	"The scaling mode MASTER-AUTOOFFSET is invalid because no reference table was found" . The used scaling mode MASTER-AUTOOFFSET is invalid in this context because an existing reference table is missing. This error can occur for example when adding cam tables without a unique reference to an existing cam table.
421A	16922	Parameter	"The master axis start position does not permit synchronization" When a slave axis is being coupled on, the position of the master axis does not permit synchronization at the given synchronization positions.
421B	16923	Parameter	"Slave coupling factor (gearing factor) of 0.0 is not allowed" A master/slave coupling with a gearing factor of 0.0 is being created. This value is not allowed, since it does not correspond to any possible coupling, and division will generate an FPU exception.
421C	16924	Function	"Insertion of master axis into group not allowed" A master axis is to be inserted into a group at a location that is already occupied by another master axis. Maybe the reconfiguration cannot be done, because this axis has got an existing slave coupling. This master/slave coupling must be revoked before.

Error(Hex)	Error(Dec)	Error Type	Description
421D	16925	Function	"Deletion of master axis from group not allowed" (INTERNAL ERROR) A master axis is to be removed from a location in a group that is not in fact occupied by master axis.
421E	16926	Function	"Function/feature is not supported from the setpoint generator" A function or feature is not supported from the setpoint generator (e.g. PTP master setpoint generator). This can be in general or only in a special situation.
421F	16927	Initialization	"Group initialization" Group has not been initialized. Although the group has been created, the rest of the initialization has not been performed (1. Initialization of group I/O, 2. Initialization of group, 3. Reset group).
4220	16928	Monitoring	"Group not ready / group not ready for new task" The group is being given a new task while it is still in the process of executing an existing task. This request is not allowed because it would interrupt the execution of the previous task. The new task could, for instance, be a positioning command, or the "set actual position" function. Precisely the converse relationships apply for the "set new end position" function. In that case, the group/axis must still be actively moving in order to be able to cause a change in the end position.
4221	16929	Monitoring	"Requested set velocity is not allowed" The value requested for the set velocity of a positioning task is less than or equal to zero, larger than the "maximum velocity" (see axis parameters), or, in the case of servo-drives, is larger than the "reference velocity" of the axis (see drive parameters).
4222	16930	Monitoring	"Requested target position is not allowed (master axis)" The requested value for the target position of a positioning task is not within the software end locations. In other words, it is either less than the minimum software end location or larger than the maximum software end location. This check is only carried out if the relevant end position monitoring is active.
4223	16931	Monitoring	"No enable for controller and/or feed (Master axis)" The axis enables for the master axis needed for positioning are not present. This can involve the controller enable and/or the relevant, direction-dependent feed enable (see axis interface PlcToNc).
4224	16932	Monitoring	"Movement smaller than one encoder increment" (INTERNAL ERROR) The distance that a group/axis is supposed to move is smaller than the physical significance of one encoder increment. In other words the movement is smaller than the scaling factor of the axis. The reaction to this is that the axis is reported as having logically finished without having actively moved. This means that an external error is not generated for the user. This error is also issued for high/low speed axes if a loop movement with nonzero parameters is smaller than the sum of the creeping and braking distances. In such a case it is not meaningful to either exceed or to fail to reach the target position.
4225	16933	Monitoring	"Drive not ready during axis start" During an axis start it is ascertained that the drive is not ready. The following are possible causes: - the drive is in the error state (hardware error) - the drive is in the start-up phase (e.g. after an axis reset that was preceded by a hardware error) - the drive is

Error(Hex)	Error(Dec)	Error Type	Description
			missing the controller enable (ENABLE) Note: The time required for "booting" a drive after a hardware fault can amount to several seconds.
4226	16934	Monitoring	"Invalid parameters of the emergency stop." Either, both, the deceleration and the jerk are less than zero or one of the parameters is weaker than the corresponding parameter of the start data.
4227	16935	Function	"The setpoint generator is inactive such that no instructions are accepted."
4228	16936	Monitoring	"Requested traverse distance is not allowed" The requested traverse distance or looping distance is smaller than the braking distance of the two/speed axis.
4229	16937	Monitoring	"Requested target position is not allowed (slave axis)" The value for the target position of a positioning task when calculated for the slave axis is not within the software end locations. In other words, it is either less than the minimum software end location or larger than the maximum software end location. This check is only carried out if the relevant end position monitoring is active.
422A	16938	Monitoring	"No enable for controller and/or feed (slave axis)" The axis enables for one or more coupled slave axes needed for positioning are not present. This can involve the controller enable and/or the relevant, direction-dependent feed enable (see axis interface PlcToNc).
422B	16939	Parameter	"The activation position (position threshold) is out of range of the actual positioning" The activation position (position threshold) of a new axis command (e.g. "new velocity activated at a position") is out of range. E.g. the activation position is before the actual position or behind the target position.
422C	16940	Parameter	"The start or activation data of the external setpoint generation are not valid" This may be caused through: 1. The external setpoint generation is active and a new activation with a start type (1: absolute, 2: relative) unequal to the current one is send. 2. The internal setpoint generation is active (e.g. PTP) and the external one is activated with the type absolute (two setpoint generators of the type absolute are not possible).
422D	16941	Parameter	"Velocity is not constant" For changing the dynamic parameter 'acceleration' und 'deceleration' the axis has to be in dynamic state without acceleration and deceleration (that means constant velocity).
422E	16942	Parameter	"Jerk less than or equal to 0.0 is not allowed" A value less than or equal to 0.0 for the jerk (PTP and CNC) is not allowed, since the jerk is by definition positive, and with a jerk of 0.0, division will generate an FPU exception.
422F	16943	Parameter	"Acceleration less than or equal to 0.0 is not allowed" A value less than or equal to 0.0 for the acceleration (PTP and CNC) is not allowed, since the acceleration is positive by definition, and an acceleration of 0.0 will not allow a motion to be generated.
4230	16944	Parameter	"Absolute deceleration value less than or equal to 0.0 is not allowed" A value less than or equal to 0.0 for the absolute value of the deceleration (PTP and CNC) is not allowed, since the absolute value of the deceleration is positive by definition, and an absolute value of the deceleration of 0.0 will not allow a motion to be generated.

Error(Hex)	Error(Dec)	Error Type	Description
4231	16945	Parameter	"Set velocity less than or equal to 0.0 is not allowed" A value less than or equal to 0.0 or outside the range from 10^{-3} up to 10^{+10} for the set velocity (PTP and CNC) is not allowed, since the set velocity is by definition strictly positive, and with a set velocity of 0.0, division will generate an FPU exception.
4232	16946	Monitoring	"Loss of precision when trying a positioning" The positioning is so long in space or time that decimal parts lose their relevance (LOSS_OF_PRECISION).
4233	16947	Parameter	"Cycle time less than or equal to 0.0 is not allowed" A value less than or equal to 0.0 for the cycle time (PTP and CNC) is not allowed, since the cycle time is by definition strictly positive, and with a cycle time of 0.0, division will generate an FPU exception.
4234	16948	Internal	"PTP data type <intasdouble> range exceeded" Such extreme parameters have been supplied for the start task, the override or the new target position that the internal data type loses its precision.
4235	16949	Function	"PTP LHL velocity profile cannot be generated" (INTERNAL ERROR) Such extreme parameters have been supplied for the start task, the override or the new target position that it is not possible to generate a velocity profile of the type LHL (Low-High-Low).
4236	16950	Function	"PTP HML velocity profile cannot be generated" (INTERNAL ERROR) Such extreme parameters have been supplied for the override or the new target position that it is not possible to generate a velocity profile of the type HML (High-Middle-Low).
4237	16951	Address	"Start data address is invalid" The address of the start data is invalid.
4238	16952	Parameter	"Velocity override (start override) is not allowed" The value for the velocity override is not allowed, because it is less than 0.0% or more than 100.0% (see axis interface PlcToNc). Here, 100.0 % corresponds to the integral value 1000000 in the axis interface. Value range: [0 ... 1000000]
4239	16953	Parameter	"Start type not allowed" The start type supplied does not exist.
423A	16954	Monitoring	"Velocity overflow (overshoot in the velocity)" The new dynamic with the parameterized jerk is so weak that a velocity overflow will occur (overshoot in the velocity). The command is therefore not supported.
423B	16955	Parameter	"Start parameter for the axis structure is invalid" External or internal parameters for the start structure for a positioning task are invalid. Thus, for instance, the scaling factor, the SAF cycle time or the requested velocity may be less than or equal to zero, which is not allowed.
423C	16956	Parameter	"Override generator initialization parameter invalid" One of the override generator (re)initialization parameters is invalid.
423D	16957	Monitoring	"Slave axis has not set value generator" (INTERNAL ERROR) It is found that a slave axis within a group does not have a valid slave generator (set value generator). A slave axis and a slave set value generator must always be present as a pair. This is an internal error.
423E	16958	Function	"Table is empty" Either the SVB table or the SAF table does not contain any entries.
423F	16959	Function	"Table is full" The SVB table or the SAF table has no more free lines.

Error(Hex)	Error(Dec)	Error Type	Description
4240	16960	Memory	"No memory available" SVB memory allocation for dynamic entry in SAF table failed.
4241	16961	Function	"Table already contains an entry" (INTERNAL ERROR) SAF table entry abandoned, because, incorrectly, an entry already exists.
4242	16962	Function	"Stop is already active" The stop instruction is not forwarded, because it has already been activated.
4243	16963	Function	"Compensation has not been carried out over the full compensation section" The compensations start parameters do not permit compensation over the full section to be compensated. For this reason the compensation will be carried out over a smaller section.
4244	16964	Parameter	"Internal parameters for the compensation are invalid" (INTERNAL ERROR) Invalid internal parameters or start parameters of the lower-level generator.
4245	16965	Function	"Compensation active" Start of compensation refused, because compensation is already active. It's also possible that the M/S axes are not active moved. Therefore an execution of the compensation is impossible.
4246	16966	Function	"Compensation not active" Stop of compensation refused, because compensation is not active.
4247	16967	Function	"Compensation type invalid" The type supplied for the section compensation is invalid. At the present time only compensation type 1 (trapezoidal velocity profile) is allowed.
4248	16968	Function	"Axis address for compensation invalid" (INTERNAL ERROR) The address of the master of slave axis on which the section compensation is to act is invalid. This is an internal error.
4249	16969	Address	"Invalid slave address" (INTERNAL ERROR) The slave address given for on-line coupling/decoupling is invalid.
424A	16970	Function	"Coupling velocity invalid" The velocity of what is to become the master axis is 0, which means that on-line coupling is not possible.
424B	16971	Function	"Coupling velocities not constant" The velocity of what is to become the master axis and the velocity of what is to become the slave axis are not constant, so that on-line coupling is not possible.
424C	16972	Parameter	"Cycle time less than or equal to 0.0 is not allowed" A value less than or equal to 0.0 for the cycle time (Slave) is not allowed, since the cycle time is by definition strictly positive, and with a cycle time of 0.0, division will generate an FPU exception.
424D	16973	Function	"Decoupling task not allowed" The slave axis is of such a type (e.g. a table slave) or is in such a state (master velocity 0) that on-line decoupling is not possible.
424E	16974	Function	"Function not allowed" The function cannot logically be executed, e.g. some commands are not possible and not allowed for slave axes.
424F	16975	Parameter	"No valid table weighting has been set" The weighting factor of each table is 0, so that no table can be read.
4250	16976	Function	"Axis type, actual position type or end position type is not allowed" The start type for a positioning task is invalid. Valid start types are ABSOLUTE (1), RELATIVE (2), CONTINUOUS POSITIVE (3), CONTINUOUS NEGATIVE (4), MODULO (5), etc. It is also possible that the types for setting a new actual position or for travel to a new end position are invalid.

Error(Hex)	Error(Dec)	Error Type	Description
4251	16977	Function	"Function not presently supported" An NC function has been activated that is currently not released for use, or which is not even implemented. This can be a command which is not possible or not allowed for master axes.
4252	16978	Monitoring	"State of state machine invalid" (INTERNAL ERROR) The state of an internal state machine is invalid. This is an internal error.
4253	16979	Monitoring	"Reference cam became free too soon" During the referencing process for an axis it is moved in the direction of the referencing cam, and is only stopped again when the cam signal is reached. After the axis has then also physically stopped, the referencing cam must remain occupied until the axis subsequently starts back down from the cam in the normal way.
4254	16980	Monitoring	"Clearance monitoring between activation of the hardware latch and appearance of the sync pulse" When the clearance monitoring is active, a check is kept on whether the number of increments between activation of the hardware latch and occurrence of the sync pulse (zero pulse) has become smaller than a pre-set value. This error is generated when that happens. (See parameters for the incremental encoder)
4255	16981	Memory	"No memory available" The dynamic memory allocation for the set value generator, the SVB table or the SAF table has failed.
4256	16982	Monitoring	"The table slave axis has no active table" Although the table slave axis has tables, none of the tables is designated as active. If this occurs during the run time the whole master/slave group is stopped by a run time error.
4257	16983	Function	"Function not allowed" The requested function or the requested task is not logically allowed. An example for such an error message would be "set an actual position" for an absolute encoder (M3000, KL5001, etc.).
4258	16984	Function	"Stopping compensation not allowed" It is not possible to stop the compensation, since compensation is already in the stopping phase.
4259	16985	Function	"Slave table is being used" The slave table cannot be activated, because it is currently being used.
425A	16986	Function	"Master or slave axis is processing a job (e.g. positioning command) while coupling is requested" A master/slave coupling of a certain slave type (e.g. linear coupling) cannot be executed. The master or intended slave axis is not in stand still state and is executing a job (e.g. positioning) at the same time as the coupling request received. For this couple type this is not allowed.
425B	16987	Parameter	"Slave (start) parameter is incorrect" One of the slave start/coupling parameters is not allowed (Coupling factor is zero, the master position scaling of an cam is zero, etc.).
425C	16988	Parameter	"Slave type is incorrect" The slave type does not match up to the (SVB) start type.
425D	16989	Function	"Axis stop is already active" The axis stop/Estop is not initiated, because the stop/estop is already active.
425E	16990	Function	"Maximum number of tables per slave generator reached" The maximum number of tables per slave generator is reached (e.g. "MC_MultiCamIn" is limited to 4 tables).

Error(Hex)	Error(Dec)	Error Type	Description
425F	16991	Function	"The scaling mode is invalid" . The used scaling is invalid in this context. Either the mode is not defined or yet not implemented or however it cannot in this constellation be put into action. For example MASTER-AUTOOFFSET cannot be used when a cam table is coupled in relative mode because this is a contradiction. Further MASTER-AUTOOFFSET cannot be used when a cam table is coupled for the first time because a relationship to an existing reference table is missing.
4260	16992	Monitoring	"Controller enable" Controller enable for the axis or for a coupled slave axis is not present (see axis interface PlcToNc). This error occurs if the controller enable is withdrawn while an axis or a group of axes (also a master/slave group) is being actively positioned. The error also occurs if a PTP axis or a coupled slave axis is started without controller enable.
4261	16993	Function	"Table not found" No table exists with the ID prescribed or the table ID is not unique.
4262	16994	Function	"Incorrect table type" The table referred to in the function is of the incorrect type.
4263	16995	Function	"Single step mode" This error occurs if single step mode is selected for a group or axis and a new task is requested while one of the individual tasks is still being processed.
4264	16996	Function	"Group task unknown (asynchronous table entry)" The group has received a task whose type or sub-type is unknown. Valid tasks can be single or multi-dimensional positioning tasks (Geo 1D, Geo 3D), referencing tasks, etc.
4265	16997	Function	"Group function unknown (synchronous function)" The group has received a function whose type is unknown. Valid functions are "Reset", "Stop", "New end position", "Start/stop section compensation", "Set actual position", "Set/reset referencing status" etc.
4266	16998	Function	"Group task for slave not allowed" Group tasks are usually only possible for master axes, not for slave axes. A slave axis only moves as an indirect result of a positioning task given to its associated master axis. A slave can thus never directly be given a task. Exception: see axis parameter "Allow motion commands to slave axis".
4267	16999	Function	"Group function for slave not allowed" Group functions are in principle only possible for master axes, not for slave axes. The only exception is represented by the "Start/stop section compensation" function, which is possible both for masters and for slaves. A slave cannot directly execute any other functions beyond this.
4268	17000	Function	NCI Setpoint Generator is Inactive An NCI command like e.g. "StopAndKeep" is sent to a logically inactive DXD group or to a group with the state channel override zero. Though, it is expected that for performing this command the NCI group resides actively in setpoint generation. This error can occur related to the functions "delete distance to go" and "measurement event (latch actual position)".
4269	17001	Parameter	"Startposition=Setpoint Position" Invalid position parameters.

Error(Hex)	Error(Dec)	Error Type	Description
426A	17002	Parameter	"Parameters of the delay-generator are invalid" Invalid external/internal parameters of the delay generator (delay time, cycle time, tics).
426B	17003	Parameter	"External parameters of the superimposed instruction are invalid" Invalid external parameters of the superimposed functionality (acceleration, deceleration, velocity, process velocity, length).
426C	17004	Parameter	"Invalid override type."
426D	17005	Function	"Activation position under/overrun" The requested activation position is located in the past of the master (e.g. when exchanging a cam table).
426E	17006	Function	"Activation impossible: Master is standing" The required activation of the correction is impossible since the master axis is not moving. A synchronization is not possible, because the master axis standing and the slave axis is still not synchronous.
426F	17007	Function	"Activation mode not possible" The requested activation mode is not possible when the slave axis is moving. Otherwise the slave velocity would jump to zero.
4270	17008	Parameter	"Start parameter for the compensation is invalid" One of the dynamic parameters for the compensation is invalid (necessary condition): Acceleration (>0) Deceleration (>0) Process velocity (>0)
4271	17009	Parameter	"Start parameter for the compensation is invalid" Velocity camber is negative.
4272	17010	Parameter	"Start parameter for the compensation is invalid" The section on which the compensation is to occur is not positive.
4273	17011	Monitoring	"Target position under/overrun" (INTERNAL ERROR) The position (calculated from the modulo-target-position) where the axis should stand at end of oriented stop has been run over.
4274	17012	Monitoring	"Target position will be under/overrun" (INTERNAL ERROR) The position (calculated from the modulo-target-position) where the axis should stand at end of oriented stop is too near and will be run over.
4275	17013	Parameter	Group Parameter is Invalid A group parameter is invalid. In this connection it may be e.g. a parameterized velocity, acceleration, deceleration, jerk or NC cycle time whose value has been parameterized smaller than or equal to zero.
4276	17014	Monitoring	Joint Error at Start of Setpoint Generation At start of setpoint generation for e.g. a flying saw different parameters or states may lead to this error. E.g. dynamic parameters as acceleration, deceleration and jerk may be invalid (smaller than or equal to zero) or the NC cycle time or the override value may reside apart from the interval 0% to 100%.
4277	17015	Monitoring	"Dynamic parameters not permitted" (INTERNAL ERROR) The dynamic parameters resulting from internal calculation like acceleration, deceleration and jerk are not permitted.
4279	17017	Monitoring	The New Target Position is Invalid or Cannot be Reached

Error(Hex)	Error(Dec)	Error Type	Description
			A new commanded target position is invalid because it has already been gone through or will be gone through while stopping with the currently active dynamic.
427A	17018	Monitoring	New Velocity for Moving or the Final Target Velocity is Invalid For a newly commanded command the demanded moving velocity or the demanded final velocity (target velocity in the target position) is invalid. The moving velocity has to be greater than zero value and the final target velocity has always to be greater than or equal to zero (default case is zero value).
427B	17019	Monitoring	The Final Velocity or the New Target Position is Invalid For a newly commanded command the demanded final velocity (target velocity in the target position) or the demanded target position is invalid. The final velocity has to be greater than or equal to zero (default case is zero value).
427C	17020	Monitoring	The New Moving Velocity is Invalid The newly commanded moving velocity is invalid because it is smaller than or equal to zero or other reasons do not facilitate this velocity.
427D	17021	Monitoring	Internal Starting Mode is Invalid For a newly commanded command this starting mode is invalid or is not permitted within this situation of movement. The user cannot influence the starting mode directly.
427E	17022	Monitoring	"A requested motion command could not be realized (BISECTION)" A requested motion command could not be realized using the requested parameters. The command has been executed best possible and this message is therefore to be understood just as a warning. Samples: An axis motion command is requested while the axis is in a unfavorable dynamic situation (acceleration phase), in which the covered distance is too short or the velocity is clearly too high. Another possibility is a slave axis, which is decoupled in motion in an unfavorable dynamic situation and is afterwards given a motion as in the previous case.
427F	17023	Monitoring	"The new target position either has been overrun or will be overrun" The new target position either has been overrun or will be overrun, since until there it is impossible to stop. An internal stop command is commended.
4280	17024	Monitoring	"Group not ready / group not ready for new task" (INTERNAL ERROR / INFORMATION) The group is being given a new task while it is still in the process of executing an existing task. This request is not allowed because it would interrupt the execution of the previous task. The new task could, for instance, be a positioning command, or the "set actual position" function. Precisely the converse relationships apply for the "set new end position" function. In that case, the group/axis must still be actively moving in order to be able to cause a change in the end position.
4281	17025	Parameter	"The parameters of the oriented stop (O-Stop) are not admitted." The modulo-target position should not be smaller than zero and not larger or equal than the encoder mod-period (e.g. in the interval [0.0,360.0]). Note: In the case of error the axis is safely stopped, but is afterwards not at the requested oriented position.

Error(Hex)	Error(Dec)	Error Type	Description
4282	17026	Monitoring	"The modulo target position of the modulo-start is invalid" The modulo target position is outside of the valid parameter range. So the position value should not be smaller than zero and not greater or equal than the encoder modulo-period (e. g. in the interval [0.0,360.0] for the modulo start type "SHORTEST_WAY (261)").
4283	17027	Parameter	"The online change activation mode is invalid" . The activation can be used with online scaling or with online modification of motion function. The used activation is invalid in this context. Either the mode is not defined or yet not implemented or however it cannot in this constellation be put into action (e.g. when linear tables are used with an unexpected cyclic activation mode NEXTCYCLE or NEXTCYCLEONCE). In some case, the activation mode may be valid but the command cannot be executed due to a pending previous command.
4284	17028	Parameter	"The parameterized jerk rate is not permitted" . The jerk rate is smaller than the minimum jerk rate. The minimum value for jerk rate is 1.0 (e.g. mm/s ³).
4285	17029	Parameter	"The parameterized acceleration or deceleration is not permitted" . The parameterized acceleration or deceleration is lower than the permitted minimum acceleration. The value for minimum acceleration is calculated from minimum jerk rate and NC cycle time (minimum jerk rate multiplied with NC cycle time). The unit for example is mm/s ² .
4286	17030	Parameter	"The parameterized velocity is not permitted" . The parameterized target velocity is lower than the minimum velocity (but the value zero is permitted). The value for minimum velocity is calculated from the minimum jerk rate and the NC cycle time (minimum jerk rate multiplied with the square of the NC cycle time). The unit for example is mm/s.
4287	17031	Monitoring	"A activation cannot be executed due to a pending activation" A activation e.g. "CamIn", "CamScaling" or "WriteMotionFunction" cannot be executed due to a pending activation (e.g. "CamIn", "CamScaling", "WriteMotionFunction"). Only activation can be enabled.
4288	17032	Monitoring	"Illegal combination of different cycle times within an axis group" A logical axis group includes elements (axes) with different cycle times for a common setpoint generator and I/O-execution, resp. This situation can occur with Master/Slave-coupling or configuring 3D- and FIFO-groups (including path, auxiliary, and slave axes).
4289	17033	Monitoring	"Illegal motion reversal" Due to the actual dynamical state a motion reversal will happen. To avoid this motion reversal the axis command is not performed and the previous system state restored.
428A	17034	Monitoring	"Illegal moment for an axis command because there is an old axis command with activation position still active" The moment for the command is illegal because there is still an old command with activation position active (e.g. "go to new velocity at threshold position" or "reach new velocity at threshold position").
428B	17035	Monitoring	"Error in the stop-calculation routine" (INTERNAL ERROR) Due to an internal error in the stop-calculation routine the current commando cannot be performed. The previous system state is restored.

Error(Hex)	Error(Dec)	Error Type	Description
428C	17036	Monitoring	"A command with activation position cannot fully be performed because the remaining path is too short" A command with activation position (threshold) like "reach a new velocity at a position" can be just partially executed because the path from the actual position to the activation position is too short.
428D	17037	Monitoring	"Illegal decouple type when decoupling a slave axis" The decouple and restart command contains an invalid decouple type.
428E	17038	Monitoring	"Illegal target velocity when decoupling a slave axis" The decouple and restart command contains an illegal target velocity [$1 < V < V_{max}$].
428F	17039	Monitoring	"The command new dynamic parameter cannot be performed since this would require a new target velocity" Das Kommando zum Aktivieren neuer Dynamikparameter wie Beschleunigung, Verzögerung und Ruck kann nicht durchgeführt werden, da dies eine neue beauftragte Fahrgeschwindigkeit erfordern würde. This situation can occur, for example, if the axis is near the target position in an accelerated state and the dynamics parameter are chosen softer.
4290	17040	Monitoring	"A command with activation position cannot be performed because the axis is already in the brake phase" A command with activation position (threshold) e.g. "reach new velocity at position" cannot be performed because the axis is already in the brake phase and the remaining path from the actual position to the activation position is too short.
4291	17041	Monitoring	"Decouple routine of slave axis doesn't return a valid solution" Internal jerk scaling of decouple routine cannot evaluate a valid solution (decoupling slave axis and transform to master axis). The command is rejected because velocity can become too high, a reversal of movement can occur, or the target position can be passed.
4292	17042	Monitoring	"Command not be executed because the command buffer is full filled" The command is rejected because the command buffer is full filled.
4293	17043	Internal	"Command is rejected due to an internal error in the Look Ahead" (INTERNAL ERROR) The command is rejected due to an internal error in the "look ahead".
4294	17044	Monitoring	"Command is rejected because the segment target velocity is not realized" The command is rejected, because the new target segment velocity V_{requ} is not realizable and an internal optimizing is impossible.
4295	17045	Monitoring	"Successive commands have the same final position" Successive commands have the same final position. So the moving distance is zero.
4296	17046	Monitoring	"Logical positioning direction is inconsistent with the direction of the buffer command" In the extended buffer mode, where the actual end position is replaced by the new buffer start position, the logical positioning direction is inconsistent with the direction of the buffer command (=> contradiction). A buffered command (<i>BufferMode</i> , <i>BlendingLow</i> , <i>BlendingPrevious</i> , <i>BlendingNext</i> , <i>BlendingHigh</i>) is rejected with error 0x4296 if the command is using the Beckhoff specific <i>optional BlendingPosition</i> but the blending position is located beyond the target position of the previous motion command.

Error(Hex)	Error(Dec)	Error Type	Description
4297	17047	Monitoring	"Command is rejected because the remaining positioning length is too small" The command is rejected because the remaining path length is too small. E.g. when the buffer mode is used and the remaining positioning length in the actual segment is too small for getting the axis in a force free state or to reach the new target velocity at the change of segment.
429A	17050	Function	Restart has Failed There is already a motion command within the PTP command buffer and a further new motion command that should have modified the current motion command by restart has failed.
429B	17051	Monitoring	„collect error for invalid start parameters“ This error refers to a wrong parameterization of the user (collect error). E. g. dynamic parameters like Velo, Acc or Dec could be equal or less than zero. Or following errors: - BaseFrequency < 0.0 - StartFrequency < 1.0 - StepCount < 1, StepCount > 200 - BaseAmplitude <= 0.0 - StepDuration <= 0.0 - StopFrequency >= 1/(2*CycleTime)
429C	17052	Monitoring	"Reference cam is not found" During the referencing process for an axis it is moved in the direction of the referencing cam. This reference cam, however, was not found as expected (=> leads to the abortion of the referencing procedure).
429D	17053	Monitoring	"Reference cam became not free" During the referencing process for an axis it is moved in the direction of the referencing cam, and is only stopped again when the cam signal is reached. After the axis has also come to a physical standstill, the axis is subsequently started regularly from the cam again. In this case, the reference cam did not become free again as expected when driving down (=> leads to the abortion of the referencing procedure).
429E	17054	Monitoring	"IO sync pulse was not found (only when using hardware latch)" If the hardware latch is activated, a sync pulse (zero pulse) is expected to be found and a sync event triggered following the expiry of a certain time or a certain distance. If this is not the case, the reaction is an error and the abortion of the referencing procedure.
429F	17055	Function	The Used Buffer Mode is Unknown or not Supported in this Context The buffer mode used for a PTP command (e.g. ABORTING, etc.) is unknown or not supported in this context.
42A0	17056	Internal	"Group/axis consequential error" Consequential error resulting from another causative error related to another axis within the group. Group/axis consequential errors can occur in relation to master/slave couplings or with multiple axis interpolating DXD groups. If, for instance, it is detected that the following error limit of a master axis has been exceeded, then this consequential error is assigned to all the other master axes and slave axes in this group.

Error(Hex)	Error(Dec)	Error Type	Description
42A1	17057	Parameter	"Velocity reduction factor for C0/C1 transition is not allowed" A C0 transition describes two geometries which, while they are themselves continuous, do not have either continuous first or second differentials. The velocity reduction factor C0 acts on such transitions. Note: A C1 transition is characterized by the two geometries being continuous, but having only a first differential that is continuous. The velocity reduction factor C1 acts on such transitions. Value range: [0.0 ... 1.0] Unit: 1
42A2	17058	Parameter	"Critical angle at segment transition not allowed" Value range: (0.0 ... 180.0) Unit: degree
42A3	17059	Parameter	"Radius of the tolerance sphere" is in an invalid range Value range: [0.0 ... 100.0] Unit: e.g. mm
42A4	17060	Parameter	Not implemented.
42A5	17061	Parameter	"Start type" Value range: [0,1] Unit: 1
42A6	17062	Parameter	Not implemented.
42A7	17063	Parameter	"Blending" with given parameters not possible
42A8	17064	Parameter	Not implemented.
42A9	17065	Parameter	"Curve velocity reduction method not allowed" (INTERNAL ERROR) The curve velocity reduction method does not exist.
42AA	17066	Parameter	"Minimum velocity not allowed" The minimum velocity that has been entered is less than 0.0.
42AB	17067	Parameter	"Power function input not allowed" (INTERNAL ERROR) The input parameters in the power_() function lead to an FPU exception.
42AC	17068	Parameter	"Dynamic change parameter not allowed" A parameter that controls alterations to the dynamics is invalid. Parameter: 1. Absolute motion dynamics change: All parameters must be strictly positive. 2. Relative reduction c_f : $0.0 < c_f \leq 1.0$
42AD	17069	Memory	"Memory allocation error" (INTERNAL ERROR)
42AE	17070	Function	"The calculated end position differs from the end position in the nc instruction (internal error)."
42AF	17071	Parameter	"Calculate remaining chord length" invalid value Value range: [0,1]
42B0	17072	Function	"Set value generator SVB active" Starting the set value generator (SVB, SAF) has been refused, since the SVB task is already active.
42B1	17073	Parameter	"SVB parameter not allowed" (INTERNAL ERROR) A parameter related to the internal structure of the set value generator (SVB) results in logical errors and/or to an FPU exception. Affects these parameters: Minimum velocity (>0.0), TimeMode, ModeDyn, ModeGeo, StartType, DistanceToEnd, TBallRadius.
42B2	17074	Parameter	"Velocity reduction factor not allowed" A parameter that controls reduction of the velocity at segment transitions is invalid. Parameter: 1. Transitions with continuous first differential: VeloVertexFactorC1 2. Not once continuously differentiable transitions: VeloVertexFactorC0, CriticalVertexAngleLow, CriticalVertexAngleHigh.

Error(Hex)	Error(Dec)	Error Type	Description
42B3	17075	Parameter	"Helix is a circle" The helix has degenerated to a circle, and should be entered as such.
42B4	17076	Parameter	"Helix is a straight line" The helix has degenerated to a straight line, and should be entered as such.
42B5	17077	Parameter	"Guider parameter not allowed" One of the guider's parameters leads to logical errors and/or to an FPU exception.
42B6	17078	Address	"Invalid segment address" (INTERNAL ERROR) The geometry segment does not have a valid geometry structure address or does not have a valid dynamic structure address.
42B7	17079	Parameter	"Unparameterized generator" (INTERNAL ERROR) The SVB generator is not yet parameterized and is therefore unable to operate.
42B8	17080	Address	"Unparameterized table" (INTERNAL ERROR) The table has no information concerning the address of the corresponding dynamic generator.
42BA	17082	Internal	"The calculation of the arc length of the smoothed path failed (internal error)."
42BB	17083	Parameter	"The radius of the tolerance ball is too small (smaller than 0.1 mm)."
42BC	17084	Internal	Error while calculating DXD-Software-Limit switches (internal error)
42BD	17085	Function	"NC-Block violates software limit switches of the group" At least one path axis with active software limit monitoring has violated the limit switches. Therefore the geometric entry is denied with an error.
42BE	17086	Parameter	"Internal error in the evaluation of a possible software limit switch violation for the segment with the block-number xx." At least one path axis with active position limit monitoring has violated the limit switches.
42BF	17087	Parameter	Invalid reference speed type.
42C0	17088	Internal	"Interpolating group contains axes of an incorrect axis type" An interpolating 3D group may only contain continuously guided axes of axis type 1 (SERVO).
42C1	17089	Internal	"Scalar product cannot be calculated" The length of one of the given vectors is 0.0.
42C2	17090	Internal	"Inverse cosine cannot be calculated" The length of one of the given vectors is 0.0.
42C3	17091	Parameter	"Invalid table entry type" The given table entry type is unknown.
42C4	17092	Parameter	"Invalid DIN66025 information type" (INTERNAL ERROR) The given DIN66025 information type is unknown. Known types: G0, G1, G2, G3, G17, G18, G19.
42C5	17093	Parameter	"Invalid dimension" (INTERNAL ERROR) The CNC dimension is unknown. Known dimensions: 1, 2, 3. Or: The CNC dimension is invalid for the given geometrical object. For a circle the dimension must be 2 or 3, while for a helix it must be 3.
42C6	17094	Parameter	"Geometrical object is not a straight line" The given object, interpreted as a straight line, has a length of 0.0.
42C7	17095	Parameter	"Geometrical object is not a circle" Interpreted as a circular arc, the given object has a length of 0.0, or an angle of 0.0 or a radius of 0.0.
42C8	17096	Parameter	"Geometrical object is not a helix" Interpreted as a circular arc, the given object has a length of 0.0, or an angle of 0.0, or a radius of 0.0. or a height of 0.0.

Error(Hex)	Error(Dec)	Error Type	Description
42C9	17097	Parameter	"Set velocity less than or equal to 0.0 is invalid" A value less than or equal to 0.0 for the set velocity (CNC) is not allowed, since the set velocity is positive by definition, and a set velocity of 0.0 cannot generate any motion.
42CA	17098	Address	"Address for look-ahead invalid" (INTERNAL ERROR) The address supplied for the look-ahead is invalid.
42CB	17099	Function	"Set value generator SAF active" Starting the set value generator (SAF) has been refused, since the SAF task is already active.
42CC	17100	Function	"CNC set value generation not active" Stop or change of override refused, because the set value generation is not active.
42CD	17101	Function	"CNC set value generation in the stop phase" Stop or change of override refused, because the set value generation is in the stop phase.
42CE	17102	Parameter	"Override not allowed" An override of less than 0.0 % or more than 100.0 % is invalid.
42CF	17103	Address	"Invalid table address" (INTERNAL ERROR) The table address given for the initialization of the set value generator is invalid, or no valid logger connection (report file) is present.
42D0	17104	Parameter	"Invalid table entry type" The given table entry type is unknown.
42D1	17105	Memory	"Memory allocation failed" Memory allocation for the table has failed.
42D2	17106	Memory	"Memory allocation failed" Memory allocation for the filter has failed.
42D3	17107	Parameter	"Invalid parameter" Filter parameter is not allowed.
42D4	17108	Function	"Delete Distance To Go failed" Delete Distance to go (only interpolation) failed. This error occurred, if e.g. the command 'DelDTG' was not programmed in the actual movement of the nc program.
42D5	17109	Internal	"The setpoint generator of the flying saw generates incompatible values (internal error)"
42D6	17110	Function	"Axis will be stopped since otherwise it will overrun its target position (old PTP setpoint generator)" If, for example, in case of a slave to master transformation for the new master a target position is commanded that will be overrun because of the actual dynamics the axis will be stopped internally to guarantee that the target position will not be overrun.
42D7	17111	Function	"Internal error in the transformation from slave to master."
42D8	17112	Function	"Wrong direction in the transformation of slave to master."
42DA	17114	Parameter	"Parameter of Motion Function (MF) table incorrect" The parameter of the Motion Function (MF) are invalid. This may refer to the first time created data set or to online changed data.
42DB	17115	Parameter	"Parameter of Motion Function (MF) table incorrect" The parameter of the Motion Function (MF) are invalid. This may refer to the first time created data set or to online changed data. The error cause can be, that an active MF point (no IGNORE point) points at a passive MF point (IGNORE point).

Error(Hex)	Error(Dec)	Error Type	Description
42DC	17116	Monitoring	"Internal error by using Motion Function (MF)" An internal error occurs by using the Function (MF). This error cannot be solved by the user. Please ask the TwinCAT Support.
42DD	17117	Function	"Axis coupling with synchronization generator declined because of incorrect axis dynamic values" The axis coupling with the synchronization generator has been declined, because one of the slave dynamic parameter (machine data) is incorrect. Either the maximum velocity, the acceleration, the deceleration or the jerk is smaller or equal to zero, or the expected synchronous velocity of the slave axis is higher as the maximum allowed slave velocity.
42DE	17118	Function	"Coupling conditions of synchronization generator incorrect" During positive motion of the master axis it has to be considered, that the master synchronous position is larger than the master coupling position ("to be in the future"). During negative motion of the master axis it has to be considered that the master synchronous position is smaller than the master coupling position.
42DF	17119	Monitoring	"Moving profile of synchronization generator declines dynamic limit of slave axis or required characteristic of profile" One of the parameterized checks has recognized an overstepping of the dynamic limits (max. velocity, max. acceleration, max. deceleration or max. jerk) of the slave axis, or an profile characteristic (e.g. overshoot or undershoot in the position or velocity) is incorrect. See also further messages in the windows event log and in the message window of the System Manager.
42E0	17120	Parameter	"Invalid parameter" The encoder generator parameter is not allowed.
42E1	17121	Parameter	"Invalid parameter" The external (Fifo) generator parameter is not allowed.
42E2	17122	Function	"External generator is active" The external generator cannot be started, as it is already active.
42E3	17123	Function	"External generator is not active" The external generator cannot be stopped, as it is not active.
42E4	17124	Function	"NC-Block with auxiliary axis violates software limit switches of the group" At least one auxiliary axis with active software limit monitoring has violated the limit switches. Therefore the geometric entry is denied with an error.
42E5	17125	Function	"NC-Block type Bezier spline curve contains a cusp (singularity)" The Bezier spline curve contain a cusp, i.e. at a certain interior point both the curvature and the modulus of the velocity tend to 0 such that the radius of curvature is infinite. Note: Split the Bezier curve at that point into two Bezier spline curves according to the de "Casteljau algorithm". This preserves the geometry and eliminates the interior singularity.
42E7	17127	Parameter	"Value for dead time compensation not allowed" The value for the dead time compensation in seconds for a slave coupling to an encoder axis (virtual axis) is not allowed. Value range: [0.0 ... 60.0] Unit: s
42E8	17128	Parameter	"GROUPERR_RANGE_NOMOTIONWINDOW" Value range: [0.0 ... 1000.0] Unit: e.g. mm/s
42E9	17129	Parameter	"GROUPERR_RANGE_NOMOTIONFILTERTIME"

Error(Hex)	Error(Dec)	Error Type	Description
			Value range: [0.0 ... 60.0] Unit: s
42EA	17130	Parameter	"GROUPERR_RANGE_TIMEUNITFIFO" Value range: (0.0 ... 1000.0) Unit: s
42EB	17131	Parameter	"GROUPERR_RANGE_OVERRIDETYPE" Value range: [1, 2] Unit: 1
42EC	17132	Parameter	"GROUPERR_RANGE_OVERRIDECHANGETIME" Value range: (0.0 ... 1000.0) Unit: s
42ED	17133	Parameter	"GROUPERR_FIFO_INVALIDDIMENSION" Note: Since TC 2.11 Build 1547 the FIFO-dimension (number of axes) has been increased from 8 to 16. Value range: [1 ... 8] resp. [1 ... 16] Unit: 1 (number of axes)
42EE	17134	Address	"GROUPERR_ADDR_FIFOTABLE"
42EF	17135	Monitoring	" Axis is locked for motion commands because a stop command is still active " The axis/group is locked for motion commands because a stop command is still active. The axis can be released by calling <i>MC_Stop</i> with <i>Execute=FALSE</i> or by using <i>MC_Reset (TcMC2.Lib)</i> .
42F0	17136	Parameter	" Invalid number of auxiliary axes " The local number of auxiliary axes does not tally with the global number of auxiliary axes.
42F1	17137	Parameter	" Invalid reduction parameter for auxiliary axes " The velocity reduction parameters for the auxiliary axes are inconsistent.
42F2	17138	Parameter	" Invalid dynamic parameter for auxiliary axes " The dynamic parameters for the auxiliary axes are inconsistent.
42F3	17139	Parameter	" Invalid coupling parameter for auxiliary axes " The coupling parameters for the auxiliary axes are inconsistent.
42F4	17140	Parameter	" Invalid auxiliary axis entry " The auxiliary axis entry is empty (no axis motion).
42F6	17142	Parameter	" Invalid parameter " The limit for velocity reduction of the auxiliary axes is invalid. It has to be in the interval 0..1.0
42F8	17144	Parameter	" Block search - segment not found " The segment specified as a parameter could not be found by the end of the NC program. Possible cause: <ul style="list-style-type: none"> nBlockId is not specified in the mode described by eBlockSearchMode
42F9	17145	Parameter	" Blocksearch – invalid remaining segment length " The remaining travel in the parameter fLength is incorrectly parameterized
42FB	17147	Internal	Internal Error in the Context of Coupled Axes (Slave Axes) Fatal internal error using coupled axes (slave axes). Inconsistent internal state. Please, contact the support team.
42FC	17148	Parameter	Parameter for the Maximum Number of Jobs (Entries) to be Transferred is Invalid The parameter that describes the maximum number of entries to transfer from the SVB to the SAF table per NC Cycle is invalid. Range of values: [1, 20] Unit: 1
42FF	17151	Monitoring	Customer Specific Error

Error(Hex)	Error(Dec)	Error Type	Description
			In this connection it is about a customer specific monitoring function.

6.2.4 Axis Errors

Error(Hex)	Error(Dec)	Error Type	Description
4300	17152	Parameter	"Axis ID not allowed" The value for the axis ID is not allowed, e.g. because it has already been assigned, is less than or equal to zero, is greater than 255, or does not exist in the current configuration.
			Value range: [1 ... 255] Unit: 1
4301	17153	Parameter	"Axis type not allowed" The value for the axis type is unacceptable because it is not defined. Type 1: Servo Type 2: Fast/creep Type 3: Stepper motor
			Value range: [1 ... 3] Unit: 1
4306	17158	Parameter	"Slow manual velocity not allowed" The value for the slow manual velocity is not allowed.
			Value range: [0.0, 10000.0] Unit: e.g. m/min
4307	17159	Parameter	"Fast manual velocity not allowed" The value for the fast manual velocity is not allowed.
			Value range: [0.0, 10000.0] Unit: e.g. m/min
4308	17160	Parameter	"High speed not allowed" The value for the high speed is not allowed.
			Value range: [0.0, 10000.0] Unit: e.g. m/min
4309	17161	Parameter	"Acceleration not allowed" The value for the axis acceleration is not allowed.
			Value range: [0.0, 1000000.0] Unit: e.g. m/s/s
430A	17162	Parameter	"Deceleration not allowed" The value for the axis deceleration is not allowed.
			Value range: [0.0, 1000000.0] Unit: e.g. m/s/s
430B	17163	Parameter	"Jerk not allowed" The value for the axis jerk is not allowed.
			Value range: [0.0, 1000000.0] Unit: e.g. m/s/s/s
430C	17164	Parameter	"Delay time between position and velocity is not allowed" The value for the delay time between position and velocity ("idle time compensation") is not allowed.
			Value range: [0, 0.1] Unit: s
430D	17165	Parameter	"Override-Type not allowed" The value for the velocity override type is not allowed. Type 1: With respect to the internal reduced velocity (default value) Type 2: With respect to the original external start velocity
			Value range: [1 ... 4] Unit: 1
430E	17166	Parameter	"NCI: Velo-Jump-Factor not allowed" The value for the velo-jump-factor ("VeloJumpFactor") is not allowed. This parameter only works for TwinCAT NCI.
			Value range: [0, 1000000] Unit: 1

Error(Hex)	Error(Dec)	Error Type	Description
430F	17167	Parameter	<p>"NCI: Radius of tolerance sphere for the auxiliary axes is invalid" It was tried to enter an invalid value for the size of the tolerance sphere. This sphere affects only auxiliary axes!</p> <p>Value range: [0, 1000] Unit: e.g. mm</p>
4310	17168	Parameter	<p>"NCI: Value for maximum deviation for the auxiliary axes is invalid" It was tried to enter an invalid value for the maximum allowed deviation. This parameter affects only auxiliary axes!</p> <p>Value range: [0, 10000] Unit: e.g. mm</p>
4312	17170	Parameter	<p>"Referencing velocity in direction of cam not allowed" The value for the referencing velocity in the direction of the referencing cam is not allowed.</p> <p>Value range: [0.0, 10000.0] Unit: e.g. m/min</p>
4313	17171	Parameter	<p>"Referencing velocity in sync direction not allowed" The value for the referencing velocity in the direction of the sync pulse (zero track) is not allowed.</p> <p>Value range: [0.0, 10000.0] Unit: e.g. m/min</p>
4314	17172	Parameter	<p>"Pulse width in positive direction not allowed" The value for the pulse width in the positive direction is not allowed (pulsed operation). The use of the pulse width for positioning is chosen implicitly through the axis start type. Pulsed operation corresponds to positioning with a relative displacement that corresponds precisely to the pulse width.</p> <p>Value range: [0.0, 1000000.0] Unit: e.g. mm</p>
4315	17173	Parameter	<p>"Pulse width in negative direction not allowed" The value for the pulse width in the negative direction is not allowed (pulsed operation). The use of the pulse width for positioning is chosen implicitly through the axis start type. Pulsed operation corresponds to positioning with a relative displacement that corresponds precisely to the pulse width.</p> <p>Value range: [0.0, 1000000.0] Unit: e.g. mm</p>
4316	17174	Parameter	<p>"Pulse time in positive direction not allowed" The value for the pulse width in the positive direction is not allowed (pulsed operation).</p> <p>Value range: [0.0, 600.0] Unit: s</p>
4317	17175	Parameter	<p>"Pulse time in negative direction not allowed" The value for the pulse width in the negative direction is not allowed (pulsed operation).</p> <p>Value range: [0.0, 600.0] Unit: s</p>
4318	17176	Parameter	<p>"Creep distance in positive direction not allowed" The value for the creep distance in the positive direction is not allowed.</p> <p>Value range: [0.0, 100000.0] Unit: e.g. mm</p>
4319	17177	Parameter	<p>"Creep distance in negative direction not allowed" The value for the creep distance in the negative direction is not allowed.</p> <p>Value range: [0.0, 100000.0] Unit: e.g. mm</p>
431A	17178	Parameter	<p>"Braking distance in positive direction not allowed" The value for the braking distance in the positive direction is not allowed.</p> <p>Value range: [0.0, 100000.0] Unit: e.g. mm</p>

Error(Hex)	Error(Dec)	Error Type	Description
431B	17179	Parameter	"Braking distance in negative direction not allowed" The value for the braking distance in the negative direction is not allowed.
			Value range: [0.0, 100000.0] Unit: e.g. mm
431C	17180	Parameter	"Braking time in positive direction not allowed" The value for the braking time in the positive direction is not allowed.
			Value range: [0.0, 60.0] Unit: s
431D	17181	Parameter	"Braking time in negative direction not allowed" The value for the braking time in the negative direction is not allowed.
			Value range: [0.0, 60.0] Unit: s
431E	17182	Parameter	"Switching time from high to low speed not allowed" The value for the time to switch from high to low speed is not allowed.
			Value range: [0.0, 60.0] Unit: s
431F	17183	Parameter	"Creep distance for stop not allowed" The value for the creep distance for an explicit stop is not allowed.
			Value range: [0.0, 100000.0] Unit: e.g. mm
4320	17184	Parameter	"Motion monitoring not allowed" The value for the activation of the motion monitoring is not allowed.
			Value range: [0, 1] Unit: 1
4321	17185	Parameter	"Position window monitoring not allowed" The value for the activation of the position window monitoring is not allowed.
			Value range: [0, 1] Unit: 1
4322	17186	Parameter	"Target window monitoring not allowed" The value for the activation of target window monitoring is not allowed.
			Value range: [0, 1] Unit: 1
4323	17187	Parameter	"Loop not allowed" The value for the activation of loop movement is not allowed.
			Value range: [0, 1] Unit: 1
4324	17188	Parameter	"Motion monitoring time not allowed" The value for the motion monitoring time is not allowed.
			Value range: [0.0, 600.0] Unit: s
4325	17189	Parameter	"Target window range not allowed" The value for the target window is not allowed.
			Value range: [0.0, 10000.0] Unit: e.g. mm
4326	17190	Parameter	"Position window range not allowed" The value for the position window is not allowed.
			Value range: [0.0, 10000.0] Unit: e.g. mm
4327	17191	Parameter	"Position window monitoring time not allowed" The value for the position window monitoring time is not allowed.
			Value range: [0.0, 600.0] Unit: s
4328	17192	Parameter	"Loop movement not allowed" The value for the loop movement is not allowed.
			Value range: [0.0, 10000.0] Unit: e.g. mm
4329	17193	Parameter	"Axis cycle time not allowed" The value for the axis cycle time is not allowed.
			Value range: [0.001, 0.1] Unit: s

Error(Hex)	Error(Dec)	Error Type	Description
432A	17194	Parameter	"Stepper motor operating mode not allowed" The value for the stepper motor operating mode is not allowed.
			Value range: [1, 2] Unit: 1
432B	17195	Parameter	"Displacement per stepper motor step not allowed" The value for the displacement associated with one step of the stepper motor is not allowed (step scaling).
			Value range: [0.000001, 1000.0] Unit: e.g. mm/STEP
432C	17196	Parameter	"Minimum speed for stepper motor set value profile not allowed" The value for the minimum speed of the stepper motor speed profile is not allowed.
			Value range: [0.0, 1000.0] Unit: z. B. m/min
432D	17197	Parameter	"Stepper motor stages for one speed stage not allowed" The value for the number of steps for each speed stage in the set value generation is not allowed.
			Value range: [0, 100] Unit: 1
432E	17198	Parameter	"DWORD for the interpretation of the axis units not allowed" The value that contains the flags for the interpretation of the position and velocity units is not allowed.
			Value range: [0, 0xFFFFFFFF] Unit: 1
432F	17199	Parameter	"Maximum velocity not allowed" The value for the maximum permitted velocity is not allowed.
			Value range: [0.0, 10000.0] Unit: e.g. m/min
4330	17200	Parameter	"Motion monitoring window not allowed" The value for the motion monitoring window is not allowed.
			Value range: [0.0, 10000.0] Unit: e.g. mm
4331	17201	Parameter	"PEH time monitoring not allowed" The value for the activation of the PEH time monitoring is not allowed (PEH: positioning end and halt).
			Value range: [0, 1] Unit: 1
4332	17202	Parameter	"PEH monitoring time not allowed" The value for the PEH monitoring time (timeout) is not allowed (PEH: positioning end and halt). default value: 5s
			Value range: [0.0, 600.0] Unit: s
4333	17203	Parameter	Parameter "Break Release Delay" is Invalid The parameter for Break Release Delay of a discrete (two speed) axis is invalid.
			Range of values: [0.0, 60.0] Unit: s
4334	17204	Parameter	Parameter "NC Data Persistence" is Invalid The boolean parameter NC Data Persistence of an axis is invalid.
			Range of values: [0, 1] Unit: 1
4335	17205	Parameter	Parameter for the Error Reaction Mode is Invalid The parameter for the error reaction mode of the axis is invalid (instantaneous, delayed).
			Range of values: [0, 1] Unit: 1
4336	17206	Parameter	Parameter for the Error Reaction Delay is Invalid The parameter for the error reaction delay of the axis is invalid.
			Range of values: [0.0, 1000.0] Unit: s

Error(Hex)	Error(Dec)	Error Type	Description
4337	17207	Parameter	Parameter “Couple Slave to Actual Values if not Enabled” is Invalid The parameter “Couple Slave to Actual Values if not Enabled” is invalid.
			Range of values: [0, 1] Unit: 1
4338	17208	Parameter	Parameter "Allow Motion Commands to Slave Axis" is Invalid The boolean parameter “Allow Motion Commands to Slave Axis” is invalid. This parameter defines whether a motion command can be sent to a slave axis or whether this is rejected with the NC error 0x4266 or 0x4267.
			Range of values: [0, 1] Unit: 1
4339	17209	Parameter	Parameter “Allow Motion Commands to External Setpoint Axis” is Invalid The boolean parameter “Allow Motion Commands to External Setpoint Axis” is invalid. This parameter defines whether a motion command may be send to an axis within the state of external setpoint generation or whether such a message is rejected with error 0x4257.
			Range of values: [0, 1] Unit: 1
433A	17210	Parameter	Parameter “Fading Acceleration” is Invalid The parameter “Fading Acceleration” for the blending profile from set to actual values is invalid. This parameter defines how to blend from a setpoint based axis coupling to an actual value based coupling (indirectly there is a time for the blending). Note: The value 0.0 causes that the minimum of default acceleration and default deceleration is used as blending acceleration internally within the NC.
			Range of values: [0; 0.01 .. 1.0e+20] Unit: e.g. mm/s^2

Error(Hex)	Error(Dec)	Error Type	Description
433B	17211	Parameter	"Fast Axis Stop Signal Type not allowed" The value for the Signal Type of the 'Fast Axis Stop' is not allowed [0...5].
4340	17216	Initialization	"Axis initialization" Axis has not been initialized. Although the axis has been created, the rest of the initialization has not been performed (1. Initialization of axis I/O, 2. Initialization of axis, 3. Reset axis).
4341	17217	Address	"Group address" Axis does not have a group, or the group address has not been initialized (group contains the set value generation).
4342	17218	Address	"Encoder address" The axis does not have an encoder, or the encoder address has not been initialized.
4343	17219	Address	"Controller address" The axis does not have a controller, or the controller address has not been initialized.
4344	17220	Address	"Drive address" The axis does not have a drive, or the drive address has not been initialized.
4345	17221	Address	"Axis interface PLC to NC address" Axis does not have an axis interface from the PLC to the NC, or the axis interface address has not been initialized.

Error(Hex)	Error(Dec)	Error Type	Description
4346	17222	Address	"Axis interface NC to PLC address" Axis does not have an axis interface from the NC to the PLC, or the axis interface address has not been initialized.
4347	17223	Address	"Size of axis interface NC to PLC is not allowed" (INTERNAL ERROR) The size of the axis interface from NC to PLC is not allowed.
4348	17224	Address	"Size of axis interface PLC to NC is not allowed" (INTERNAL ERROR) The size of the axis interface from PLC to NC is not allowed.
4356	17238	Monitoring	"Controller enable" Controller enable for the axis is not present (see axis interface SPS@NC). This enable is required, for instance, for an axis positioning task.
4357	17239	Monitoring	Feed enable negative: There is no feed enable for negative motion direction (see axis interface PLC->NC). This enable is checked e.g. for a positioning task of an axis into negative motion direction.
4358	17240	Monitoring	"Feed enable plus" Feed enable for movement in the positive direction is not present (see axis interface SPS@NC). This enable is required, for instance, for an axis positioning task in the positive direction.
4359	17241	Monitoring	"Set velocity not allowed" The set velocity requested for a positioning task is not allowed. This can happen if the velocity is less than or equal to zero, larger than the maximum permitted axis velocity, or, in the case of servo-drives, is larger than the reference velocity of the axis (see axis and drive parameters).
435A	17242	Monitoring	"Movement smaller than one encoder increment" (INTERNAL ERROR) The movement required of an axis is, in relation to a positioning task, smaller than one encoder increment (see scaling factor). This information is, however, handled internally in such a way that the positioning is considered to have been completed without an error message being returned.
435B	17243	Monitoring	"Set acceleration monitoring" (INTERNAL ERROR) The set acceleration has exceeded the maximum permitted acceleration or deceleration parameters of the axis.
435C	17244	Monitoring	"PEH time monitoring" The PEH time monitoring has detected that, after the PEH monitoring time that follows a positioning has elapsed, the target position window has not been reached. The following points must be checked: Is the PEH monitoring time, in the sense of timeout monitoring, set to a sufficiently large value (e.g. 1-5 s)? The PEH monitoring time must be chosen to be significantly larger than the target position monitoring time. Have the criteria for the target position monitoring (range window and time) been set too strictly? Note: The PEH time monitoring only functions when target position monitoring is active!
435D	17245	Monitoring	"Encoder existence monitoring / movement monitoring" During the active positioning the actual encoder value has changed continuously for a default check time from NC cycle to NC cycle less than the default minimum movement limit. => Check, whether axis is mechanically blocked, or the encoder system failed, etc... Note: The check is not performed while the axis is logically standing (position control), but only at active positioning (it would make no sense if there is a mechanical holding brake at the standstill)!

Error(Hex)	Error(Dec)	Error Type	Description
435E	17246	Monitoring	"Looping distance less than breaking distance" The absolute value of the looping distance is less or equal than the positive or negative breaking distance. This is not allowed.
435F	17247	Monitoring	Starting Velocity Invalid The required starting velocity for a positioning task is not permitted (usually the starting velocity is zero). This situation can occur if the velocity is smaller than or equal to zero, greater than the axis maximum permitted velocity or for servo motion controllers greater than the axis reference velocity (see axis and motion controller parameters).
4360	17248	Monitoring	Final Velocity Invalid The required final velocity for a positioning task is not permitted (normally the final velocity is zero). This situation can occur if the velocity is smaller than or equal to zero, greater than the axis maximum permitted velocity or for servo motion controllers greater than the axis reference velocity (see axis and motion controller parameters).
4361	17249	Monitoring	"Time range exceeded (future)" The calculated position lies too far in the future (e.g. when converting a position value in a DC time stamp).
4362	17250	Monitoring	"Time range exceeded (past)" The calculated position lies too far in the past (e.g. when converting a position value in a DC time stamp).
4363	17251	Monitoring	"Position cannot be determined" The requested position cannot be determined. Case 1: It was not passed through in the past. Case 2: It cannot be reached in future. A reason can be a zero velocity value or an acceleration that causes a turn back.
4364	17252	Monitoring	"Position indeterminable (conflicting direction of travel)" The direction of travel expected by the caller of the function deviates from the actual direction of travel (conflict between PLC and NC view, for example when converting a position to a DC time).
4370	17264	Monitoring	No Slave Coupling Possible (Velocity Violation) A slave coupling to a master axis (e.g. by a universal flying saw) is rejected because otherwise the maximum velocity of the slave axis would be exceeded (a velocity monitoring has been selected).
4371	17265	Monitoring	No Slave Coupling Possible (Acceleration Violation) A slave coupling to a master axis (e.g. by a universal flying saw) is rejected, because otherwise the maximum acceleration of the slave axis will be exceeded (an acceleration monitoring is selected).
4372 – 438B	17266 – 17291		See TF5055 NC Flying Saw – Error Codes
43A0	17312	Internal	"Axis consequential error" Consequential error resulting from another causative error related to another axis. Axis consequential errors can occur in relation to master/slave couplings or with multiple axis interpolating DXD groups.

6.2.5 Encoder Errors

Error(Hex)	Error(Dec)	Error Type	Description
4400	17408	Parameter	"Encoder ID not allowed" The value for the encoder ID is not allowed, e.g. because it has already been assigned, is less than or equal to zero, or is bigger than 255.
			Value range: [1 ... 255] Unit: 1
4401	17409	Parameter	"Encoder type not allowed" The value for the encoder type is unacceptable because it is not defined. Type 1: Simulation (incremental) Type 2: M3000 (24 bit absolute) Type 3: M31x0 (24 bit incremental) Type 4: KL5101 (16 bit incremental) Type 5: KL5001 (24 bit absolute SSI) Type 6: KL5051 (16 bit BISSI)
			Value range: [1 ... 6] Unit: 1
4402	17410	Parameter	"Encoder mode" The value for the encoder (operating) mode is not allowed. Mode 1: Determination of the actual position Mode 2: Determination of the actual position and the actual velocity (filter)
			Value range: [1, 2] Unit: 1
4403	17411	Parameter	"Encoder counting direction inverted?" The flag for the encoder counting direction is not allowed. Flag 0: Positive encoder counting direction Flag 1: Negative encoder counting direction
			Value range: [0, 1] Unit: 1
4404	17412	Initialization	"Referencing status" The flag for the referencing status is not allowed. Flag 0: Axis has not been referenced Flag 1: Axis has been referenced
			Value range: [0, 1] Unit: 1
4405	17413	Parameter	"Encoder increments for each physical encoder rotation" The value for the number of encoder increments for each physical rotation of the encoder is not allowed. This value is used by the software for the calculation of encoder overruns and underruns.
			Value range: [255, 0xFFFFFFFF] Unit: INC
Error(Hex)	Error(Dec)	Error Type	Description
4406	17414	Parameter	"Scaling factor" The value for the scaling factor is not allowed. This scaling factor provides the weighting for the conversion of an encoder increment (INC) to a physical unit such as millimeters or degrees.
			Value range: [0.000001, 100.0] Unit: e.g. mm/INC
4407	17415	Parameter	"Position offset (zero point offset)" The value for the position offset of the encoder is not allowed. This value is added to the calculated encoder position, and is interpreted in the physical units of the encoder.
			Value range: [-1000000.0, 1000000.0] Unit: e.g. mm
4408	17416	Parameter	"Modulo factor" The value for the encoder's modulo factor is not allowed.
			Value range: [1.0, 1000000.0] Unit: e.g. mm
4409	17417	Parameter	"Position filter time" The value for the actual position filter time is not allowed (P-T1 filter).
			Value range: [0.0, 60.0] Unit: s
440A	17418	Parameter	"Velocity filter time" The value for the actual velocity filter time is not allowed (P-T1 filter).
			Value range: [0.0, 60.0] Unit: s
440B	17419	Parameter	"Acceleration filter time" The value for the actual acceleration filter time is not allowed (P-T1 filter).

Error(Hex)	Error(Dec)	Error Type	Description
			Value range: [0.0, 60.0] Unit: s
440C	17420	Initialization	"Cycle time not allowed" (INTERNAL ERROR) The value of the SAF cycle time for the calculation of actual values is not allowed (e.g. is less than or equal to zero).
440D	17421	Initialization	"Configuration of the selected units is invalid" E.g. settings for modulo position, velocity per minute etc. lead to an error.
440E	17422	Parameter	"Actual position correction / measurement system error correction" The value for the activation of the actual position correction ("measuring system error correction") is not allowed. Value range: [0, 1] Unit: 1
440F	17423	Parameter	"Filter time actual position correction" The value for the actual position correction filter time is not allowed (P-T1 filter). Value range: [0.0, 60.0] Unit: s
4410	17424	Parameter	"Search direction for referencing cam inverted" The value of the search direction of the referencing cam in a referencing procedure is not allowed. Value 0: Positive direction Value 1: Negative direction Value range: [0, 1] Unit: 1
4411	17425	Parameter	"Search direction for sync pulse (zero pulse) inverted" The value of the search direction of the sync pulse (zero pulse) in a referencing procedure is not allowed. Value 0: Positive direction Value 1: Negative direction Value range: [0, 1] Unit: 1
4412	17426	Parameter	"Reference position" The value of the reference position in a referencing procedure is not allowed. Value range: [-1000000.0, 1000000.0] Unit: e.g. mm
4413	17427	Parameter	"Clearance monitoring between activation of the hardware latch and appearance of the sync pulse" (NOT IMPLEMENTED) The flag for the clearance monitoring between activation of the hardware latch and occurrence of the sync/zero pulse ("latch valid") is not allowed. Value 0: Passive Value 1: Active Value range: [0, 1] Unit: 1
4414	17428	Parameter	"Minimum clearance between activation of the hardware latch and appearance of the sync pulse" (NOT IMPLEMENTED) The value for the minimum clearance in increments between activation of the hardware latch and occurrence of the sync/zero pulse ("latch valid") during a referencing procedure is not allowed. Value range: [0, 65536] Unit: INC
4415	17429	Parameter	"External sync pulse" (NOT IMPLEMENTED) The value of the activation or deactivation of the external sync pulse in a referencing procedure is not allowed. Value 0: Passive Value 1: Active Value range: [0, 1] Unit: 1
4416	17430	Parameter	"Scaling of the noise rate is not allowed" The value of the scaling (weighting) of the synthetic noise rate is not allowed. This parameter exists only in the simulation encoder and serves to produce a realistic simulation. Value range: [0, 1000000] Unit: 1
4417	17431	Parameter	„Tolerance window for modulo-start“ The value for the tolerance window for the modulo-axis-start is invalid. The value must be greater or equal than zero and smaller than the half encoder modulo-period (e. g. in the interval [0.0,180.0)).

Error(Hex)	Error(Dec)	Error Type	Description
			Value range: [0.0, 180], Max: 0.5*modulo-periode Unit: e. g. mm or degree
4418	17432	Parameter	„Encoder reference mode“ The value for the encoder reference mode is not allowed, resp. is not supported for this encoder type. Value range: [0, 5] Unit: 1
4419	17433	Parameter	„Encoder evaluation direction“ The value for the encoder evaluation direction (log. counter direction) is not allowed. Value range: [0, 3] Unit: 1
441A	17434	Parameter	„Encoder reference system“ The value for the encoder reference system is invalid (0: incremental, 1: absolute, 2: absolute+modulo). Value range: [0, 2] Unit: 1
441B	17435	Parameter	„Encoder position initialization mode“ When starting the TC system the value for the encoder position initialization mode is invalid. Value range: [0, 1] Unit: 1
441C	17436	Parameter	„Encoder sign interpretation (UNSIGNED- / SIGNED- data type)“ The value for the encoder sign interpretation (data type) for the encoder the actual increment calculation (0: Default/not defined, 1: UNSIGNED, 2:/ SIGNED) is invalid. Value range: [0, 2] Unit: 1
441D	17437	Parameter	„Homing Sensor Source“ The value for the encoder homing sensor source is not allowed, resp. is not supported for this encoder type. Value range: [0, 16] Unit: 1
4420	17440	Parameter	„Software end location monitoring minimum not allowed“ The value for the activation of the software location monitoring minimum is not allowed. Value range: [0, 1] Unit: 1
4421	17441	Parameter	„Software end location monitoring maximum not allowed“ The value for the activation of the software location monitoring maximum is not allowed. Value range: [0, 1] Unit: 1
4422	17442	Function	„Actual value setting is outside the value range“ The "set actual value" function cannot be carried out, because the new actual position is outside the expected range of values. Value range: [-1000000.0, 1000000.0] Unit: e.g. mm
4423	17443	Parameter	„Software end location minimum not allowed“ The value for the software end location minimum is not allowed. Value range: [-1000000000.0, 1000000000.0] Unit: e.g. mm
4424	17444	Parameter	„Software end location maximum not allowed“ The value for the software end location maximum is not allowed. Value range: [-1000000000.0, 1000000000.0] Unit: e.g. mm
4425	17445	Parameter	„Filter mask for the raw data of the encoder is invalid“ The value for the filter mask of the encoder raw data in increments is invalid. Value range: [0, 0xFFFFFFFF] Unit: 1
4426	17446	Parameter	„Reference mask for the raw data of the encoder is invalid“ The value for the reference mask (increments per encoder turn, absolute resolution) for the raw data of the

Error(Hex)	Error(Dec)	Error Type	Description
			encoder is invalid. E.g. this value is used for axis reference sequence (calibration) with the reference mode "Software Sync". Value range: [0x0000000F, 0xFFFFFFFF] Unit: 1
4427	17447	Parameter	Parameter Dead Time Compensation Mode (Encoder) is Invalid The parameter for the mode of dead time compensation at the NC encoder is invalid (OFF, ON with velocity, ON with velocity and acceleration). Range of values: [0, 1, 2] Unit: 1
4428	17448	Parameter	Parameter "Control Bits of Dead Time Compensation" (Encoder) is Invalid The parameter for the control bits of dead time compensation at the encoder is invalid (e.g. relative or absolute time interpretation). Range of values: [>0] Unit: 1
4429	17449	Parameter	Parameter "Time Related Shift of Dead Time Compensation Mode" (Encoder) is Invalid The parameter for time related shift of dead time compensation (time shift in nanoseconds) at the encoder is invalid. Range of values: [-1.0E9 .. 1.0E9] Unit: ns
4430	17456	Function	"Hardware latch activation (encoder)" Activation of the encoder hardware latch was implicitly initiated by the referencing procedure. If this function has already been activated but a latch value has not yet become valid ("latch valid"), another call to the function is refused with this error.
4431	17457	Function	"External hardware latch activation (encoder)" The activation of the external hardware latch (only available on the KL5101) is initiated explicitly by an ADS command (called from the PLC program of the Visual Basic interface). If this function has already been activated, but the latch value has not yet been made valid by an external signal ("external latch valid"), another call to the function is refused with this error.
4432	17458	Function	"External hardware latch activation (encoder)" If a referencing procedure has previously been initiated and the hardware still signals a valid latch value ("latch valid"), this function must not be called. In practice, however, this error can almost never occur.
4433	17459	Function	"External hardware latch activation (encoder)" If this function has already been initiated and the hardware is still signaling that the external latch value is still valid ("extern latch valid"), a further activation should not be carried out and the commando will be declined with an error (the internal handshake communication between NC and IO device is still active). In that case the validity of the external hardware latch would immediately be signaled, although the old latch value would still be present.
4434	17460	Monitoring	"Encoder function not supported" An encoder function has been activated that is currently not released for use, or which is not even implemented.
4435	17461	Monitoring	„Encoder function is already active“ An encoder function can not been activated because this functionality is already active.

Error(Hex)	Error(Dec)	Error Type	Description
4440	17472	Initialization	"Encoder initialization" Encoder has not been initialized. Although the axis has been created, the rest of the initialization has not been performed (1. Initialization of axis I/O, 2. Initialization of axis, 3. Reset axis).
4441	17473	Address	"Axis address" The encoder does not have an axis, or the axis address has not been initialized.
4442	17474	Address	"I/O input structure address" The drive does not have a valid I/O input address in the process image.
4443	17475	Address	"I/O output structure address" The encoder does not have a valid I/O output address in the process image.
4450	17488	Monitoring	"Encoder counter underflow monitoring" The encoder's incremental counter has underflowed.
4451	17489	Monitoring	"Encoder counter overflow monitoring" The encoder's incremental counter has overflowed.
4460	17504	Monitoring	"Minimum Software Position Limit (Axis Start)" While monitoring of the minimum software position limit is active, an axis start has been performed towards a position that lies below the minimum software position limit.
4461	17505	Monitoring	"Maximum Software Position Limit (Axis Start)" While monitoring of the maximum software position limit is active, an axis start has been performed towards a position that lies above the maximum software position limit.
4462	17506	Monitoring	"Minimum Software Position Limit (Positioning Process)" While monitoring of the minimum software position limit is active, the actual position has fallen below the minimum software position limit. In case of servo axes, which are moved continuously, this limit is expanded by the magnitude of the parameterized following error position window.
4463	17507	Monitoring	"Maximum Software Position Limit (Positioning Process)" While monitoring of the maximum software position limit is active, the actual position has exceeded the maximum software position limit. In case of servo axes, which are moved continuously, this limit is expanded by the magnitude of the parameterized following error position window.
4464	17508	Monitoring	„Encoder hardware error“ The drive resp. the encoder system reports a hardware error of the encoder. An optimal error code is displayed in the message of the event log.
4465	17509	Monitoring	„Position initialization error at system start“ At the first initialization of the set position was this for all initialization trials (without over-/under-flow, with underflow and overflow) out of the final position minimum and maximum.
4466	17510	Monitoring	Invalid IO data for more than n subsequent NC cycles (encoder) The axis (encoder) has detected for more than n subsequent NC cycles (NC SAF task) invalid encoder I/O data (e.g. n=3). Typically, regarding an EtherCAT member it is about a Working Counter Error (WcState) what displays that data transfer between I/O device and controller is disturbed. If this error is set for a longer period of time continuously, this situation can lead to losing the axis reference (the "homed" flag will be reset and the encoder will get the state "unreferenced"). Possible reasons for this error: An EtherCAT slave may have left its OP state or there is a too high real time usage or a too high real time jitter.
4467	17511	Monitoring	Invalid Actual Position (Encoder)

Error(Hex)	Error(Dec)	Error Type	Description
			The IO device delivers an invalid actual position (for CANopen/CoE look at bit 13 of encoder state "TxPDO data invalid" or "invalid actual position value").
4468	17512	Monitoring	Invalid IO Input Data (Error Type 1) The monitoring of the "cyclic IO input counter" (2 bit counter) has detected an error. The input data has not been refreshed for at least 3 NC SAF cycles (the 2 bit counter displays a constant value for multiple NC SAF cycles, instead of incrementing by exactly one from cycle to cycle).
4469	17513	Monitoring	Invalid IO Input Data (Error Type 2) The monitoring of the "cyclic IO input counter" (2 bit counter) has detected an error. The quality of input data based on this two bit counter is not sufficient (there is here a simple statistic evaluation that evaluates GOOD cases and BAD cases and in exceeding a special limit value leads to an error).
4470	17520	Monitoring	"SSI transformation fault or not finished" The SSI transformation of the FOX 50 module was faulty for some NC-cycles or did not finished respectively.
44A2	17570	Monitoring	"ENCERR_ADDR_CONTROLLER"
44A3	17571	Monitoring	"ENCERR_INVALID_CONTROLLERTYPE"

6.2.6 Controller Errors

Error(Hex)	Error(Dec)	Error Type	Description
4500	17664	Parameter	"Controller ID not allowed" The value for the controller ID is not allowed, e.g. because it has already been assigned, is less than or equal to zero, or is greater than 255. Value range: [1 ... 255] Unit: 1
4501	17665	Parameter	"Controller type not allowed" The value for the controller type is unacceptable because it is not defined. Type 1: P-controller (position) . . . Type 7: High/low speed controller Type 8: Stepper motor controller Type 9: Sercos controller Value range: [1 ... 8] Unit: 1
4502	17666	Parameter	"Controller operating mode not allowed" The value for the controller operating mode is not allowed. Value range: [1] Unit: 1
4503	17667	Parameter	"Weighting of the velocity pre-control not allowed" The value for the percentage weighting of the velocity pre-control is not allowed. The parameter is pre-set to 1.0 (100%) as standard. Value range: [0.0 ... 1.0] Unit: %
4504	17668	Parameter	"Following error monitoring (position) not allowed" The value for the activation of the following error monitoring is not allowed. Value range: [0, 1] Unit: 1
4505	17669	Parameter	"Following error (velocity) not allowed" The value for the activation of the following error monitoring (velocity) is not allowed. Value range: [0, 1] Unit: 1
4506	17670	Parameter	"Following error window (position) not allowed" The value for the following error window (maximum allowable following error) is not allowed. Value range: [0.0, 10000.0] Unit: e.g. mm

Error(Hex)	Error(Dec)	Error Type	Description
4507	17671	Parameter	"Following error filter time (position) not allowed" The value for the following error filter time (position) is not allowed. Value range: [0.0, 600.0] Unit: s
4508	17672	Parameter	"Following error window (velocity) not allowed" The value for the following error window (velocity) is not allowed. Value range: [0.0, 10000.0] Unit: e.g. m/min
4509	17673	Parameter	"Following error filter time (velocity) not allowed" The value for the following error filter time (velocity) is not allowed. Value range: [0.0, 600.0] Unit: s
450A	17674	Parameter	"Controller Output Limitation" Improper The value for output limitation of the controller at the overall setpoint quantity is improper. The presetting amounts to 0.5 (50 percent). Typically, this parameter is at work if to the motion controller device the velocity interface has been parameterized and the NC performs position control of the position on the controller.
4510	17680	Parameter	"Proportional gain Kv or Kp (controller) not allowed" <i>position</i> The value for the proportional gain (Kv factor or Kp factor) is not allowed. Value range: [0.0, 10000.0] Unit: e.g. mm/s/mm
4511	17681	Parameter	"Integral-action time Tn (controller) not allowed" <i>position</i> The value for the integral-action time is not allowed (I proportion of the PID T1 controller). Value range: [0.0, 60.0] Unit: s
4512	17682	Parameter	"Derivative action time Tv (controller) not allowed" <i>position</i> The value for the derivative action time is not allowed (D proportion of the PID T1 controller). Value range: [0.0, 60.0] Unit: s
4513	17683	Parameter	"Damping time Td (controller) not allowed" <i>position</i> The value for the damping time is not allowed (D proportion of the PID T1 controller). Suggested value: 0.1 * Tv Value range: [0.0, 60.0] Unit: s
4514	17684	Function	"Activation of the automatic offset compensation not allowed" Activation of the automatic offset compensation is only possible for certain types of controller (with no I component).
4515	17685	Parameter	"Additional proportional gain Kv or Kp (controller) not allowed" <i>position</i> The value for the second term of the proportional gain (Kv factor or Kp factor) is not allowed. Value range: [0.0, 10000.0] Unit: e.g. mm/s/mm
4516	17686	Parameter	"Reference velocity for additional proportional gain Kv or Kp (controller) not allowed" <i>position</i> The value for the reference velocity percentage data entry, to which the additional proportional gain is applied, is not allowed. The standard setting for the parameter is 0.5 (50%). Value range: [0.0 ... 1.0] Unit: %
4517	17687	Parameter	"Proportional gain Pa (proportion) not allowed" <i>acceleration</i> The value for the proportional gain (Pa factor) is not allowed. Value range: [0.0, 1000000.0] Unit: s
4518	17688	Parameter	"Proportional gain Kv (velocity controller) not allowed" The value for the proportional gain (Kv factor) is not allowed. Value range: [0.0, 10000.0] Unit: 1

Error(Hex)	Error(Dec)	Error Type	Description
4519	17689	Parameter	“Reset time Tn (velocity controller) not allowed” The value for the integral-action time is not allowed (I proportion of the PID T1 controller).
			Value range: [0.0, 60.0] Unit: s
451A	17690	Parameter	Reserved Reserved, currently not used.
451B	17691	Parameter	Reserved Reserved, currently not used.
451C	17692	Parameter	“Velocity Filter Time” Improper The parameter for velocity filter time in seconds is improper (P-T1 filter). This filter can be used within the NC for filtering an actual velocity or a velocity difference (velocity error = setpoint velocity - actual velocity) in special NC controllers (e.g. within the torque interface).
			Range of values: [0.0, 60.0] Unit: s
451D	17693	Parameter	„Dead zone not allowed“ The value for the dead zone from the position error or the velocity error (system deviation) is not allowed (only for complex controller with velocity or torque interface).
			Value range: [0.0, 10000.0] Unit: mm resp. mm/s
451F	17695	Parameter	“Proportionality Factor Kcp” Improper The parameter for the “proportional factor Kcp” of the slave coupling differential control is improper.
			Range of values: [0.0, 10000.0] Unit: e.g. mm^2/mm
4520	17696	Parameter	”Rate time Tv (velocity controller) not allowed” The value for the derivative action time is not allowed (D proportion of the PID T1 controller).
			Value range: [0.0, 60.0] Unit: s
4521	17697	Parameter	”Damping time Td (velocity controller) not allowed” The value for the damping time is not allowed (D proportion of the PID T1 controller). Suggested value: 0.1 * Tv
			Value range: [0.0, 60.0] Unit: s
4522	17698	Parameter	“Limitation of the I Part” Improper The parameter for limiting the I part of a PI or PID controller is improper. This inner state quantity can be limited in percent (1.0 refers to 100 percent).
			Range of values: [0.0 .. 1.0] Unit: %
4523	17699	Parameter	“Limitation of the D Part” Improper The parameter for limitation of the D part of a PI or PID controller is improper. This inner state quantity may be limited in percent (1.0 refers to 100 percent).
			Range of values: [0.0 .. 1.0] Unit: %
4524	17700	Parameter	Parameter “Switching Off the I Part During Motion” is Improper The boolean parameter for switching off the I part during an active positioning is improper.
			Range of values: [0, 1] Unit: 1
4525	17701	Parameter	Parameter “Filter Time for P-T2 Filter” Improper The time T0 in seconds is as filter time for the velocity controller P-T2 element improper. The filter time has to be smaller than twice the NC-SAF cycle time.

Error(Hex)	Error(Dec)	Error Type	Description
			Range of values: [0.0, 60.0] Unit: s
4526	17702	Parameter	<p>Velocity Observer: “Parameterized Mode” is Improper</p> <p>The parameterized mode (0=OFF, 1=LUNENBERGER) for the special NC controller velocity observer within the torque interface is improper.</p>
			Range of values: [0, 1] Unit: 1
4527	17703	Parameter	<p>Velocity Observer: “Motor Torque Constant Kt or Kf” is Improper</p> <p>The parameter for the motor torque constant K_t (rotational motor) or K_f (linear motor) of the special NC controller velocity observer within the torque interface is improper.</p>
			Range of values: [0.0 .. 100000.0] Unit: Nm/A or N/A
4528	17704	Parameter	<p>Velocity Observer: “Motor Moment of Inertia JM” is Improper</p> <p>The parameter for the motor moment of inertia J_M of the special NC controller velocity observer within the torque interface is improper.</p>
			Range of values: [0.0001 .. 100000.0] Unit: kg cm ²
4529	17705	Parameter	<p>Velocity Observer: “Band Width f0” is Improper</p> <p>The parameter for the band width f_0 of the special NC controller velocity observer within the torque interface is improper. The band width has to be smaller than the reciprocal value of six times the NC cycle time ($f_0 < 1/(6 \cdot T)$).</p>
			Range of values: [0.0 .. 10000.0] Unit: Hz
452A	17706	Parameter	<p>Velocity Observer: “Correction Factor kc” is Improper</p> <p>The parameter for the correction factor k_c of the special NC controller velocity observer within the torque interface is improper. The correction factor k_c implements the relation between current and acceleration or angular acceleration.</p>
			Range of values: [0.0 .. 100.0] Unit: s
452B	17707	Parameter	<p>Velocity Observer: “Time Constant T for First Order Filter” is Improper</p> <p>The time constant T for the first order velocity filter (PID-T_2 or “Lead Lag”) of the specific NC controller velocity observer within the torque interface is improper. The correction factor k_c implements the relation between current and acceleration or angular acceleration.</p>
			Range of values: [0.0 .. 100.0] Unit: s
452C	17708	Parameter	<p>Velocity Observer: “Amplitude Damping d for Second Order Filter” is Improper</p> <p>The high pass/ low pass amplitude damping d_{HP} or d_{TP} for the second order velocity filter (“Bi-Quad”) of the special NC controller velocity observer within the torque interface is improper.</p>
			Range of values: [0.2 .. 10.0] Unit: 1
452D	17709	Parameter	<p>Velocity Observer: “Frequency fHP or Frequency fTP for Filters of Second Order” is Improper</p> <p>The high pass frequency f_{HP} or the low pass frequency f_{TP} for the second order velocity filter (“Bi-Quad”) of the specific NC controller velocity observer within the torque interface is improper.</p>
			Range of values: [0.0, .. 10000.0] Unit: Hz

Error(Hex)	Error(Dec)	Error Type	Description
4540	17728	Initialization	"Controller initialization" Controller has not been initialized. Although the controller has been created, the rest of the initialization has not been performed (1. Initialization of controller, 2. Reset controller).
4541	17729	Address	"Axis address" Controller does not know its axis, or the axis address has not been initialized.
4542	17730	Address	"Drive address" Controller does not know its drive, or the drive address has not been initialized.
4550	17744	Monitoring	"Following error monitoring (position)" With active following error monitoring (position) a following error exceedance has occurred, whose magnitude is greater than the following error window, and whose duration is longer than the parameterized following error filter time.
4551	17745	Monitoring	"Following error monitoring (velocity)" With active following error monitoring (velocity) a velocity following error exceedance has occurred, whose magnitude is greater than the following error window, and whose duration is longer than the parameterized following error filter time.
45A0	17824	Monitoring	"CONTROLERR_RANGE_AREA_ASIDE"
45A1	17825	Monitoring	"CONTROLERR_RANGE_AREA_BSIDE"
45A2	17826	Monitoring	"CONTROLERR_RANGE_QNENN"
45A3	17827	Monitoring	"CONTROLERR_RANGE_PNENN"
45A4	17828	Monitoring	"CONTROLERR_RANGE_AXISIDPRESPO"

6.2.7 Drive Errors

Error(hex)	Error(dec)	Error Type	Description
4600	17920	Parameter	"Drive ID not allowed" The value for the drive ID is not allowed, e.g. because it has already been assigned, is less than or equal to zero, or is greater than 255.
			Value range: [1 ... 255] Unit: 1
4601	17921	Parameter	'Drive type impermissible' The value for the drive type is impermissible, since it is not defined.
			Value range: [1, 20] Unit: 1
4602	17922	Parameter	'Drive operating mode impermissible' The value for the drive operating mode is impermissible (mode 1: standard).
			Value range: [1] Unit: 1
4603	17923	Parameter	"Motor polarity inverted?" The flag for the motor polarity is not allowed. Flag 0: Positive motor polarity flag 1: Negative motor polarity
			Value range: [0, 1] Unit: 1
4604	17924	Parameter	'Drift compensation/speed offset (DAC offset)' The value for the drift compensation (DAC offset) is impermissible.
			Value range: [-100.0, 100.0] Unit: e.g. m/min
4605	17925	Parameter	'Reference speed (velocity pre-control)' The value for the reference speed (also called velocity pilot control) is impermissible.
			Value range: [0.0, 10000.0] Unit: e.g. m/min
4606	17926	Parameter	'Reference output in percent' The value for the reference output in percent is impermissible. The value 1.0 (100 %) usually corresponds to a voltage of 10.0 V.
			Value range: [0.0, 5.0] Unit: %

Error(hex)	Error(dec)	Error Type	Description
4607	17927	Parameter	'Quadrant compensation factor' The value for the quadrant compensation factor is impermissible.
			Value range: [0.0, 100.0] Unit: 1
4608	17928	Parameter	'Velocity reference point' The value for the velocity reference point in percent is impermissible. The value 1.0 corresponds to 100 percent.
			Value range: [0.01, 1.0] Unit: %
4609	17929	Parameter	'Output reference point' The value for the output reference point in percent is impermissible. The value 1.0 corresponds to 100 percent.
			Value range: [0.01, 1.0] Unit: %

Error(hex)	Error(dec)	Error Type	Description
460A	17930	Parameter	'Minimum or maximum output limits (output limitation)' The value for the minimum and/or maximum output limit is impermissible. This will happen if the range of values is exceeded, the maximum limit is smaller than the minimum limit, or the distance between the minimum and maximum limits is zero. The minimum limit is initially set to -1.0 (-100 percent) and the maximum limit to 1.0 (100 percent).
			Value range: [-1.0, 1.0] Unit: %
460B	17931	Parameter	Parameter "Maximum Value for Output" is Improper The value for the maximum number of output digits of motion controllers (maximum output value) is improper. According to the used interface (e.g. position, velocity or torque/current). Regarding a velocity interface it is often about a signed 16 bit output value (± 32767).
			Range of values: [0x000000FF .. 0xFFFFFFFF] Unit: INC or Digits
460C	17932	Parameter	Parameter "Internal Drive Control Word" is Improper The value as Internal Drive Control Word for the NC is improper. In this control word information from the system manager to the NC is contained what is evaluated at the TC start of the NC.
			Range of values: [>0] Unit: 1
460D	17933	Parameter	Parameter "Internal Timer for RESET Behavior of Motion Controller" is Improper The special parameter that influences the internal timing behavior between the NC motion controller and the IO motion controller is improper.
			Range of values: [>5] Unit: 1 (NC SAF Cycles)
460E	17934	Parameter	Parameter "Master Motion Controller ID" is Improper The parameter "master motion controller ID" is improper for a further NC motion controller in slave mode. An additional NC motion controller in slave mode can be used if this usage is about the same motion controller device on that different NC information for e.g. different operation modes are joined (e.g. velocity mode and torque mode). Note: This parameter is not accessible by the user directly, but can be influenced indirectly by the configuration of additional NC motion controllers below the NC axis.
			Range of values: [0 .. 255] Unit: 1

Error(hex)	Error(dec)	Error Type	Description
460F	17935	Parameter	'Drive torque output scaling impermissible' The value is impermissible as drive torque output scaling (rotary motor) or as force output scaling (linear motor).
			Value range: [0, 1000000] Unit: 1
4610	17936	Parameter	„Drive velocity output scaling is not allowed“ The value for the drive velocity output scaling is not allowed.
			Value range: [0, 1000000] Unit: 1
4611	17937	Parameter	'Profi Drive DSC proportional gain Kpc (controller) impermissible' <i>Positions</i> The value for the Profi Drive DSC position control gain (Kpc factor) is impermissible.
			Value range: [0, 0xFFFFF] Unit: 0.001 * 1/s
4612	17938	Parameter	'Table ID is impermissible' The value for the table ID is impermissible.
			Value range: [0, 255] Unit: 1
4613	17939	Parameter	'Table interpolation type is impermissible' The value is impermissible as the table interpolation type.
			Value range: 0 (LINEAR), 2 (SPLINE) Unit: 1
4614	17940	Parameter	'Output offset in percent is impermissible' The value is impermissible as an output offset in percent (+/- 1.0).
			Value range: [-1.0, 1.0] Unit: %
4615	17941	Parameter	'Profi Drive DSC scaling for calculation of "Xerr" (controller) impermissible' <i>Positions</i> : the value is impermissible as Profi Drive DSC scaling for the calculation of 'Xerr'.
			Value range: [0, 1000000] Unit: 1
4616	17942	Parameter	'Drive acceleration output scaling impermissible' The value is impermissible as drive acceleration/deceleration output scaling.
			Value range: [0, 1000000] Unit: 1
4617	17943	Parameter	'Drive position output scaling impermissible' The value is impermissible as drive position output scaling.
			Value range: [0, 1000000] Unit: 1
4618	17944	Parameter	Parameter "Dead Time Compensation Mode" (Motion Controller) is Invalid The parameter for the mode of dead time compensation of NC motion controllers is invalid (OFF, ON with velocity, ON with velocity and acceleration).
			Range of values: [0, 1, 2] Unit: 1
4619	17945	Parameter	Parameter "Control Bits of Dead Time Compensation" (Motion Controller) is Invalid The parameter for "control bits of dead time compensation" of NC motion controllers is invalid (e.g. relative or absolute time interpretation).
			Range of values: [>0] Unit: 1
461A	17946	Parameter	Parameter "Time Shift of Dead Time Compensation" (Motion Controller) is Invalid The parameter for the time shift of dead time compensation (time shift in nanoseconds) of the NC motion controller is invalid.
			Range of values: [-1.0E9 .. 1.0E9] Unit: ns

Error(hex)	Error(dec)	Error Type	Description
461B	17947	Parameter	Parameter “Output Delay (Velocity)” is Invalid The parameter for an optional output delay within the velocity interface to the motion controller is invalid (output delay (velocity)). The maximum permitted delay time has to be smaller than 100 times the NC SAF cycle time.
			Range of values: [0.0 .. 0.1] Unit: s
461C	17948	Parameter	‘Drive filter type impermissible for command variable filter for the output position’ The value is impermissible as a drive filter type for the smoothing of the output position (command variable filter for the setpoint position).
			Value range: [0, 2] Unit: 1
461D	17949	Parameter	‘Drive filter time impermissible for command variable filter for the output position’ The value is impermissible as a drive filter time for the smoothing of the output position (command variable filter for the setpoint position).
			Value range: [0.0, 1.0] Unit: s
461E	17950	Parameter	‘Drive filter order impermissible for command variable filter for the output position’ The value is impermissible as a drive filter order (P-Tn) for the smoothing of the output position (command variable filter for the setpoint position).
			Value range: [0, 10] Unit: 1
4620	17952	Parameter	‘Bit mask for stepper motor cycle impermissible’ A value of the different stepper motor masks is impermissible for the respective cycle.
			Value range: [0, 255] Unit: 1
4621	17953	Parameter	‘Bit mask for stepper motor holding current impermissible’ The value for the stepper motor holding mask is impermissible.
			Value range: [0, 255] Unit: 1
4622	17954	Parameter	‘Scaling factor for actual torque (actual current) impermissible’ The value is impermissible as a scaling factor for the actual torque (or actual current).
			Value range: [0, 1E+30] Unit:
4623	17955	Parameter	‘Filter time for actual torque is impermissible’ The value is impermissible as a filter time for the actual torque (or the actual current) (P-T1 filter).
			Value range: [0.0, 60.0] Unit: s
4624	17956	Parameter	‘Filter time for the temporal derivation of the actual torque is impermissible’ The value is impermissible as a filter time for the temporal derivation of the actual torque (or actual current) (P-T1 filter).
			Value range: [0.0, 60.0] Unit: s

Error(hex)	Error(dec)	Error Type	Description
4625	17957	Parameter	<p>Parameter for the “Motion Controller Operation Mode” is Invalid</p> <p>The parameter for the motion controller operation mode (position mode, velocity mode, torque mode, ...) is invalid. Possibly, an NC operation mode switching has been tried or at TC system start has been tried to activate a preconfigured operation mode.</p> <p>Annotations: The generic operation modes defined within the NC are realized by the NC motion controller specifically, i.e. in particular for the protocols SERCOS/ SoE and CANopen/ CoE (DS402). In this connection, protocol specific, motion controller specific or even customer specific peculiarities have to be obeyed (e.g. regarding SERCOS/ SoE merely in the SERCOS parameter range S-0-0032 to S-0-0035 predefined operation modes can be activated at runtime). Furthermore, not every generic NC operation mode can be converted into a motion controller specific operation mode (here gaps within the specification may exist).</p> <p>The generic NC operation mode 0 forms a special case. This value is used as a mark to activate an NC default operation mode (as long as this mark is known to the NC).</p> <p>Range of values: [0, >=1] Unit: 1</p>
4626	17958	Monitoring	<p>Motion Controller Functionality is Not Supported</p> <p>A motion controller functionality has been set off that has not been released for usage or has not been implemented (e.g. writing or reading of a motion controller mode that is not supported by certain motion controllers). It is also possible that this functionality is merely not supported at times (e.g. because the motion controller device resides in error state or a motion controller enable is missing).</p>
4627	17959	Function	<p>DRIVEOPERATIONMODEBUSY. The activation of the motion controller controlling mode has failed because another object with OI... uses this interface already.</p>
4628	17960	Monitoring	<p>Motion Controller Operation Mode Switching has not been configured or the desired motion controller operation mode cannot be found</p> <p>There has not any motion controller operation mode switching been configured and thus no reading or writing of a motion controller operation mode is possible. Or the desired motion control operation mode has not been found in the list of the predefined motion controller operation modes (e.g. for SoE/ SERCOS).</p> <p>Annotation for CoE motion controllers: The reading or writing of the CoE Motion Control Operation Mode is merely possible if the CoE objects 0x6060 Modes Of Operation and 0x6061 Modes Of Operation Display can be found in the cyclic process data (PDO list) and a valid default operation mode has been configured.</p> <p>Annotation for SoE motion controllers: The reading or writing of the current SoE Motion Controller Operation Mode is merely possible if this operation mode has been predefined in one of the SoE Parameters S-0-0032 to S-0-0035.</p>
<p>0x4630 ... 0x463F: Error codes are reserved for external motion controller errors (e.g. stepper motor terminal or function block MC_PowerStepper).</p>			

Error(hex)	Error(dec)	Error Type	Description
4630	17968	Monitoring	'Overtemperature' Overtemperature was detected or reported in the drive or terminal.
4631	17969	Monitoring	'Undervoltage' Undervoltage was detected or reported in the drive or terminal.
4632	17970	Monitoring	'Wire break in phase A' A wire break in phase A was detected or reported in the drive or terminal.
4633	17971	Monitoring	'Wire break in phase B' A wire break in phase B was detected or reported in the drive or terminal.
4634	17972	Monitoring	'Overcurrent in phase A' Overcurrent was detected or reported in phase A in the drive or terminal.
4635	17973	Monitoring	'Overcurrent in phase B' Overcurrent was detected or reported in phase B in the drive or terminal.
4636	17974	Monitoring	'Torque overload (stall)' A torque overload (stall) was detected or reported in the drive or terminal.
4640	17984	Initialization	'Drive initialization' Drive has not been initialized. Although the drive has been created, the rest of the initialization has not been performed (1. Initialization of drive I/O, 2. Initialization of drive, 3. Reset drive).
4641	17985	Address	'Axis address' Drive does not know its axis, or the axis address has not been initialized.
4642	17986	Address	'Address IO input structure' Drive has no valid IO input address in the process image.
4643	17987	Address	'Address IO output structure' Drive has no valid IO output address in the process image.
4650	18000	Monitoring	'Drive hardware not ready to operate' The drive hardware is not ready for operation. The following are possible causes: - the drive is in the error state (hardware error) - the drive is in the start-up phase (e.g. after an axis reset that was preceded by a hardware error) - the drive is missing the controller enable (ENABLE) Note: The time required for "booting" a drive after a hardware fault can amount to several seconds.
4651	18001	Monitoring	Error in the cyclic communication of the drive (Life Counter). Reasons for this could be an interrupted fieldbus or a drive that is in the error state.
4652	18002	Monitoring	'Changing the table ID when active controller enable is impermissible' . Changing (deselecting, selecting) the characteristic curve table ID is not permissible when the controller enable for the axis is active.
4655	18005	Monitoring	'Invalid IO data for more than 'n' continuous NC cycles' The axis (encoder or drive) has detected invalid IO data (e.g. n=3) for more than 'n' continuous NC cycles (NC SAF task). EtherCAT fieldbus: 'working counter error ('WCState')' As a result it is possible that the encoder referencing flag will be reset to FALSE (i.e. the encoder is given the status 'unreferenced'). Lightbus fieldbus: 'CDL state error ('CdIState')' As a result it is possible that the encoder calibration flag will set to FALSE (that means uncalibrated).

6.2.8 Table Errors

Error(Hex)	Error(Dec)	Error Type	Description
4A00	18944	Parameter	"Table ID not allowed" The value for the table ID is not allowed, e.g. because it has already been assigned, is less than or equal to zero, or is greater than 255.
			Value range: [1 ... 255] Unit: 1
4A01	18945	Parameter	"Table type not allowed" The value for the table type is unacceptable because it is not defined.
			Value range: [1] Unit: 1
4A02	18946	Parameter	"Number of lines in the table not allowed" The value of the number of lines in the table is not allowed, because, for example, it is smaller than two at linear interpolation and smaller than four at spline interpolation.
			Value range: [2, 0xFFFF] Unit: 1
4A03	18947	Parameter	"Number of columns in the table is not allowed" The value of the number of columns in the table is not allowed, because, for example, it is less than or equal to zero (depends upon the type of table or slave).
			Value range: [1, 0xFFFF] Unit: 1
4A04	18948	Parameter	"Step size (position delta) not allowed" The value for the step size between two lines (position delta) is not allowed, because, for example, it is less than or equal to zero.
			Value range: [0.001, 1.0E+6] Unit: e.g. mm
4A05	18949	Parameter	"Period not allowed" The value for the period is not allowed, because, for example, it is less than or equal to zero.
			Value range: [0.001, 1.0E+9] Unit: e.g. mm
4A06	18950	Parameter	"Table is not monotonic" The value for the step size is not allowed, because, for example, it is less than or equal to zero.
4A07	18951	Initialization	„Table sub type is not allowed“ The value for the table sub type is not allowed or otherwise the table class (slave type) do not match up to the table main type. Table sub type: (1) equidistant linear position table, (2) equidistant cyclic position table, (3) none equidistant linear position table, (4) none equidistant cyclic position table
			Value range: [1, 4] Unit: 1
4A08	18952	Initialization	„Table interpolation type is not allowed“ The value for the table interpolation type is allowed. Table interpolation type: (0) linear-interpolation, (1) 4-point-interpolation, (2) spline-interpolation
			Value range: [0, 2] Unit: 1

Error(Hex)	Error(Dec)	Error Type	Description
4A09	18953	Initialization	"Incorrect table main type" The table main type is unknown or otherwise the table class (slave type) do not match up to the table main type. Table main type: (1) camming table, (2) characteristic table, (3) 'motion function' table (MF)
4A10	18960	Initialization	"Table initialization" Table has not been initialized. Although the table has been created, the rest of the initialization has not been performed. For instance, the number of lines or columns may be less than or equal to zero.
4A11	18961	Initialization	"Not enough memory" Table could not be created, since there is not enough memory.

Error(Hex)	Error(Dec)	Error Type	Description
4A12	18962	Function	"Function not executed, function not available" The function has not been implemented, or cannot be executed, for the present type of table.
4A13	18963	Function	"Line index not allowed" The start line index or the stop line index to be used for read or write access to the table is not allowed. For instance, the line index may be greater than the total number of lines in the table.
4A14	18964	Function	"Column index not allowed" The start column index or the stop column index to be used for read or write access to the table is not allowed. For instance, the column index may be greater than the total number of columns in the table.
4A15	18965	Function	"Number of lines not allowed" The number of lines to be read from or written to the table is not allowed. The number of lines must be an integer multiple of the number of elements in a line (n * number of columns).
4A16	18966	Function	"Number of columns not allowed" The number of columns to be read from or written to the table is not allowed. The number of columns must be an integer multiple of the number of elements in a column (n * number of lines).
4A17	18967	Function	"Error in scaling or in range entry" The entries in the table header are inconsistent, e.g. the validity range is empty. If the error is generated during the run time it is a run time error and stops the master/slave group.
4A18	18968	Function	"Multi table slave out of range" The slave master position is outside the table values for the master. The error is a run-time error, and stops the master/slave group.
4A19	18969	Function	"Solo table underflow" The slave master position is outside the table values for the master. The master value of the equidistant table, to be processed linearly, lies under the first table value. The error is a run-time error, and stops the master/slave group.
4A1A	18970	Function	"Solo table overflow" The slave master position is outside the table values for the master. The master value of the equidistant table, to be processed linearly, lies above the first table value. The error is a run-time error, and stops the master/slave group.
4A1B	18971	Parameter	"Incorrect execution mode" The cyclic execution mode can only be "true" or "false".
4A1C	18972	Parameter	"Impermissible parameter" The Fifo parameter is not allowed.
4A1D	18973	Parameter	"Fifo is empty" The Fifo of the external generator is empty. This can signify end of track or a run time error.
4A1E	18974	Parameter	"Fifo is full" The Fifo of the external generator is full. It is the user's task to continue to attempt to fill the Fifo with the rejected values.
4A1F	18975	Parameter	„Point-Index of Motion Function invalid“ The point index of a Motion Function Point of a Function Table is invalid. First the point index has to be larger than zero and second it has to be numerical continuously for one column in the Motion Function Table (e.g. 1,2,3,... or 10,11,12,...). Remark: The point index is not online-changeable but must be constant.
4A20	18976	Initialization	„No diagonalization of matrix“ The spline can not be calculated. The master positions are not correct.
4A21	18977	Initialization	„Number of spline points to less“ The number of points of a cubic spline has to be greater than two.

Error(Hex)	Error(Dec)	Error Type	Description
4A22	18978	Initialization	„ Fifo must not be overwritten “ Fifo must not be overwritten since then the active line would be overwritten. It is the task of the user to secure that the active line is not modified.
4A23	18979	Function	„ Insufficient number of Motion Function points “ The number of valid Motion Function points is less than two. Either the entire number of points is too low or the point type of many points is set to <i>Ignore Point</i> .
4A25	18981	Initialization	“ Table master start position is not allowed ” A periodic position table must start with a master position zero. A Motion Function (MF) table can start at a position greater than zero but less than the cam period.

6.2.9 NC-PLC Errors

Error(Hex)	Error(dec)	Error type	Description
4B00	19200	Parameter	"Axis was stopped" The axis was stopped during travel to the target position. The axis may have been stopped with a PLC command via ADS, a call via AXFNC, or by the System Manager.
4B01	19201	Parameter	"Axis cannot be started" The axis cannot be started because: <ul style="list-style-type: none"> • the axis is in error status, • the axis is executing another command, • the axis is in protected mode, • the axis is not ready for operation.
4B02	19202	Parameter	"Control mode not permitted" No target position control, and no position range control.
4B03	19203	Parameter	"Axis is not moving" The position and velocity can only be restarted while the axis is physically in motion.
4B04	19204	Parameter	"Invalid mode" Examples: Invalid <i>Direction</i> with <code>MC_MoveModulo</code> . Inactive axis parameter <i>Position correction</i> with <code>MC_BacklashCompensation</code> .
4B05	19205	Parameter	"Command not permitted" <ul style="list-style-type: none"> • Continuous motion in an unspecified direction • Read/Write parameters: type mismatch
4B06	19206	Parameter	"Parameter incorrect" <ul style="list-style-type: none"> • Incorrect override: > 100% or < 0% • Incorrect gear ratio: <code>RatioDenominator</code> = 0
4B07	19207	Parameter	"Timeout axis function block" After positioning, all "MC_Move..." blocks check whether positioning was completed successfully. In the simplest case, the "AxisHasJob" flag of the NC axis is checked, which initially signifies that positioning was logically completed. Depending on the parameterization of the NC axis, further checks (quality criteria) are used: <ul style="list-style-type: none"> • "Position range monitoring" If position range monitoring is active, the system waits for feedback from the NC. After positioning, the axis must be within the specified positioning range window. If necessary, the position controller ensures that the

Error(Hex)	Error(dec)	Error type	Description
			<p>axis is moved to the target position. If the position controller is switched off (Kv=0) or weak, the target may not be reached.</p> <ul style="list-style-type: none"> "Target position monitoring" If target position monitoring is active, the system waits for feedback from the NC. After positioning, the axis must be within the specified target position window for at least the specified time. If necessary, the position controller ensures that the axis is moved to the target position. If the position controller is switched off (Kv=0) or weak, the target may not be reached. Floating position control may lead to the axis oscillating around the window but not remaining inside the window. <p>If the axis is logically at the target position (logical standstill) but the parameterized position window has not been reached, monitoring of the above-mentioned NC feedback is aborted with error 19207 (0x4B07) after a constant timeout of 6 seconds.</p>
4B08	19208	Parameter	"Axis is in protected mode" The axis is in protected mode (e.g., coupled) and cannot be moved.
4B09	19209	Parameter	"Axis is not ready" The axis is not ready and cannot be moved.
4B0A	19210	Parameter	"Error during referencing" Referencing (homing) of the axis could not be started or was not successful.
4B0B	19211	Parameter	"Incorrect definition of the trigger input" The definition of the trigger signal for function block MC_TouchProbe is incorrect. The defined encoder-ID, the trigger signal or the trigger edge are invalid.
4B0C	19212	Function	"Position latch was disabled" The function block MC_TouchProbe has detected that a measuring probe cycle it had started was disabled. The reason may be an axis reset, for example.
4B0D	19213	Function	"NC status feedback timeout" A function was successfully sent from the PLC to the NC. An expected feedback in the axis status word has not arrived.
4B0E	19214	Function	"Additional product not installed" The function is available as an additional product but is not installed on the system.
4B0F	19215	Function	"No NC Cycle Counter Update" – The NcToPlc Interface or the NC Cycle Counter in the NcToPlc Interface was not updated.
Error numbers 0x4B10 .. 0x4B2F are used in the <i>TwinCAT NCI</i> context:			
4B10	19216	Function	"M-function query missing" This error occurs if the M-function was confirmed, but the request bit was not set.
4B11	19217	Parameter	"Zero shift index is outside the range" The index of the zero shift is invalid.
4B12	19218	Parameter	"R-parameter index or size is invalid" This error occurs if the R-parameters are written or read but the index or size are outside the range.
4B13	19219	Parameter	"Index for tool description is invalid"
4B14	19220	Function	"Version of the cyclic channel interface does not match the requested function or the function block" This error occurs if an older TwinCAT version is used to call new functions of a later TcNci.lib version.

Error(Hex)	Error(dec)	Error type	Description
4B15	19221	Function	"Channel is not ready for the requested function" The requested function cannot be executed, because the channel is in the wrong state. This error occurs during reverse travel, for example, if the axis was not stopped with ItpEStop first.
4B16	19222	Function	"Requested function is not activated" The requested function requires explicit activation.
4B17	19223	Function	"Axis is already in another group" The axis has already been added to another group.
4B18	19224	Function	"Block search could not be executed successfully" The block search has failed. Possible causes: <ul style="list-style-type: none"> Invalid block number
4B19	19225	Parameter	"Invalid block search parameter" This error occurs if the FB ItpBlocksearch is called with invalid parameters (e.g., E_ItpDryRunMode, E_ItpBlockSearchMode)
4B20	19232	Function	"Cannot add all axes" This error occurs if an auxiliary axis is to be added to an interpolation group, but the function fails. It is likely that a preceding instruction of an auxiliary axis was skipped.
Error numbers 0x4B30 .. 0x4B3F are used in the TcMcCam library (MC_NC_TableErrorCodes):			
4B30	19248	Parameter	"Pointer is invalid" A pointer to a data structure is invalid, e.g., Null <ul style="list-style-type: none"> Data structure MC_CAM_REF was not initialized
4B31	19249	Parameter	"Memory size invalid" The specification of the memory size (SIZE) for a data structure is invalid. <ul style="list-style-type: none"> The value of the size parameter is 0 or less than the size of one element of the addressed data structure. The value of the size parameter is less than the requested amount of data. The value of the size parameter does not match other parameters as number of points, number of rows or number of columns.
4B32	19250	Parameter	"Cam table ID is invalid" The ID of a cam table is not between 1 and 255.
4B33	19251	Parameter	"Point ID is invalid" The ID of a point (sampling point) of a motion function is less than 1.
4B34	19252	Parameter	"Number of points is invalid" The number of points (sampling points) of a cam plate to be read or written is less than 1.
4B35	19253	Parameter	"MC table type is invalid" The type of a cam plate does not match the definition <i>MC_TableType</i> .
4B36	19254	Parameter	"Number of rows invalid" The number of rows (sampling points) of a cam table is less than 1.
4B37	19255	Parameter	"Number of columns invalid" The number of columns of a cam table is invalid. <ul style="list-style-type: none"> The number of columns of a motion function is not equal 1 The number of columns of a standard cam table is not equal 2 The number of columns does not match another parameter (ValueSelectMask)
4B38	19256	Parameter	"Step size invalid" . The increment for the interpolation is invalid, e.g., less than or equal to zero.

Error(Hex)	Error(dec)	Error type	Description
Error numbers 0x4B0F, 0x4B40 .. 0x4B4F are used in several libraries (TcNc-Lib / Tc2_MC2_XFC-Lib):			
4B40	19264	Monitoring	"Terminal type not supported" The terminal used is not supported by this function block.
4B41	19265	Monitoring	"Register read/write error" This error implies a validity error.
4B42	19266	Monitoring	"Axis is enabled" The axis is enabled but should not be enabled for this process.
4B43	19267	Parameter	"Incorrect size of the compensation table" The specified table size (in bytes) does not match the actual size
4B44	19268	Parameter	The minimum/maximum position in the compensation table does not match the position in the table description (ST_CompensationDesc)
4B45	19269	Parameter	"Not implemented" The requested function is not implemented in this combination
4B46	19270	Parameter	"Window not in the specified modulo range" The parameterized min or max position is not in the specified modulo range
4B47	19271	Monitoring	"Buffer overflow" The number of events has led to an overflow of the buffer and not all events could be acquired.
Error numbers 0x4B50 .. 0x4B5F are used in the TcRemoteSyn-Lib:			
Error numbers 0x4B60 .. 0x4B6F are used in the TcMc2-Lib in the buffered commands context:			
4B60	19296	Monitoring	"Motion command did not become active" A motion command has been started and has been buffered and confirmed by the NC. Nevertheless, the motion command did not become active (possibly due to a terminating condition or an internal NC error).
4B61	19297	Monitoring	"Motion command could not be monitored by the PLC" A motion command has been started and has been buffered and confirmed by the NC. The PLC has not been able to monitor the execution of this command and the execution status is unclear since the NC is already executing a more recent command. The execution state is unclear. This error may come up with very short buffered motion commands which are executed during one PLC cycle.
4B62	19298	Monitoring	"Buffered command was terminated with an error" A buffered command was terminated with an error. The error number is not available, because a new command is already being executed.
4B63	19299	Monitoring	"Buffered command was completed without feedback" A buffered command was completed but there was no feedback to indicate success or failure.
4B64	19300	Monitoring	" 'BufferMode' is not supported by the command" The 'BufferMode' is not supported by this command.
4B65	19301	Monitoring	"Command number is zero" The command number for queued commands managed by the system unexpectedly has the value 0.
4B66	19302	Monitoring	"Function block was not called cyclically" The function block was not called cyclically. The command execution could not be monitored by the PLC, because the NC was already executing a subsequent command. The execution state is unclear.
Error numbers 0x4B70 .. 0x4B8F are used in the TcPlcInterpolation-Lib:			

Error(Hex)	Error(dec)	Error type	Description
4B71	19313	Parameter	"Invalid NCI entry type". The FB FB_NciFeedTablePreparation was called with an unknown nEntryType.
4B72	19314	Function	"NCI feed table full" The table is full, and the entry is therefore not accepted. Remedy: Transfer the context of the table with FB_NciFeedTable to the NC kernel. If bFeedingDone = TRUE, the table can be reset in FB_NciFeedTablePreparation with bResetTable and then filled with new entries.
4B73	19315	Function	internal error
4B74	19316	Parameter	"ST_NciTangentialFollowingDesc: Tangential axis is not an auxiliary axis" In the entry for the tangential following, a tangential axis was named that is not an auxiliary axis.
4B75	19317	Parameter	ST_NciTangentialFollowingDesc: nPathAxis1 or nPathAxis2 is not a path axis. It is therefore not possible to determine the plane.
4B76	19318	Parameter	ST_NciTangentialFollowingDesc: nPathAxis1 and nPathAxis2 are the same. It is therefore not possible to determine the plane.
4B77	19319	Parameter	ST_NciGeoCirclePlane: Circle incorrectly parameterized
4B78	19320	Function	Internal error during calculation of tangential following
4B79	19321	Monitoring	Tangential following: Monitoring of the deviation angle was activated during activation of tangential following (E_TfErrorOnCritical1), and an excessively large deviation angle was detected in the current segment.
4B7A	19322	Function	not implemented
4B7B	19323	Parameter	Tangential following: the radius of the current arc is too small
4B7C	19324	Parameter	FB_NciFeedTablePreparation: pEntry is NULL
4B7D	19325	Parameter	FB_NciFeedTablePreparation: the specified nEntryType does not match the structure type
4B7E	19326	Parameter	ST_NciMFuncFast and ST_NciMFuncHsk: the requested M-function is not between 0 and 159
4B7F	19327	Parameter	ST_NciDynOvr: the requested value for the dynamic override is not between 0.01 and 1
4B80	19328	Parameter	ST_NciVertexSmoothing: invalid parameter. This error is generated if a negative smoothing radius or an unknown smoothing type is encountered.
4B81	19329	Parameter	FB_NciFeedTablePreparation: The requested velocity is not in the valid range
4B82	19330	Parameter	ST_Nci*: invalid parameter
Error numbers 0x4B90 .. 0x4B9F are used in the Tc3_MC2_AdvancedHoming-Lib(PLCopen Part 5: Homing Procedures):			
4B90	19344	Parameter	Determined drive type is not supported
4B91	19345	Parameter	Direction is impermissible
4B92	19346		SwitchMode is impermissible
4B93	19347		Mode for the parameter handling is impermissible
4B94	19348		Parameterization of the torque limits is inconsistent
4B95	19349		Parameterization of the position lag limit is impermissible (<=0).
4B96	19350		Parameterization of the distance limit is impermissible (<0)

Error(Hex)	Error(dec)	Error type	Description
4B97	19351		An attempt was made to back up parameters again, although they have already been backed up.
4B98	19352		An attempt was made to restore parameters, although none have been backed up.
4B9F	19359		The abortion of a homing has failed.
Error numbers 0x4BA0 .. 0x4BAF are used in the <i>TcNcKinematicTransformation-Lib</i>:			
4BA0	19360	Function	KinGroup error: the kinematic group is in an error state. This error may occur if the kinematic group is in an error state or an unexpected state when it is called (e.g., simultaneous call via several FB instances).
4BA1	19361	Function	KinGroup timeout: timeout during call of a kinematic block
Error numbers 0x4BB0 .. 0x4BBF are used in the <i>Tc2_MC2_Drive-Lib</i>:			
4BB0	19376	Function	The current axis position or the axis position resulting from the new position offset exceeds the valid range of values.
4BB1	19377	Function	The new position offset exceeds the valid range of values [AX5000: 2 ³¹].
4BB2	19378	Function	The current axis position or the axis position resulting from the new position offset falls below the valid range of values.
4BB3	19379	Function	The new position offset falls below the valid range of values [AX5000: -2 ³¹].
4BB4	19380	Function	The activated feedback and/or storage location (AX5000: P-0-0275) differ from the parameterization on the function block.
4BB5	19381	Function	Reinitialization of the actual NC position has failed, e.g., reference system = "ABSOLUTE (with single overflow)" & software end position monitoring is disabled.
4BB6	19382	Function	The command to set or delete a position offset was rejected without feedback data, e.g., if the drive controller's firmware does not support the corresponding command.
4BB7	19383	Function	The command to set or delete a position offset was rejected with feedback data. The information in the feedback data may contain further information about the cause. e.g., if the drive controller's firmware does not support the corresponding command.
4BB8	19384	Function	A firmware version >= 19 is required for the servo terminal.
4BB9	19385	Function	The modulo settings on the drive controller and NC are different.
Error numbers 0x4BC0 .. 0x4BCF are used in the <i>Tc3_DriveMotionControl-Lib</i>:			
4BC2	19394		The new position offset exceeds the valid value range.
4BC3	19395		I/O data are invalid or the terminal is in an error state.

6.2.10 Kinematic Transformation

Error(Hex)	Error(Dec)	Error Type	Description
4C00	19456		Transformation failed.
4C01	19457		Ambiguous answer. The answer of the transformation is not explicit.

Error(Hex)	Error(Dec)	Error Type	Description
4C02	19458		Invalid axis position: The transformation can not be calculated with the current position data. Possible causes: <ul style="list-style-type: none"> The position is outside the working area of the kinematics
4C03	19459	Configuration	Invalid dimension: The dimension of the parameterized input parameter does not match the dimension expected by the kinematic object. Possible causes: <ul style="list-style-type: none"> Too many position values are supplied for this configuration. Check the number of parameterized axes.
4C04	19460		NCERR_KINTRAF0_REGISTRATION
4C05	19461	Internal	Newton iteration failed: The Newton iteration does not converge.
4C06	19462	Internal	Jacobi matrix cannot be inverted
4C07	19463	Configuration	Invalid cascade: This kinematic configuration is not permitted.
4C08	19464	Programming	Singularity: The machine configuration results in singular axis velocities.
4C0B	19467	Internal	No metainfo: Metainfo pointer is null.
4C13	19475	Internal	NCERR_RBTFRAME_INVALIDWCSTOMCS The employed <code>WcsToMcs</code> component leads to positions that the selected kinematics cannot adopt to. Tailoring the <code>WcsToMcs</code> parameters is required.
4C20	19488	Internal	Transformation failed: Call of extended kinematic model failed.
4C30	19504	Programming	Invalid input frame: Programmed Cartesian position cannot be reached in the ACS configuration.
4C50	19536	Internal	Invalid Offset: Access violation within the observer detected.

6.2.11 Bode Return Codes

The following bode plot specific error codes are used in the bode plot server:

Code Hex	Code Dec	Symbol	Description
0x8100	33024	INTERNAL	Internal error
0x8101	33025	NOTINITIALIZED	Not initialized (e.g. no nc axis)
0x8102	33026	INVALIDPARAM	Invalid parameter
0x8103	33027	INVALIDOFFSET	Invalid index offset
0x8104	33028	INVALIDSIZE	Invalid parameter size
0x8105	33029	INVALIDSTARTPARAM	Invalid start parameter (set point generator)
0x8106	33030	NOTSUPPORTED	Not supported
0x8107	33031	AXISNOTENABLED	Nc axis not enabled
0x8108	33032	AXISINERRORSTATE	Nc axis in error state
0x8109	33033	DRIVEINERRORSTATE	IO drive in error state
0x810A	33034	AXISANDDRIVEINERROR-STATE	Nc axis AND IO drive in error state

0x810B	33035	INVALIDDRIVEOPMODE	Invalid drive operation mode active or requested (no bode plot mode)
0x810C	33036	INVALIDCONTEXT	Invalid context for this command (mandatory task or windows context needed)
0x810D	33037	NOAXISINTERFACE	Missing TCom axis interface (axis null pointer). There is no connection to the NC axis. Either no axis (or axis ID) has been parameterized, or the parameterized axis does not exist.
0x810E	33038	INPUTCYCLECOUNTER	Invalid input cycle counter from IO drive (e.g. frozen). The cyclic drive data are backed up by an 'InputCycleCounter' during the bode plot recording. This allows firstly the detection of an unexpected communication loss (keyword: LifeCounter) and secondly a check for temporal data consistency to be performed. Sample 1: This error can occur if the cycle time of the calling task is larger than the assumed drive cycle time (in this case, however, the error occurs right at the start of the recording). Sample 2: This error can occur if the calling task has real-time errors (e.g. the "Exceed Counter" of the task increments or the task has a lower priority, as is often the case, for example, with the PLC). In this case the error can also occur at any time during the recording. Sample 3: This error can occur more frequently if the real-time load on the computer is quite high (>50 %). Note: Refer also to the corresponding AX5000 drive error code F440.
0x810F	33039	POSITIONMONITORING (=> NC Runtime Error)	Position monitoring: Axis position is outside of the maximum allowed moving range. The axis has left the parameterized position range window, whereupon the recording was aborted and the NC axis was placed in the error state 0x810F (with standard NC error handling). The position range window acts symmetrically around the initial position of the axis (see also parameter description <i>Position Monitoring Window</i>). Typical error message in the logger: <i>"BodePlot: 'Position Monitoring' error 0x%x because the actual position %f is above the maximum limit %f of the allowed position range (StartPos=%f, Window=%f)"</i>
0x8110	33040	DRIVELIMITATIONDETECTE D	Driver limitations detected (current or velocity limitations) which causes a nonlinear behavior and invalid results of the bode plot. A bode plot recording requires an approximately linear transmission link. If the speed or current is limited in the drive unit, however, this non-linear behavior is detected and the bode plot recording is aborted. Reasons for these limitations can be: choosing too large an amplitude for the position, speed or torque interface, or an unsuitable choice of amplitude scaling mode (see also parameter description <i>Amplitude Scaling Mode, Base Amplitude, Signal Amplitude</i>).

			<p>Typical error message in the logger: <i>"BodePlot: Sequence aborted with error 0x%x because the current limit of the drive has been exceeded (%d times) which causes a nonlinear behavior and invalid results of the bode plot"</i></p>
0x8111	33041	LIFECOUNTERMONITORING (=> NC Runtime Error)	<p>Life counter monitoring (heartbeat): Lost of communication to GUI detected after watchdog timeout is elapsed.</p> <p>The graphical user interface from which the bode plot recording was started is no longer communicating with the bode plot driver in the expected rhythm (keyword: 'Life Counter'). Therefore the recording is terminated immediately and the NC axes are placed in the error state 0x8111 (with standard NC error handling). Possible reasons for this can be an operating interface crash or a major malfunction of the Windows context.</p> <p>Typical error message in the logger: <i>"BodePlot: Sequence aborted with GUI Life Counter error 0x%x because the WatchDog timeout of %f s elapsed (%s)"</i></p>
0x8112	33042	NCERR_BODEPLOT_WCSTATE	<p>WC state error (IO data working counter)</p> <p>IO working counter error (WC state), for example due to real-time errors, EtherCAT CRC errors or telegram failures, EtherCAT device not communicating (OP state), etc.</p>
0x8113-0x811F	33043-33055	RESERVED	Reserved area

6.2.12 Further Error Codes

Error(Hex)	Error(Dec)	Error Type	Description
0x8120	33056	Environment	Invalid configuration for Object (e.g. in System Manager).
0x8121	33057	Environment	Invalid environment for Object (e.g. TcCom-Object's Hierarchy or missing/faulty Objects).
0x8122	33058	Environment	Incompatible Driver or Object.
0x8124	33060	Function Block	Command execution does not terminate (e. g. MC_Reset does not signal DONE).
0x8130	33072	Communication	Invalid ObjectID of Communication Target.
0x8131	33073	Communication	Communication Target expects Call in different Context.
0x8132	33074	Communication	Invalid State of Communication Target.
0x8134	33076	Communication	Communication with Communication Target cannot be established.
0x813b	33083	Parameter	Transition Mode is invalid.
0x813c	33084	Parameter	BufferMode is invalid.
0x813d	33085	Function Block	Only one active Instance of Function Block per Group is allowed.
0x813e	33086	State	Command is not allowed in current group state.
0x813f	33087	Function Block	Slave cannot synchronize. The slave cannot reach the SlaveSyncPosition with the given dynamics.
0x8140	33088	Parameter	Invalid value for one or more of the dynamic parameters (Acceleration, Deceleration, Jerk).

Error(Hex)	Error(Dec)	Error Type	Description
0x8141	33089	Parameter	IdentInGroup is invalid.
0x8142	33090	Parameter	The number of axes in the group is incompatible with the axes convention.
0x8143	33091	Communication	Function Block or respective Command is not supported by Target.
0x8144	33092	State	Command queue full. Command queue is completely filled up and cannot accept additional commands until some commands are fully processed.
0x8145	33093	Function Block	Mapping of Cyclic Interface between NC and PLC is missing (e.g. AXIS_REF, AXES_GROUP_REF, ...).
0x8146	33094	Function Block	Invalid Velocity Value. The velocity was not set or the entered value is invalid
0x8147	33095	Parameter	Invalid Coordinate Dimension. The dimension of the set coordinate interpretation does not meet the requirements.
0x8148	33096	Function Block	Invalid Input Value.
0x8149	33097	Parameter	Unsupported Dynamics for selected Group Kernel.
0x814a	33098	Parameter	The programmed position dimension incompatible with the axes convention.
0x814b	33099	Function Block	Path buffer is invalid. E.g. because provided buffer has invalid address or is not big enough.
0x814c	33100	Function Block	Path does not contain any element.
0x814d	33101	Function Block	Provided Path buffer is too small to store more Path Elements.
0x814e	33102	Parameter	Dimension or at least one Value of Transition Parameters is invalid.
0x814f	33103	Function Block	Invalid or Incomplete Input Array.
0x8150	33104	Function Block	Path length is zero.
0x8151	33105	State	Command is not allowed in current axis state.
0x8152	33106	State	TwinCAT System is shutting down and cannot complete request.
0x8153	33107	Parameter	Configured axes convention and configured axes do not match.
0x8154	33108	Initialization	Invalid Number of ACS Axes. The number of ACS input axes does not match the number of ACS input axes expected by the kinematic transformation.
0x8155	33109	Initialization	Invalid Number of MCS Data. The number of MCS input data does not match the number expected by the kinematic transformation.
0x8156	33110	Initialization	Invalid Value Set for Kinematic Parameters. The numeric value set for the parameter does not reside within the respective definition range.
0x8158	33112	NC Programming	The Given ACS Values Cannot be Reached. The given ACS values result in an invalid machine configuration.
0x8159	33113	NC Programming	The Set Target Positions Cannot be Reached. The set target positions reside outside the admissible working space.

Error(Hex)	Error(Dec)	Error Type	Description
0x815d	33117	NC Programming	Discontinuity in ACS axes detected. Discontinuity in ACS axes detected.
0x8160	33120	NC Programming	Circle Specification in Path is invalid. The specification of a circle segment in the programmed interpolated path (e.g. via MC_MovePath) has an invalid or ambiguous description. Probably its center cannot be determined reliably.
0x8161	33121	NC Programming	Maximum stream lines reached. The maximum number of stream lines is limited. Please refer to function block documentation for details.
0x8163	33123	Function Block	Invalid First Segment. The corresponding element can only be analyzed with a well-defined start point.
0x8164	33124	Function Block	Invalid auxiliary point. The auxiliary point is not well-defined.
0x8166	33126	Function Block	Invalid parameter for GapControlMode. Invalid parameter for GapControlMode, most likely in combination with the group parameter GapControlDirection.
0x8167	33127	External	Group got unsupported Axis Event (e.g. State Change). Group got unsupported Axis Event (e.g. State Change e.g. triggered by a Single Axis Reset).
0x8168	33128	Parameter	Unsupported Compensation Type. The compensation type was either not set or is not supported by the addressed object.
0x8169	33129	Function Block	Master axis does not exist or cannot be used.
0x816a	33130	External	Invalid or Missing Tracking Transformation. This error occurs at MC_TrackConveyorBelt if at the CoordTransform input an invalid object ID is used or the object ID points to an object that is not supported as coordinate transformation.
0x816b	33131	Function Block	Position is not on Track. Either Track cannot be activated because Actual Position is not on Track, or Target Position is not on Active Track or TrackPart
0x816c	33132	Function Block	Axis does not have an activated track.
0x816d	33133	NC Programming	Invalid Compensation ObjectId. An Object with this ObjectId does not exist or it is not of the right type (has to be a compensation).
0x816e	33134	Monitoring	Axis is in error because axis was not in Target when InTargetAlarm Timer expired.
0x816f	33135	State	Coupling would cause a cyclic dependency of axis (e.g. via MC_GearInPos).
0x8170	33136	Function Block	Axis was not added to an axes group, the command is not valid.
0x817f	33151	State	Drive has invalid State.
0x8181	33153	Function Block	Parameter for gap control are invalid with the current configuration. Function block with gap control was issued to an axis that is not in a CA group
0x8182	33154	State	Software position limit violation. Software position limits of at least one axis have been or would have been violated by a command.
0x8183	33155	NC Programming	Target position is not reachable. There is no path available to the target position or target position is unreachable in general.

Error(Hex)	Error(Dec)	Error Type	Description
0x8185	33157	NC Programming	The mover or one of its relevant coordinates is busy. Either the whole mover or at least of its coordinates relevant to the command are busy.
0x8186	33158	NC Programming	A collision has occurred or would occur. Either a collision has occurred or would occur if the command was executed.
0x8187	33159	NC Programming	Invalid Track Specification.
0x8188	33160	NC Programming	Command not allowed in track state.
0x8189	33161	Function Block	Invalid Reference passed to Function Block. An invalid reference (or pointer) was used in a function block call. This can happen if a reference type is used before it was initialized.
0x818a	33162	NC Programming	Path is locked against modifications. The path was locked to further changes. However, it might be resettable.
0x8f38 - 0x8f50	36664 - 36688	Internal	Internal Error.
0x8f56	36694	Internal	Internal Error.
0x8f59	36697	Internal	Internal Error.
0x8f5c - 0x8f62	36700 - 36706	Internal	Internal Error.
0x8f65	36709	Internal	Internal Error.
0x8f68 - 0x8ffe	36712 - 36862	Internal	Internal Error.

More Information:
www.beckhoff.com

Beckhoff Automation GmbH & Co. KG
Hülshorstweg 20
33415 Verl
Germany
Phone: +49 5246 9630
info@beckhoff.com
www.beckhoff.com

